



PROJECT: \_\_\_\_\_  
 ITEM # \_\_\_\_\_ QTY: \_\_\_\_\_  
 MODEL # \_\_\_\_\_  
 AIA # \_\_\_\_\_ SIS # \_\_\_\_\_

# WORKTOP DRAWER REFRIGERATOR

## VWRD27HC-2

WORKTOP DRAWER REFRIGERATOR



### CABINET CONSTRUCTION

- Stainless Steel Exterior (galvanized back & bottom)
- Aluminum Interior
- 4" High, Foamed-In-Place Backsplash
- One Piece, Snap-In Magnetic Drawer Gaskets
- 6" Casters Two (2) With Brakes
- 8' Cord And Plug (see electrical data for details)

### FEATURES

- Full Electronic Control
- Stay-Open Drawer Feature For Easy Product Loading
- Low Profile Horizontal Drawer Handles
- Heavy-Duty Pan Supports Provided
- Drawers Accommodates 6" Deep Full Size Food Service Pans In Both Upper And Lower Drawers (pans not included)
- Telescoping Drawer Slides With Locking Mechanism

### REFRIGERATION

- Refrigeration System Uses R-290 Refrigerant To Comply With All Environmental Concerns
- Rear Mounted Refrigeration System
- Adaptive Defrost For Reduced Energy Consumption And More Consistent Product Temperatures
- Epoxy Coated Evaporator Coil
- Refrigerator Capable Of Maintaining Product Temperature 36°F To 38°F

- ▶ **3 Year Parts & Labor Warranty**  
**Plus An Additional 4 Year Compressor Warranty**
- ▶ **Exclusive 2 Year Warranty On Magnetic Door Gaskets**
- ▶ **Lifetime Warranty On Handles & Hinges (parts only)**



Please verify qualifying units by visiting:  
[www.energystar.gov/cfs](http://www.energystar.gov/cfs)

### OPTIONS & ACCESSORIES

- |                            |                              |   |
|----------------------------|------------------------------|---|
| • Stainless Steel Interior | • Cutting Board              | • Casters: 3", Roller Kit, Low Profile  |
| • Stainless Steel Back     | • Drawer Locks               | • Remote Models* (6" legs only)<br>(refrigerant must be specified at time of order, see note on back on page) |
| • Secure-Temp™ Technology  | • 6" Legs or 6" Seismic Legs |   |

3779 Champion Blvd, Winston-Salem, NC 27105

ph: (888) 845-9800 | fax: (800) 253-5168

Sales@VictoryRefrigeration.com | VictoryRefrigeration.com

Rev. 10/22/21 Printed in U.S.A.

APPROVAL: \_\_\_\_\_ DATE: \_\_\_\_\_

# VICTORY WORKTOP DRAWER REFRIGERATOR

## VWRD27HC-2

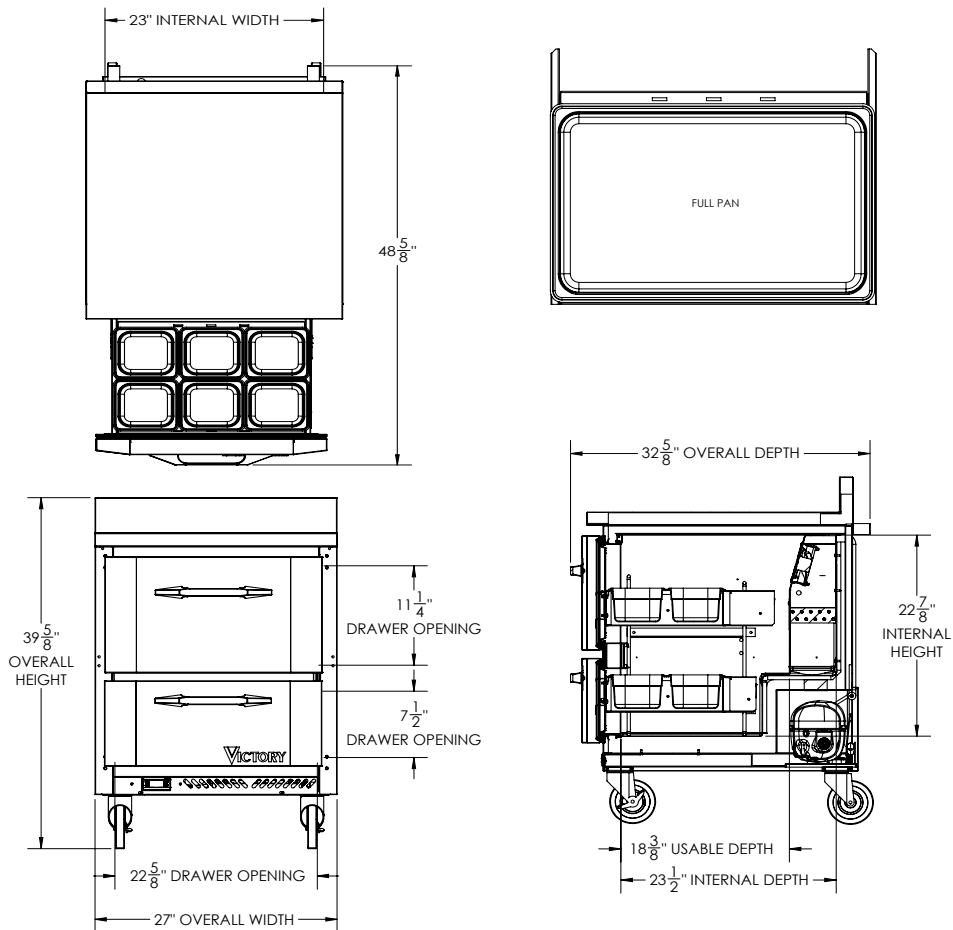

We reserve the right to change specifications and product design without notice. Such revisions do not entitle the buyer to corresponding changes, improvements, additions or replacements for previously purchased equipment. Dimensional tolerances +/- .14". Metric dimensions (MM)

CHARACTERISTICS		ELECTRICAL DATA		SHIPPING DETAILS	
Net Capacity (cubic ft.)	6.15	Cabinet Voltage	115/60/1	Height	49"
Width, Overall (in.)	27"	Total Amperes	2.0	Width	30"
Depth, Overall (with handle)	32 5/8"	NEMA Plug (8' cord)	5-15P	Depth	37"
Height Overall (6" casters)	39 5/8"	REFRIGERATION DATA		Crated Weight	232 lbs
Depth, Drawer Extended	48 5/8"	Condensing Unit Size, HP	1/10	*NOTE: Remote units are field wired and comes with 6" legs. Refrigerant must be specified at time of order.	
Drawer Opening (in.)	22 5/8" x 7 1/2" 22 5/8" x 11 1/4"	Refrigerant*	R-290		
No. Of Drawers	2	Capacity (BTU/HR) (100°F/20°F)	1110		
		Heat Rejection (BTU/HR)	1665		
		Charge (lbs/grams)	0.1323/60		

3779 Champion Blvd, Winston-Salem, NC 27105 | ph: (888) 845-9800 | fax: (800) 253-5168

Sales@VictoryRefrigeration.com | VictoryRefrigeration.com

Rev. 10/22/21 Printed in U.S.A.

an Ali Group Company



The Spirit of Excellence