



INVENTIVE SIMPLIFICATION

Project \_\_\_\_\_

Item \_\_\_\_\_

Quantity \_\_\_\_\_

Date \_\_\_\_\_

# XAVC-0511-EPL

XAVC-0511-EPL

## MODEL CHEFTOP MIND.Maps™ PLUS

- Combi steamer  
12 x 20 (Hotel Pans)

- Hinged Right  
(Left Hand Door)

- 5 Trays GN 1/1

- 9.5" Touch control panel

- Electric



### DESCRIPTION

Technologically advanced combination oven for gastronomy cooking processes (dehydrating, steaming, low temperature cooking, sous vide cooking, roasting, grilling, pan frying, regeneration and plated regeneration) and for fresh or frozen baking process thanks to **CLIMALUX™** technology that combines the production of high quality steam, **STEAM.Maxi™** with the controlled forced extraction of humidity **DRY.Maxi**.

Automatic management of cooking processes (**CHEFUNOX**) and assisted by **UNOX Intelligent Performance** artificial intelligence which guarantees perfect results and repeatability for any load size.

Best in class energy efficiency certified **ENERGY STAR**.

### KEY FEATURES

#### UNOX INTELLIGENT PERFORMANCE:

- **CLIMALUX:** Precise humidity control
- **SMART.Preheating:** Automatic and intelligent cooking chamber preheating
- **ADAPTIVE.Cooking:** Automatic adjustment of time, temperature and clima condition for a perfect result for any quantity of food
- **AUTO.Soft:** Automatic temperature rising management
- **SENSE.Klean:** Automatic and intelligent washing system based on actual oven use

#### DATA DRIVEN COOKING:

- **DDC Stats:** Oven usage and consumption reports
- **DDC App:** Remote analysis of usage and consumption

#### UNOX INTENSIVE COOKING:

- **STEAM.Maxi:** Humidity and steam production
- **DRY.Maxi:** Forced extraction of humidity
- **AIR.Maxi:** Multiple fans and auto-reversing fan speed
- **EFFICIENT.Power:** Triple glass insulation, Energy Star Certified

### STANDARD TECHNICAL FEATURES

- **ROTOR.Klean:** automatic washing system
- **Multipoint core probe:** 4 sensors
- Triple glass
- **USB data:** download/upload HACCP data
- **USB data:** download/upload programs
- Integrated Det&Rinse tank
- **LED** chamber illumination integrated in the door.
- **ENERGY STAR** certified
- Tray supports with anti-tipping system
- Stainless steel AISI 304 cooking chamber with retrofit washing

### STANDARD COOKING FEATURES

#### SETTINGS:

- **TEMPERATURE:** 86 °F - 500 °F
- **CLIMA.Control:** Humidity or dry air set by 10%.
- **FANS:** 4 fan speeds with auto-reverse and pulse function
- Up to 9 cooking steps
- Multipoint core probe
- Delta T cooking option
- **MIND.Maps™:** The new intuitive visual language setting to create your perfect cooking program

#### PROGRAMS:

- 1000+ programs
- **CHEFUNOX:** Automatic cooking programs
- **MULTITIME:** Up to 10 timers for multiple products cooking in the same environments
- **MISE EN PLACE:** Timed loading of up to 9 different items so they are all ready at the same time
- **READYCOOK:** Ready to use settings for a quick start
- **MIND.Maps™:** Up to 48 custom MIND.Maps™

#### UNOX INTENSIVE COOKING:

- **STEAM.Maxi:** Humidity and steam production
- **DRY.Maxi:** Forced extraction of humidity
- **AIR.Maxi:** Multiple fans and auto-reversing fan speed

### APP & WEB SERVICES

- Data Driven Cooking App and website
- Top Training smartphone app
- Combi guru smartphone app



We reserve the right to make technical improvements - March: 2018



INVENTIVE SIMPLIFICATION

# XAVC-0511-EPL

Views  
Connection positions  
Dimensions and Weights

XAVC-0511-EPL

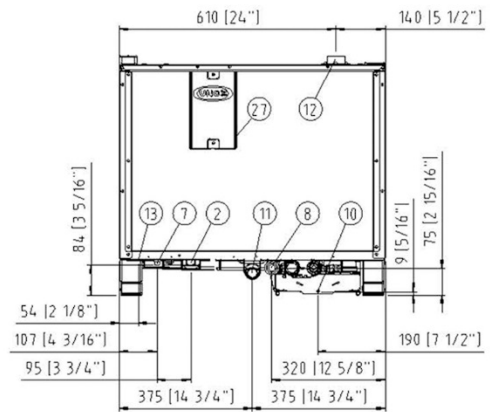
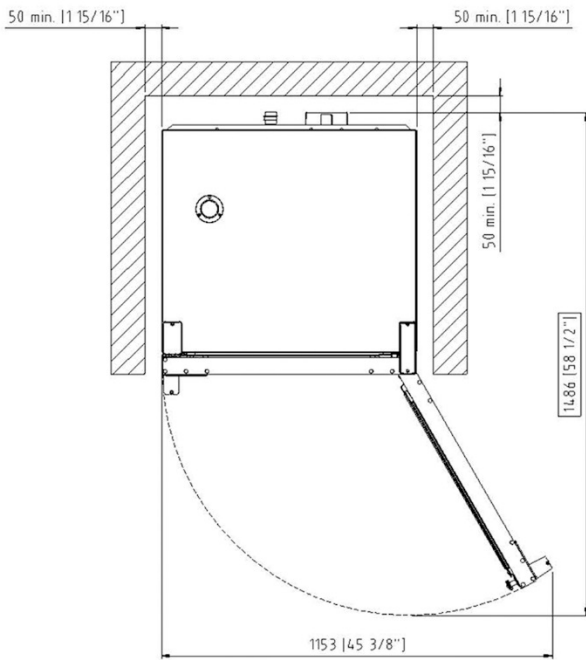
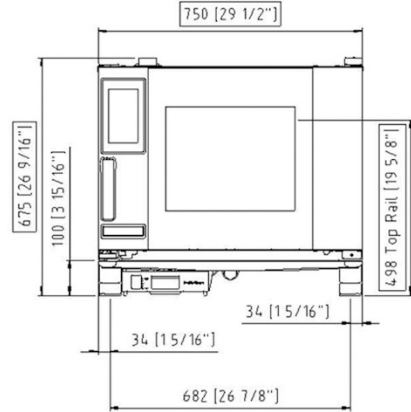
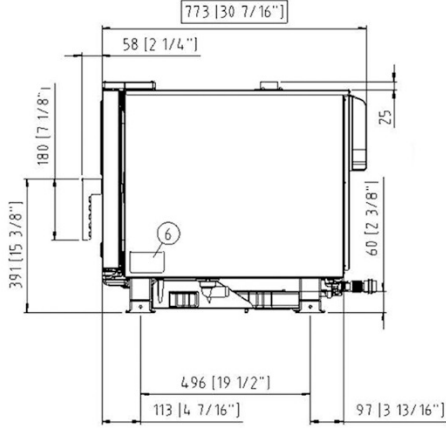

### DIMENSIONS AND WEIGHT

Width	29" 1/2 (750 mm)
Depth	30" 7/16 (773 mm)
Height	26" 9/16 (675 mm)
Net Weight	154.324 lbs (70 Kg)
Pan Spacing	2.63" (67 mm)

### CONNECTION POSITIONS

1	Terminal board cover box
2	Terminal board power supply
3	Unipotential terminal
6	Technical data plate
7	Safety thermostat
8	3/4" Thread water inlet
10	Rotor.KLEAN connection
11	Cavity drain pipe
12	Hot fumes exhaust chimney
13	Accessories connection
27	Cooling air outlet

We reserve the right to make technical improvements - March: 2018



INVENTIVE SIMPLIFICATION

# XAVC-0511-EPL

Power supply  
Water connections  
Installation requirements  
Accessories

XAVC-0511-EPL

## POWER SUPPLY

STANDARD	
Voltage	208-240 V
Phase	3PH+PE
Cycle	60 Hz
Total power	5.8 – 7.7 kW
Maximum Amp Draw	19 A
Required breaker size *	25 A
Power cable requirement	Cu 90°C 4 x AWG10
Cord diameter	0.63"
Plug	NOT INCLUDED

OPTION A	
Voltage	208-240 V
Phase	1PH+N+PE
Cycle	60 Hz
Total power	5.8 – 7.7 kW
Maximum Amp Draw	32 A
Required breaker size *	35 A
Power cable requirement	Cu 90°C 3 x AWG8
Cord diameter	0.63"
Plug	NOT INCLUDED
* Recommended size - observe local ordinances	

## INSTALLATION REQUIREMENTS

Installations must conform to all local electrical systems, specifically Minimum wire gauge required for field connection, hydraulic and ventilation codes.

## WATER CONNECTION

SUPPLY	
USING A WATER SUPPLY NOT MEETING UNOX's MINIMUM WATER QUALITY STANDARDS WILL VOID ANY WARRANTY.	
It is the responsibility of the purchaser to ensure that the incoming water supply is compliant with the specifications listed through adequate treatment measures.	
Line pressure:	Drinking water inlet: 3/4" NPT*, line pressure: 21 to 87 psi; 1.5 to 6 Bar
Connection	cold water

INFLOW WATER SPECIFICATIONS	
Free chlorine	≤ 0.1 ppm
Chloramine	0.1 ppm
TDS	≤ 125 ppm
Silica	≤ 12 ppm
pH	7 ÷ 8.5

STEAM CIRCUIT: INFLOW WATER SPECIFICATIONS	
Total hardness (TH)	≤ 8 °d
Chlorides	≤ 25 ppm
Alkalinity	≤ 150 ppm as CaCO3

## ACCESSORIES

- Det&Rinse PLUS:** Concentrated detergent and rinse aid
  - VENTLESS HOOD:** Steam condensing hood (water required)
  - COOKING ESSENTIALS:** Special trays
  - UNOX.FINEST**
  - UNOX.PURE**
  - Sous-vide** extra-fine core probe for sous-vide
  - Wi/Fi** connection board to keep the oven connected to UNOX cloud mandatory to extend warranty
  - HYPER.Smoker** Smoker box for wood chips and sawdust to smoke inside the cooking chamber without extra electrical supply
  - SMART.Drain** Special smart valve, that allows the fat collection from cooking process, to protect the drain from blocks
- Available in different voltage

Register to access data and product specifications  
[infonet.unox.com](http://infonet.unox.com)

