



Project \_\_\_\_\_  
 AIA # \_\_\_\_\_ SIS # \_\_\_\_\_  
 Item # \_\_\_\_\_ Quantity \_\_\_\_\_ C.S.I. Section 114000



TS SERIES - FULL SIZE PREP TABLE

## TS Series

Full Size Pizza/Salad/Sandwich Prep Tables  
 Self-Contained  
 48" One Door Models



(Shown with optional composite cutting board)

### STANDARD PRODUCT FEATURES

- "All-Day" Temperature Performance to NSF7 Test Requirements
- Stainless Steel Exterior & Interior
- Reliable Microprocessor Control With LED Temperature Display
- Self-Contained Refrigeration System Using R-450A Refrigerant
- Stainless Steel Insulated Lift-Up Rail Covers
- Accommodates Industry Standard Full, Half, Third, & 6" Deep Size Pans Without the Use of Adapter Bars (pans by others)
- Front-Breathing Design for "Zero-Clearance" Installation
- Non-Electric Automatic Condensate Evaporator
- Hot Gas Evaporator Defrost
- Metal Door Handle with Gasket Guard
- Magnetic Snap-In Door Gasket(s)
- Gasket-Protecting Stainless Steel Door Liner(s)
- Self-Closing Door with Stay-Open Feature
- Stainless Steel Field Rehingeable Door
- Standard Door Hinging: Right Hinging (other hinging available)
- Two (2) Shelves Per Door, On Shelf Pins (factory installed)
- 6" High Casters on Adjustable Channel System
- Thermostatic Expansion Valve Metering Device
- Large Interior Storage Capacity
- Side, Front & Rear Access Panel for Ease of Service & Maintenance
- Three (3) Year Parts and Labor Warranty
- Five (5) Year Compressor PartsWarranty



This unit is listed to the applicable UL, CSA and NSF Standards by an approved NRTL. Consult the factory or unit's data plate for approval information.

### AVAILABLE CONFIGURATIONS

48", 66", 72", & 90" Wide Models

Model	Model Type	Pan Capacity
TS048HT	48" 1-Solid Door Model	6 x 1/3 Pans

### ACCESSORIES & OPTIONS

- Stainless Steel Back
- Stainless Steel Shelves in Lieu of Standard Shelves
- Two (2) or Three (3) Drawers in Lieu of any Door
- Bi-Fold or Lift-Off Rail Covers
- Full Length White Plastic or Composite Cutting Board, 1/2"H x 18"D
- Set of 3" & 4" Casters or set of 6" Stainless Steel Legs
- Counter Top Garnish Rack
- Export 220/50/1 Voltage (consult factory)

Approved by \_\_\_\_\_ Date \_\_\_\_\_ Approved by \_\_\_\_\_ Date \_\_\_\_\_



# TS Series

Full Size Pizza/Salad/Sandwich Prep Tables  
Self-Contained

## MODELS

48" One Door Models: TS048HT

CLICK  
**TRANSFER**   
For KCL CADalog Website

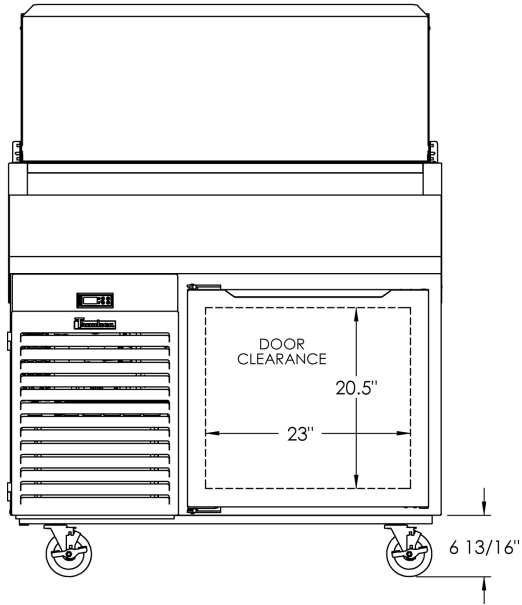

Elevation View

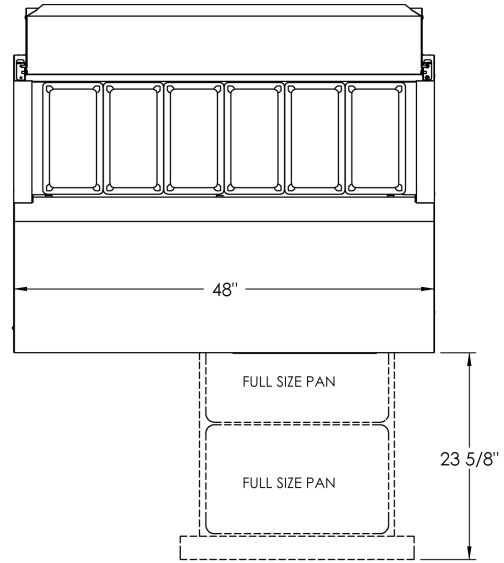

Top View

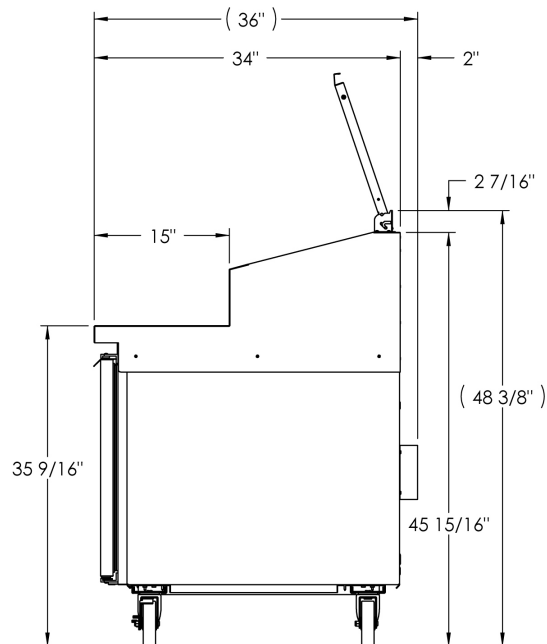

Section View



### MODELS

#### TS048HT

MODELS	TS048HT
<b>CABINET DIMENSIONAL DATA</b>	
Net Capacity cu. ft	9.5 (269 l)
# of Pans (third size)	6
Drawer Option Pan Configuration	Front to Back
Length - Overall in.	48 (121.9 cm)
Depth - Overall in <sup>1</sup>	36 (91.4 cm)
Clear Door Width in.	23 (58.4 cm)
Clear Door Height in.	20.5 (52.1 cm)
# of Doors	1
Standard Door Hinging	RH
# of Shelves	2
Shelf Area sq. ft. <sup>2</sup>	9.2 (.85 sq m)
Work Surface Height in.	35 9/16 (90.3 cm)
Height - Overall in.	48 3/8 (122.9 cm)
<b>ELECTRICAL DATA</b>	
Voltage	115/60/1
Plug	NEMA 5-15P
Full Load Amperes	7.2
MDEC <sup>3</sup>	N/A
<b>REFRIGERATION DATA</b>	
Refrigerant	R-450A
Refrigerant Amount oz.	17 (482 gr)
BTU/HR   HP <sup>4</sup>	4080   1/2 HP
<b>SHIPPING DATA</b>	
Length - Crated in.	66 (167.6 cm)
Width - Crated in.	42 (106.7 cm)
Height - Crated in.	56 (142.2 cm)
Volume - Crated cu. ft.	89.8 (2542.9 l)
Weight - Crated lbs.	509 (230.9 kg)

#### NOTES:

1. Depth - Overall includes 2" removal stand off bracket located on back of unit. See drawings for detailed dimensions.
2. Area of standard shelf compliment only, does not include storage area of additional shelves or area on cabinet bottom.
3. MDEC= Maximum Daily Energy Consumption
4. Based on a 90°F ambient and 20°F evaporator.

When ordering please specify: Voltage, Hinging, Options and any additional warranties.

This unit may be manufactured in other electrical characteristics and may have additional regulatory agency approvals. Consult factory for other electrical characteristics and agency approvals based on specific electrical and country requirements. For exact electrical information and approval marks, always refer to data label of the unit.

Equipped with one NEMA 5-15P Plug



### EQUIPMENT SPECIFICATIONS

#### CONSTRUCTION, HARDWARE, INSULATION

Unit exterior top and front sides are constructed of stainless steel, back and bottom is constructed of galvanized steel. Cabinet interior is constructed of stainless steel. Unit is insulated with an average 2" insulation on the top, bottom and all sides.

The 12" wide raised ingredient rail is designed to accommodate standard full, half or third size pans (pans supplied by others). Other size pans require use of adapter bars (pans and bars supplied by others). Accommodates 6" deep pans. Stainless steel insulated lift-up rail cover, with two convenient open positions. Doors are equipped with self-closing hinges and metal door handle with gasket guard.

#### INTERIOR

Standard interior arrangements include two (2) wire shelves per door, mounted on shelf pins. Recommended load limit per shelf should not exceed 225 lbs. Optional tray slides may be purchased in combination with, or in lieu of these. Both standard and optional interior arrangements are completely installed at the factory.

#### SELF-CONTAINED REFRIGERATION SYSTEM

The self-contained, balanced refrigeration system cools the cabinet interior, as well as the raised ingredient rail through use of an exclusive Temp Assure airflow ducting system which creates a layer of cold air over the pans, as well as all sides and bottom of the pans. This system distributes cold air from top to bottom, keeping the pans cold without freezing product and allows for "all-day" temperature performance to NSF7 test requirements. Environmentally friendly, non-flammable R-450A refrigerant is used in this system. The condensing unit features a hot gas evaporator defrost, thermostatic expansion valve, air-cooled hermetic compressor, plenum effect blower coil, large, high humidity evaporator coil located outside the food zone and a non-electric automatic condensate evaporator. A 9' cord and plug is provided. Standard operating temperature is 34° to 38°F.

#### CONTROL

The easy to use water resistant microprocessor control is supplied standard. It includes a 3-Digit LED Display, and a Fahrenheit or Celsius Temperature Scale Display Capability.

#### WARRANTY

Both a three year parts and labor warranty and a five year compressor warranty (self-contained models only) are provided standard.

CONTINUED PRODUCT DEVELOPMENT MAY NECESSITATE SPECIFICATION CHANGES WITHOUT NOTICE.