



Project _____
 AIA # _____ SIS # _____
 Item # _____ Quantity _____ C.S.I. Section 114000



DEALERS CHOICE G-SERIES

G-SERIES

1-Section Refrigerator Pass-Thru

Self-Contained Hinged Glass & Solid Door Combinations



(image may vary from actual product)

STANDARD PRODUCT FEATURES

- High Performance, Energy Efficient Refrigeration System
- Reliable Microprocessor Control With LED Temperature Display
- Evaporator Coil Outside Food Zone Provides More Usable Space
- Load-Sure Guard Prevents Problems From Improper Loading
- Durable All-Metal Construction
- Stainless Steel Front & Louver Panel, Triple Pane Glass Door & Stainless Steel Door, Anodized Aluminum Sides & Interior
- Full or Half Height Door Models with a Variety of Hinging Configurations
- Long Life EZ-Clean Door Gaskets
- Three (3) Epoxy Coated Shelves Per Section (factory installed)
- Easy to Maintain Front Facing Condenser Coil
- 6" High Locking Casters
- Guaranteed for Life Door Handles (Solid Door Only) & Hinges
- 3-Year Parts & Labor Warranty
- 2-Years Additional Compressor Parts Warranty



This unit is listed to the applicable UL, CSA and NSF Standards by an approved NRTL. Consult the factory or unit's data plate for approval information.

AVAILABLE CONFIGURATIONS

Model	Control Side Door Style/Hinging	Non Control Side Door Style/Hinging
G16002P	Solid Half/Right	Glass Half/Right
G16003P	Solid Half/Right	Glass Half/Left
G16004P	Solid Half/Left	Glass Half/Left
G16005P	Solid Half/Left	Glass Half/Right
G16012P	Solid Full/Right	Glass Full/Right
G16013P	Solid Full/Right	Glass Full/Left
G16014P	Solid Full/Left	Glass Full/Left
G16015P	Solid Full/Left	Glass Full/Right
G17002P	Glass Half/Right	Solid Half/Right
G17003P	Glass Half/Right	Solid Half/Left
G17004P	Glass Half/Left	Solid Half/Left
G17005P	Glass Half/Left	Solid Half/Right
G17012P	Glass Full/Right	Solid Full/Right
G17013P	Glass Full/Right	Solid Full/Left
G17014P	Glass Full/Left	Solid Full/Left
G17015P	Glass Full/Left	Solid Full/Right

ACCESSORIES & OPTIONS (*field installed)

- ▣ Tray Slides for 18" x 26" Sheet Pans*
- ▣ Tray Slides for 12" x 20" Food Pans*
- ▣ Tray Slides for 14" x 18" Sheet Pans*
- ▣ Tray Slides for 18" x 26, 12" x 20" & 14" x 18" Pans*
- ▣ Additional Shelves*
- ▣ 6" High Legs*
- ▣ Lower Height Casters*

*Please refer to form number TR35872 for precise kit details. See back page for tray slide versatility chart.

SECTION 4-28

Approved by _____ Date _____ Approved by _____ Date _____



CLICK
TRANSFER
 For KCL CADalog Website

MODELS

Half Height Door Models Solid & Glass Door Combinations:
 G16002P, G16003P, G16004P, G16005P

Half Height Door Models Glass & Solid Door Combinations:
 G17002P, G17003P, G17004P, G17005P

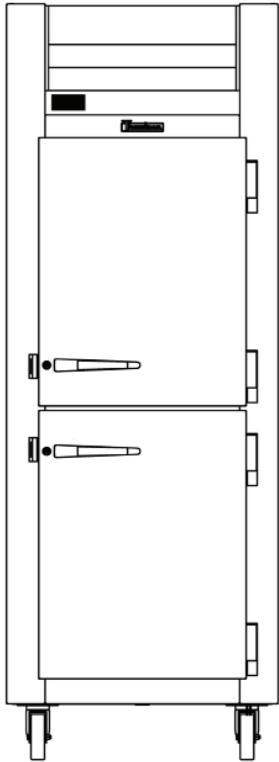

G16002P Control Side
 Solid Door
 Hinged Right Shown
 (other door combinations
 & hinging available)

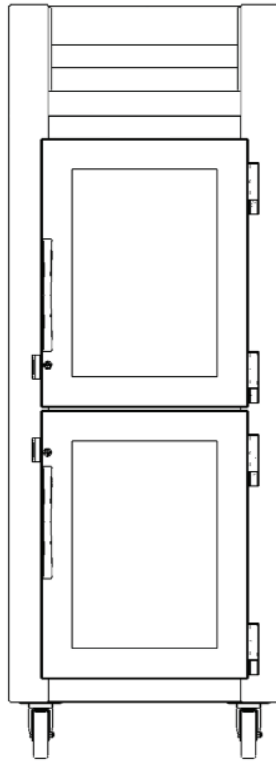

G16002P Non Control Side
 Glass Door
 Hinged Right Shown
 (other door combinations
 & hinging available)

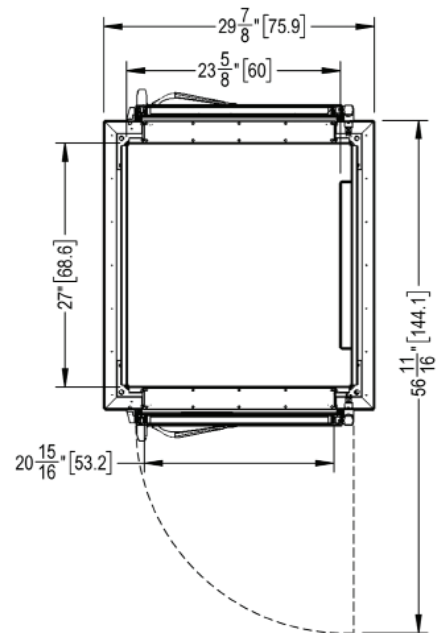
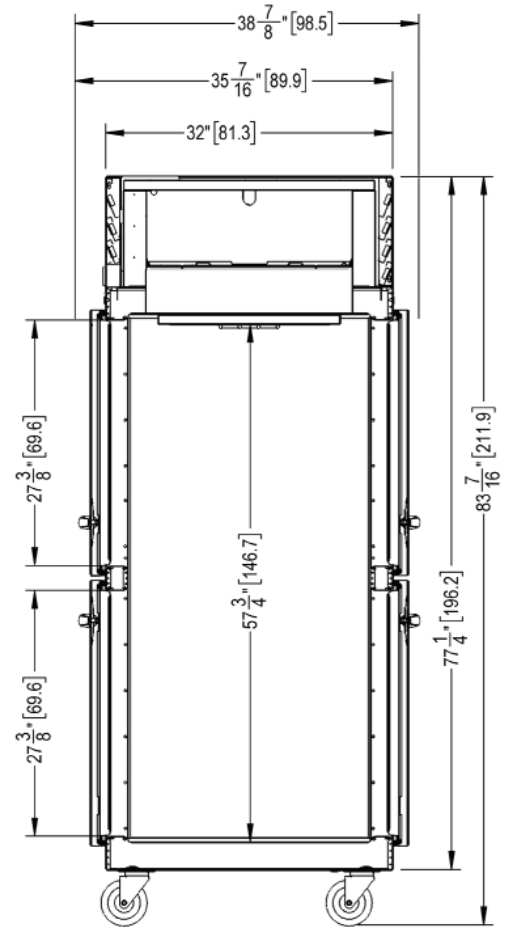

G-SERIES

1-Section Refrigerator Pass-Thru Self-Contained Hinged Glass & Solid Door(s)

CLICK
TRANSFER
For KCL CADalog Website

MODELS

Full Height Door Models Solid & Glass Door Combinations:
G16012P, G16013P, G16014P, G16015P

Full Height Door Models Glass & Solid Door Combinations:
G17012P, G17013P, G17014P, G17015P

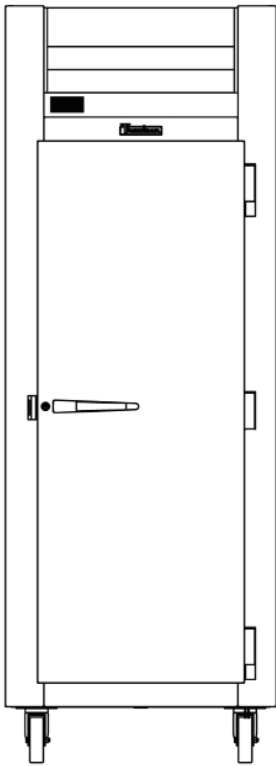

G16012P Control Side
Solid Door
Hinged Right Shown
(other door combinations
& hinging available)

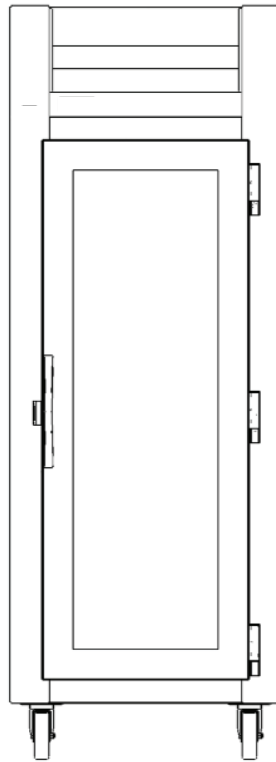

G16012P Non Control Side
Glass Door
Hinged Right Shown
(other door combinations
& hinging available)

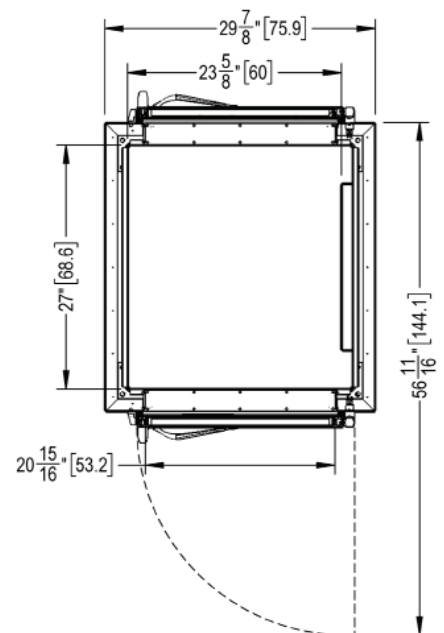
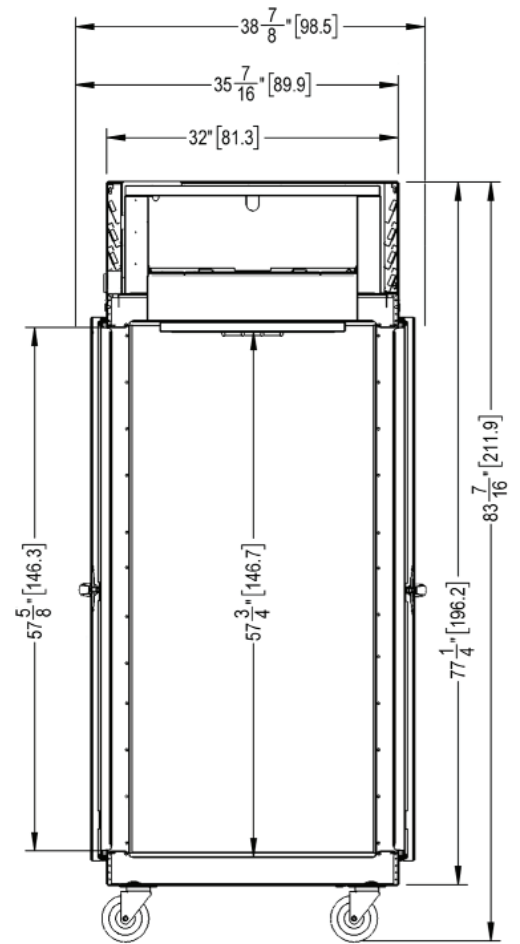



G-SERIES

1-Section Refrigerator Pass-Thru Self-Contained Hinged Glass & Solid Door Combinations

MODELS

Half Height Door Models Solid & Glass Door Combinations:

G16002P, G16003P, G16004P, G16005P

Half Height Door Models Glass & Solid Door Combinations:

G17002P, G17003P, G17004P, G17005P

Full Height Door Models Solid & Glass Door Combinations:

G16012P, G16013P, G16014P, G16015P

Full Height Door Models Glass & Solid Door Combinations:

G17012P, G17013P, G17014P, G17015P

EQUIPMENT SPECIFICATIONS

CONSTRUCTION, HARDWARE, INSULATION

Cabinet exterior front, louver assembly and doors are constructed of stainless steel. Cabinet sides (including returns), interior and door liners are constructed of anodized aluminum. The exterior cabinet top and bottom are constructed of heavy gauge galvanized steel. A set of four (4) 6" (15 cm) high casters are included.

Doors are equipped with removable plug cylinder locks and guaranteed for life cam-lift, gravity action, self-closing metal, glide hinges with stay open feature at 120°. An external switch is provided to activate the interior LED lighting.

Gasket profile and durable long life material simplify cleaning and increase overall gasket life. Anti-condensate heaters are located behind each door opening.

The cabinet is insulated with an average of 2" (5 cm) thick high density, non-CFC, foamed in place polyurethane.

SELF-CONTAINED REFRIGERATION SYSTEM

A top mounted, self-contained, refrigeration system using environmentally friendly, non-flammable R-450A refrigerant is conveniently located behind the one piece louver assembly. It features an easy to clean front facing condenser, thermostatic expansion valve, air-cooled hermetic compressor, large, high humidity evaporator coil located outside the food zone and a top mounted non-electric condensate evaporator. A 9' (2.7 m) NEMA cord and 15-5P plug is provided. Standard operating temperature is 34° to 38°F (1° to 3°C)

CONTROL

The easy to use water resistant microprocessor control system is supplied standard. It includes a 3-Digit LED Display with both a Fahrenheit or Celsius Temperature Scale Display Capability

INTERIOR ARRANGEMENTS

Standard interior arrangements include three (3) epoxy coated wire shelves per section, mounted on shelf pins, installed at the factory. Shelves are full-width, and do not have any large gaps between them requiring the use of "bridge" or "junior shelves." Recommended load limit per shelf should not exceed 225 lbs. (102kg).

DOMESTIC WARRANTY

Both a three year parts and labor warranty and a five year compressor warranty (self-contained models only) are provided standard.

NOTES:

1. Net Capacity cu. ft. = Half Height Door | Full Height Door models.
2. Height shown when mounted on standard 6" high casters.
3. Figure shown reflects the area of standard shelf complement.
4. MDEC = Maximum Daily Energy Consumption
5. Based on a 90°F ambient and 20°F evaporator.

MODELS	G160__P & G170__P
DIMENSIONAL DATA	
Net Capacity cu. ft. ¹	25.03 (708.8 l) 25.29 (716.1 l)
L x D x H - Overall in. ²	29 ⁷ / ₁₆ (75.9 cm) x 37 ⁵ / ₁₆ (96.4 cm) x 83 ⁷ / ₁₆ (211.9 cm)
Depth - over body in.	32 (81.3 cm)
Depth - door open 90° in.	83 ³ / ₈ (211.8 cm)
Clear half-door W x H in.	21 ¹ / ₈ (53.6 cm) x 27 ¹ / ₂ (69.9 cm)
Clear full-door W X H in.	21 ¹ / ₈ (53.6 cm) x 57 ³ / ₈ (146.3 cm)
No. Standard Shelves	3
Shelf Area sq. ft. ³	18.8 (1.75 sq m)
ELECTRICAL DATA	
Voltage Plug	115/60/1 NEMA 5-15P (attached)
Feed wires with ground	3
Full Load Amperes MDEC ⁴	6.1 3.22 KWH/Day
REFRIGERATION DATA	
Refrigerant	R-450A
Refrigerant Charge Amount	16 oz
BTU/HR H.P. ⁵	2240 1/2 HP
Required Clearance	12" Above
SHIPPING DATA	
L x D x H Crated in.	48 (122 cm) x 42 (107 cm) x 85 (216 cm)
Volume Crated cu. ft.	99 (2803 l)
Uncrated Crated Weight lbs.	320 (145 kg) 365 (166 kg)

OPTIONAL ACCESSORY TRAY SLIDE VERSATILITY CHART

TRAY SLIDE DRAWINGS						
TRAY SLIDE OFFERING	#1 (1) 18" x26" or (2) 14"x18"	#4 (Rod Type) (1) 18" x26"	Universal (1) 18" x26" or (2) 14"x18" or (2) 12"x20"	#1 EZ-Change (1) 18" x26" or (2) 14"x18"	Universal EZ-Change (1) 18" x26" or (2) 14"x18" or (2) 12"x20"	HD Universal EZ-Change (1) 18" x26" or (2) 14"x18" or (2) 12"x20"
SPACING CAPACITY DOOR SIZE	2" 28 Pairs Full Door & 13 Half 3" 19 Pairs Full Door & 09 Half 4" 14 Pairs Full Door & 07 Half 5" 11 Pairs Full Door & 05 Half	1 1/2" 38 Pairs Full Door (2 Pair) 1 1/2" 18 Pairs Half Door (1 Pair)	4" 14 Pairs Full Door & 06 Half ¹ 4" 14 Pairs Full Door & 07 Half ² 5" 11 Pairs Full Door & 05 Half 6" 09 Pairs Full Door & 04 Half	2" 26 Pairs Full Door & 12 Half 4" 13 Pairs Full Door & 06 Half	2 1/4" 22 Pairs Full Door & 11 Half 4 1/2" 11 Pairs Full Door & 05 Half	4 1/2" 11 Pairs Full Door & 05 Half 9" 05 Pairs Full Door & 02 Half

- Upper Half Height Door¹
- Lower Half Height Door²

CONTINUED PRODUCT DEVELOPMENT MAY NECESSITATE SPECIFICATION CHANGES WITHOUT NOTICE.