

Project	Quantity	Item #
Model Specified:		CSI Section 11400

### "N-Width" Pass-Thru Refrigerator Models/ Self-Contained



Model Shown Two Section  
(shown with optional casters)

### One, Two & Three Section Models, 32" Deep



Stainless Exterior  
& Interior

1-Section Full Length Door Model	RHT132NPUT-FHS
2-Section Full Length Door Model	RHT232NPUT-FHS
3-Section Full Length Door Model	RHT332NPUT-FHS
1-Section Half Length Door Model	RHT132NPUT-HHS
2-Section Half Length Door Model	RHT232NPUT-HHS
3-Section Half Length Door Model	RHT332NPUT-HHS



Stainless Exterior,  
Anodized Alumi-  
num Interior

1-Section Full Length Door Model	AHT132NPUT-FHS
2-Section Full Length Door Model	AHT232NPUT-FHS
3-Section Full Length Door Model	AHT332NPUT-FHS
1-Section Half Length Door Model	AHT132NPUT-HHS
2-Section Half Length Door Model	AHT232NPUT-HHS
3-Section Half Length Door Model	AHT332NPUT-HHS

The "N-Width" pass-thru refrigerator models are all designed to offer maximum interior storage capacity within a slightly narrower left to right footprint. Each is supplied standard with such high quality features as balanced refrigeration systems, microprocessor controls, and stainless steel exteriors. Additionally, they offer the widest range of optional accessories to choose from, and can be specified for use with many different applications, including: Foodservice, Correctional, Institutional, Export, etc.

### Standard Product Features

- Traulsen's Smart Control With LED Display
- StayClear™ Condenser
- R-Series: Stainless Steel Exterior & Interior
- A-Series: Stainless Steel Exterior/Anodized Aluminum Interior
- Balanced, Self-Contained Refrigeration System Using R-450A
- Rear Biased Return Air Duct
- Full or Half Length Stainless Steel Doors With Locks
- Self-Closing Doors With Stay Open Feature At 120°F
- Guaranteed For Life Cam-Lift Hinges
- Guaranteed For Life Horizontal Work Flow Door Handles
- Standard Door Hinging F & R: 132NP = Left\Right, 232NP = Left/Right, 332NP = Left/Right/Right (other hingings available)
- Automatically Activated LED Lights
- Stainless Steel Breaker Caps
- Three Adjustable Wire Shelves Per Section, Supported On Shelf Pins (installed at the factory)
- Automatic Non-Electric Condensate Evaporator
- Magnetic Snap-In EZ-Clean Door Gasket(s)
- Gasket-Protecting Metal Door Liner
- Thermostatic Expansion Valve Metering Device
- Stainless Steel One-Piece Louver Assembly
- 9' Cord & Plug Attached
- Set of Four (4) 6" High Adjustable Stainless Steel Legs
- Three Year Parts And Labor Warranty
- Five Year Compressor Warranty

### Options & Accessories

- No. 1 Type Tray Slides To Accommodate either (1) 18" x 26" or (2) 14" x 18" Pans
- No. 4 Type Tray Slides To Accommodate (1) 18" x 26" Sheet Pans (rod type, equips 1/2 section)
- Universal Type Tray Slides (contact factory)
- Additional Wire Shelves or Optional Stainless Steel Shelves
- EZ-Change Interiors (#1, universals, universal heavy duty tray slides and shelves)
- EZ-Open Foot Pedal (full height doors only)
- Locking Hasps (padlocks supplied by others)
- Optional 220/50/1 or 208/115/60/1 Voltages
- Kool Klad Exterior Laminate Decor
- Set of Four (4) 4-5/8" or 6" High Casters In Lieu of Legs
- Other Support Options: 4-1/2" High Base or 6" High Kickplate
- Remote Applications (see form TR35837 for more details)<sup>3</sup>
- Remote For Use With 20°F Glycol System
- Clear Glass Door(s) In Place Of One Or More Solid Door(s)



Listed by Underwriters Laboratories Inc., to U.S. and Canadian safety standards and Listed by NSF International.



Approval: \_\_\_\_\_

Project	Quantity	Item #
Model Specified:		CSI Section 11400

## Specifications

### Construction, Hardware and Insulation

Cabinet exterior front, one piece sides, louver assembly and doors are constructed of 20 gauge stainless steel with #4 finish. Cabinet interior and door liners are constructed of stainless steel (anodized aluminum in the A-Series). The exterior cabinet top and bottom are constructed of heavy gauge galvanized steel. A set of four (4) adjustable 6" high stainless steel legs are included.

Doors are equipped with a gasket protecting metal door pan, removable plug cylinder locks and guaranteed for life cam-lift, gravity action, self-closing metal, glide hinges with stay open feature at 120°F. Hinges include a concealed switch to automatically activate the interior LED lighting. Guaranteed for life, work flow door handles are mounted horizontally over recess in door which limits protrusion from door face into aiseways. Doors have seamless, polished metal corners.

Gasket profile and Santoprene® material simplify cleaning and increase overall gasket life. Anti-condensate heaters are located behind each door opening.

Both the cabinet and door(s) are insulated with an average of 2" thick high density, non-CFC, foamed in place polyurethane.

DIMENSIONAL DATA	R/AHT132NPWT	R/AHT232NPWT	R/AHT332NPWT
Net capacity cu. ft.	21.2 (600.3 cu l)	48.3 (1368 cu l)	73.1 (2071 cu l)
Length - overall in.	26 <sup>3</sup> / <sub>16</sub> (66.9 cm)	52 <sup>1</sup> / <sub>2</sub> (132.4 cm)	76 <sup>5</sup> / <sub>16</sub> (193.8 cm)
Depth - overall in.	37 <sup>15</sup> / <sub>16</sub> (96.4 cm)	37 <sup>15</sup> / <sub>16</sub> (96.4 cm)	37 <sup>15</sup> / <sub>16</sub> (96.4 cm)
Depth - over body in.	32 (81.3 cm)	32 (81.3 cm)	32 (81.3 cm)
Depth - doors open 90° in.	91 <sup>3</sup> / <sub>16</sub> (206.7 cm)	79 <sup>1</sup> / <sub>2</sub> (201.9 cm)	79 <sup>1</sup> / <sub>2</sub> (201.9 cm)
Clear door width in.	21 <sup>1</sup> / <sub>8</sub> (53.6 cm)	21 <sup>1</sup> / <sub>8</sub> (53.6 cm)	21 <sup>1</sup> / <sub>8</sub> (53.6 cm)
Clear half-door height in.	27 <sup>1</sup> / <sub>2</sub> (69.9 cm)	27 <sup>1</sup> / <sub>2</sub> (69.9 cm)	27 <sup>1</sup> / <sub>2</sub> (69.9 cm)
Clear full-door height in.	57 <sup>5</sup> / <sub>16</sub> (146.3 cm)	57 <sup>5</sup> / <sub>16</sub> (146.3 cm)	57 <sup>5</sup> / <sub>16</sub> (146.3 cm)
Height - overall on 6" legs <sup>4</sup>	83 <sup>3</sup> / <sub>4</sub> (211.5 cm)	83 <sup>3</sup> / <sub>4</sub> (211.5 cm)	83 <sup>3</sup> / <sub>4</sub> (211.5 cm)
RHT Net Wt. lbs.	640 (290 kg)	640 (290 kg)	890 (404 kg)
AHT Net Wt. lbs.	565 (256 kg)	565 (256 kg)	790 (358 kg)
No. Standard Shelves	3	6	9
Shelf area sq. ft. <sup>1</sup>	17.3 (1.60 sq m)	34.6 (3.21 sq m)	51.9 (4.82 sq m)
<b>ELECTRICAL DATA</b>			
Voltage	115/60/1	115/60/1	115/60/1
Feed wires with Ground	3	3	3
Full load amperes	7.2	8.6	12.0
<b>REFRIGERATION DATA</b>			
Refrigerant	R-450A	R-450A	R-450A
Refrigerant Charge Amount	14 oz	27 oz	30 oz
BTU/HR H.P. <sup>2</sup>	2240 (1/3 HP)	4610 (5/8 HP)	4900 (3/4 HP)

### NOTES

- NOTE: Figures in parentheses reflect metric equivalents.
- Area of standard shelf compliment only, does not include storage area of additional shelves or available on cabinet bottom.
  - Based on a 90°F ambient and 20°F evaporator.
  - For approximate remote weights deduct 40 lbs. from respective net or gross weight. For other information on remote models, please refer to form TR35837.
  - 12" Top clearance preferred for optimum performance and service access.



### Equipped With One NEMA 5-15 P Plug

NOTE: Full load amps and plug style may vary depending on electrical options chosen and condensing unit employed.

### Refrigeration System

A top mounted, self-contained, balanced refrigeration system using environmentally friendly, non-flammable R-450A refrigerant is conveniently located behind the one piece louver assembly. It features a finless StayClear™ condenser, thermostatic expansion valve, air-cooled hermetic compressor, large, high humidity evaporator coil located outside the food zone and a top mounted non-electric condensate evaporator. Biased return air duct protects against introduction of warm kitchen air, promoting even temperature maintenance and efficient operation. A 9' cord and plug is provided. Standard operating temperature is 34 to 38°F.

### Controller

Traulsen's Smart Control features advanced control algorithms and sophisticated diagnostic capabilities. Smart sensors will adapt the operation of the refrigeration system to a variety of environments and usage patterns. The Smart Control offers a complete set of visual alarms designed to alert the user to critical events. In the event of an alarm, a dedicated Alarm LED will illuminate, informing the user of the critical event and describing the event in the large, easy to read full text display.

### Interior

Standard interior arrangements include three (3) coated wire shelves per section, mounted on shelf pins. Shelves are full-width, and do not have any large gaps between them requiring the use of "bridge" or "junior shelves". Recommended load limit per shelf should not exceed 225 lbs. Optional tray slides may be purchased in combination with, or in lieu of these. Interior arrangements are installed at the factory and EZ-Change interior slides (only) are field installed.

### Warranties

Both a three year parts and labor warranty and a five year compressor warranty (self-contained models only) are provided standard.

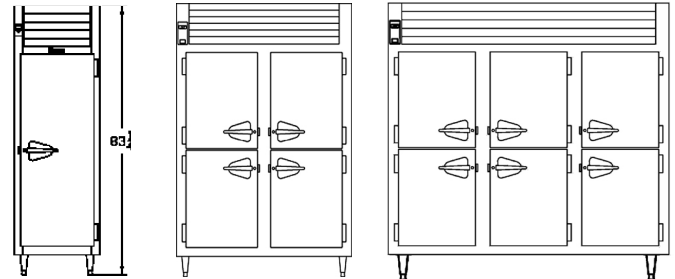
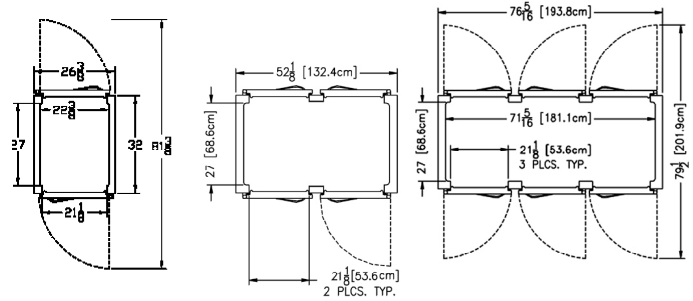

Section - All Models

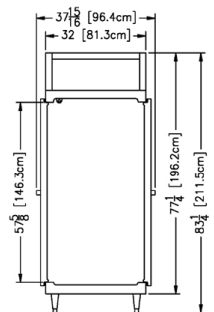

NOTE: When ordering please specify: Voltage, Hinging, Door Size, Options and any additional warranties.

Continued product development may necessitate specification changes without notice.

Part No. TR35760 (REV. 01-21-19)

TRAULSEN  
4401 BLUE MOUND RD.  
PHONE 1 (800) 825-8220  
Website: www.traulsen.com

FT. WORTH, TX 76106  
FAX-MKTG. 1 (817) 624-4302

