

Project	Quantity	Item #
Model Specified:		CSI Section 11400

Reach-In/Pass-Thru Refrigerated-Heated Models/Self-Contained



Model Shown One Section
(shown with optional casters)



Stainless Exterior
& Interior

Half Length Door Reach-In Model RDH132WUT-HHS
Half Length Door Pass-Thru Model RDH132WPUT-HHS



Stainless Exterior,
Anodized Aluminum Interior

Half Length Door Reach-In Model ADH132WUT-HHS
Half Length Door Pass-Thru Model ADH132WPUT-HHS

The reach-in and pass-thru refrigerated/heated models are all designed to offer maximum interior storage capacity. Each is supplied standard with such high quality features as balanced refrigeration systems, microprocessor controls, and stainless steel exteriors. Additionally, they offer the widest range of optional accessories to choose from, and can be specified for use with many different applications, including: Foodservice, Correctional, Institutional, Export, etc.

Standard Product Features

- Traulsen's Smart Control With LED Display
- R-Series: Stainless Steel Exterior & Interior
- A-Series: Stainless Steel Exterior/Anodized Aluminum Interior
- Balanced, Self-Contained Refrigeration System Using R-450A
- Half Length Stainless Steel Doors With Locks
- Self-Closing Doors With Stay Open Feature At 120°F
- Guaranteed For Life Cam-Lift Hinges
- Guaranteed For Life Horizontal Work Flow Door Handle
- Standard Door Hinging: 132W = Right, F & R: 132WP = Right (other hings available)
- Automatically Activated LED Lights
- Stainless Steel Breaker Caps
- Adjustable Wire Shelves (installed at the factory)
- Magnetic Snap-In EZ-Clean Door Gasket(s)
- Gasket-Protecting Metal Door Liner
- Stainless Steel One-Piece Louver Assembly & Heater Guards
- 9' Cord & Plug Attached
- Set of Four (4) 6" High Adjustable Stainless Steel Legs
- Three Year Parts And Labor Warranty
- Five Year Compressor Warranty

Options & Accessories

- Stainless Steel Finished Back With Rear Louvers (reach-in models only)
- Re-Hinging Feature For Door(s)
- No. 1 Type Tray Slides To Accommodate either (1) 18" x 26" or (2) 14" x 18" Sheet Pans, Adjustable To 2" O.C.
- Universal Type Tray Slides To Accommodate Either (1) 18" x 26" or (2) 14" x 18" Sheet Pans, or (2) 12" x 20" Steam Table Pans, Adjustable To 4" O.C.
- Additional Wire Shelves
- EZ-Change Interiors (#1, universals, universal heavy duty tray slides and shelves)
- Locking Hasps (padlocks supplied by others)
- Export 220/50/1 Voltage
- Stainless Steel Shelves
- Kool Klad Exterior Laminate Decor
- Set of Four (4) 6" High Casters In Lieu of Legs
- Set of Four (4) 4-5/8" High Casters In Lieu of Legs
- 4-1/2" High Stainless Steel Base In Lieu of Legs
- 6" High Stainless Steel Kickplate (for use with standard legs)
- Prison/Correctional Facilities Options
- Remote Applications (see spec sheet TR35837 for details)
- Clear Glass Door(s) In Place Of One Or More Door(s)



Approval: _____



TRAULSEN
 4401 BLUE MOUND RD.
 PHONE 1 (800) 825-8220
 Website: www.traulsen.com

FT. WORTH, TX 76106
 FAX-MKTG. 1 (817) 624-4302

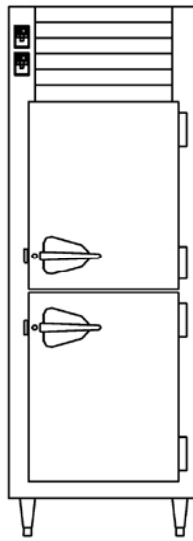

Elevation - R/ADH132WUT

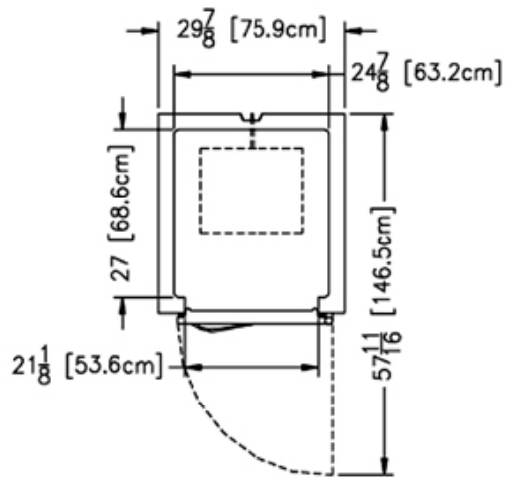

Plan - R/ADH132WUT

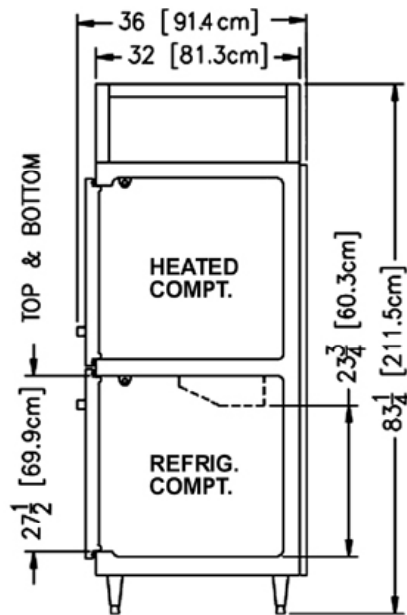

Section - R/ADH132WUT

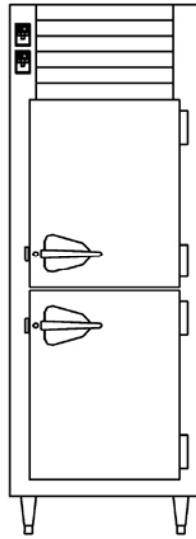

Elevation - R/ADH132WPUT

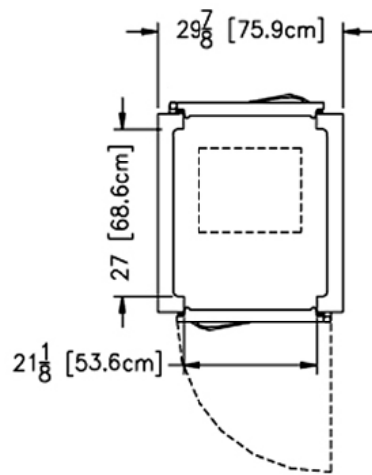

Plan - R/ADT132WPUT

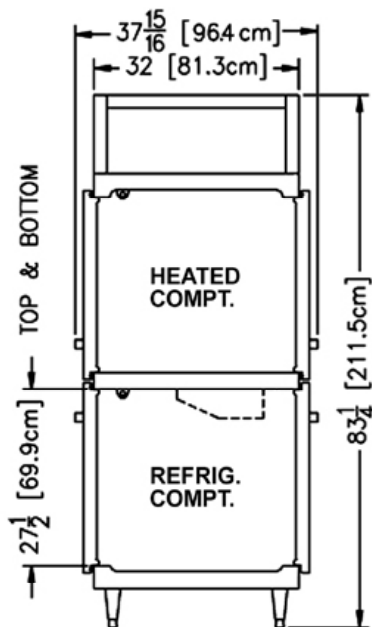

Section - R/ADH132WPUT



TRAULSEN
 4401 BLUE MOUND RD.
 PHONE 1 (800) 825-8220
 Website: www.traulsen.com

FT. WORTH, TX 76106
 FAX-MKTG. 1 (817) 624-4302

Project	Quantity	Item #
Model Specified:		CSI Section 11400

Specifications

Construction, Hardware and Insulation

Cabinet exterior front, one piece sides, louver assembly and doors are constructed of 22 gauge stainless steel with #4 finish. Cabinet interior and door liners are constructed of stainless steel (anodized aluminum in the A-Series). The exterior cabinet top, and bottom are constructed of heavy gauge galvanized steel. The exterior cabinet back on reach-in models is constructed of heavy gauge aluminized steel. A set of four (4) adjustable 6" high stainless steel legs are included.

Doors are equipped with a gasket protecting metal door pan, removable plug cylinder locks and guaranteed for life cam-lift, gravity action, self-closing metal, glide hinges with stay open feature at 120°F. Hinges include a concealed switch to automatically activate the interior LED lighting. Guaranteed for life, work flow door handles are mounted horizontally over recess in door which limits protrusion from door face into aiseways. Doors have seamless, polished metal corners.

Gasket profile and material simplify cleaning and increase overall gasket life. Anti-condensate heaters are located behind each door opening.

Both the cabinet and doors are insulated with an average of 2" thick high density, non-CFC, foamed in place polyurethane.

DIMENSIONAL DATA	R/ADH132WUT	R/ADH132WPUP
Cabinet Type	Reach-In	Pass-Thru
Net capacity total cu. ft.	20.6 (584 cu l)	20.6 (584 cu l)
Length - overall in.	29 ⁷ / ₈ (75.9 cm)	29 ⁷ / ₈ (75.9 cm)
Depth - overall in.	35 (88.8 cm)	37 ¹⁵ / ₁₆ (96.4 cm)
Depth - over body in.	32 (81.3 cm)	32 (81.3 cm)
Depth - door(s) open 90° in.	57 ¹¹ / ₁₆ (146.5 cm)	83 ³ / ₄ (211.8 cm)
Clear door width in.	21 ¹ / ₈ (53.6 cm)	21 ¹ / ₈ (53.6 cm)
Clear half-door height in.	27 ¹ / ₂ (69.9 cm)	27 ¹ / ₂ (69.9 cm)
Height - overall on 6" legs ⁴	83 ³ / ₄ (211.5 cm)	83 ³ / ₄ (211.5 cm)
No. Standard Shelves	2	2
Shelf area total sq. ft. ¹	28.0 (2.6 sq m)	28.0 (2.6 sq m)
Shelf area refrigerator. sq. ft. ¹	14.0 (1.3 sq m)	14.0 (1.3 sq m)
Shelf area heated section sq. ft. ¹	14.0 (1.3 sq m)	14.0 (1.3 sq m)
RDH Net Wt. lbs. ³	380 (172 kg)	405 (184 kg)
ADH Net Wt. lbs. ³	330 (150 kg)	355 (161 kg)
ELECTRICAL DATA		
Voltage	208/115/60/1	208/115/60/1
Feed wires with Ground	4	4
Wattage @ 208V	1500	1500
Full load amperes	11.0	11.0
REFRIGERATION DATA		
Refrigerant	R-450A	R-450A
Refrigerant Charge Amount	11 oz	11 oz
BTU/HR H.P. ²	2220 (1/3 HP)	2220 (1/3 HP)

NOTES

NOTE: Figures in parentheses reflect metric equivalents.

- 1= Area of standard shelf complement only, does not include storage area of additional shelves or available on cabinet bottom.
 2= Based on a 90°F ambient and 20°F evaporator.
 3= For approximate remote weights deduct 40 lbs. from respective net or gross weight. For other information on remote models, please refer to spec sheet TR35837.
 4= 12" Top clearance preferred for optimum performance and service access.

Refrigeration System

A top mounted, self-contained, balanced refrigeration system using environmentally friendly, non-flammable R-450A refrigerant is conveniently located behind the one piece louver assembly. These models feature an easy to clean front facing condenser, thermostatic expansion valve, air cooled hermetic compressor, large, high humidity evaporator coil. Biased return air duct protects against introduction of warm kitchen air, promoting even temperature maintenance and efficient operation.

A 9' cord and plug is provided standard. Standard operating temperatures are 34 to 38°F for the refrigerator compartment and 135 to 180°F for the heated compartment.

Heating System

A low watt density, serpentine style, heater is employed for the generation of electric heat. Low velocity air is forced across its large surface area to efficiently move heat radiating away from these through a down-air distribution duct, where it is then evenly distributed throughout the cabinet, assuring the proper holding environment for hot food product, without drying. A vent, located at the top of the cabinet, is included for positive humidity control.

Controller

Traulsen's Smart Control features advanced control algorithms and sophisticated diagnostic capabilities. Smart sensors will adapt the operation of the refrigeration system to a variety of environments and usage patterns. The Smart Control offers a complete set of visual alarms designed to alert the user to critical events. In the event of an alarm, a dedicated Alarm LED will illuminate, informing the user of the critical event and describing the event in the large, easy to read full text display.

Interior

Standard interior arrangements include two (2) wire shelves per section, mounted on pilasters. Shelves are full-width, and do not have any large gaps between them requiring the use of "bridge" or "junior shelves". Recommended load limit per shelf should not exceed 225 lbs. Optional tray slides may be purchased in combination with, or in lieu of these. Interior arrangements are installed at the factory and EZ-Change interior slides (only) are field installed.

Warranties

Both a three year parts and labor warranty and a five year compressor warranty (self-contained models only) are provided standard.



AW-03118

Listed by Underwriters Laboratories Inc., and classified by Underwriters Laboratories Inc., in accordance with ANSI/NSF7.



**One Section Models
Equipped With One NEMA L14-20P Plug**

NOTE: Full load amps and plug style may vary depending on electrical options chosen and condensing unit employed.

NOTE: When ordering please specify: Voltage, Hinging, Door Size, Options and any additional warranties.

Continued product development may necessitate specification changes without notice.

Part No. TR35784 (REV. 04-15-19)

TRAUlsen
 4401 BLUE MOUND RD.
 PHONE 1 (800) 825-8220
 Website: www.traulsen.com

FT. WORTH, TX 76106
 FAX-MKTG. 1 (817) 624-4302

