

Standard Features

Models:

HDG-24V HDG-36V HDG-48V HDG-60V

- 30,000 BTU (NAT) burner per 12"
- Electronic spark ignition (battery)
- Stainless steel front, vent and sides are standard, rear and bottom panels are aluminized steel.
- Reinforced, insulated double wall sides
- 1" thick polished rolled steel plate
- 5" high rear and 4" side splash guards
- 3/4" rear gas connection and pressure regulator
- Protected flue opening
- Exclusive "NO COLD" Zone - Uniform heat distribution across surface
- Each burner equipped with runner tube
- Two grease basins with large capacity (16 quarts each)
- Fully welded griddle plate with protected exhaust vent
- "Insta-on" thermostatic controls for precise settings between 200°F and 400°F
- Imbedded load sensing thermostat
- Flame failure safety device
- Stainless steel front towel bar



Model shown HDG-48V

Job
#

STANDARD CONSTRUCTION SPECIFICATIONS

Exterior Finish: Front, sides and vent are constructed of #3 polished 430 and 304 stainless steel. Bottom and rear are aluminized steel. Sides are reinforced and fully insulated. 5" rear and 4" side splash.

Griddle Plate: 48" wide unit, 30,000 BTU (NAT) per 12" burner. Fully welded, 1" thick polished steel griddle plate with side splash guards.

Basin: Second grease basin provided as spare for quick change. (Excluding model HDG-24V)

Griddle Controls: Independent, "Insta-on" thermostatic controls with uniform temperature range of 200°F to 400°F. (Thermostatic models ONLY)

Casters: 4" casters for stand.

Gas Heat Control System: Each foot of griddle is heated by a "U" shaped burner. Each burner is controlled by a thermostatic control. For safety, each pilot has a flame failure device. A 3/4" rear gas connection is standard.



Models: HDG-24V HDG-36V HDG-48V HDG-60V

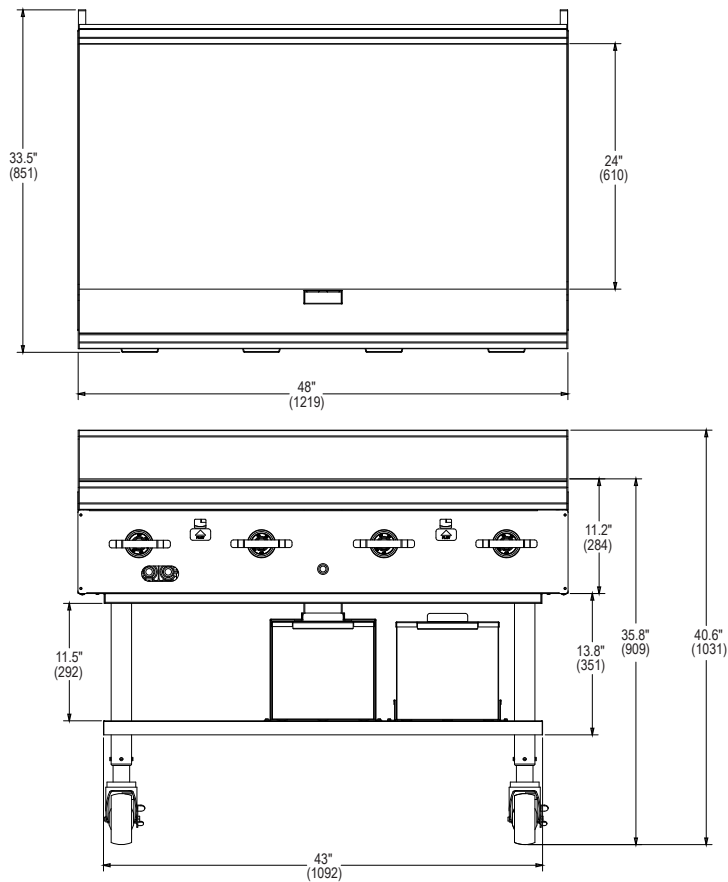

SHIPPING CRATE DIMENSIONS & WEIGHT					
MODEL	WIDTH	NUMBER OF BURNERS	CRATED WIDTH	CRATED DEPTH	CRATED WEIGHT
HDG-24V	24" (610)	2	58" (1474)	30" (762)	335 lb (152 kg)
HDG-36V	36" (915)	3	58" (1474)	45" (1143)	490 lb (222 kg)
HDG-48V	48" (1220)	4	58" (1474)	45" (1143)	600 lb (272 kg)
HDG-60V	60" (1525)	5	69" (1753)	48" (1220)	780 lb (353 kg)

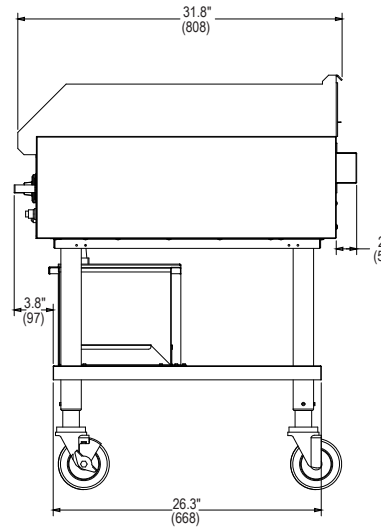

UTILITY INFORMATION

GAS: Each unit has a 3/4" rear gas connection with a male NPT connector (female when regulator is added). Minimum supply pressure is 7" W.C. for natural gas. All units require a regulated gas supply pressure regulator included. If using a flexible hose gas connection, the I.D. of the hose must not be smaller than the connector on the unit and must comply with ANSI Z21.69, providing an adequate means of restraint to prevent undue strain on the gas connection.

MODEL	GAS (BTU/HR)
	NATURAL
HDG-24V	60,000
HDG-36V	90,000
HDG-48V	120,000
HDG-60V	150,000

MISCELLANEOUS

- With casters using flex hose, a restraining device should be used to eliminate undue strain on the flex hose.
- Minimum clearance from noncombustible construction is zero. Minimum clearance from combustible construction is 12" on sides and 8" on rear.
- Install under vented hood.
- Check local codes for fire and sanitary regulations.

NOTICE: Southbend has a policy of continuous product research and improvement. We reserve the right to change specifications and product design without notice. Such revisions do not entitle the buyer to corresponding changes, improvements, additions or replacements for previously purchased equipment.

**INTENDED FOR COMMERCIAL USE ONLY.
NOT FOR HOUSEHOLD USE.**



1100 Old Honeycutt Road, Fuquay-Varina, NC 27526
(919) 762-1000 www.southbendnc.com