



CONVECTION OVEN

B-SERIES ALL TERRAIN GAS, SINGLE DECK

Standard Features

BGS/12SCAT

- 54,000 BTU (LP)
- Standard depth
- Single deck convection oven is 55-1/4" in height
- Patented "plug-in, plug-out" control panel - easy to service
- Slide out control panel for full view servicing
- Stainless steel front, sides and top
- Full stainless steel dependent doors (Full 180° opening)
- Transportation door locks (Pad lock not included)
- Fully enclosed stainless steel rear jacket for transportation protection
- Heat keeping dual door seal system
- Top and bottom rear covers for utility protection
- Coved, porcelain interior
- Stay cool heavy duty door handle
- Soft Air, two-speed, 1/2 hp fan motor
- Custom design rugged terrain tube chassis
- Integrated equipment shelf on tube chassis
- 11-position rack guides and 5 plated oven racks
- Electronic ignition
- Forced cool down fan mode
- Oven "heat" light cycles with burners
- All Terrain 10" casters
(1000 lbs maximum capacity)
- Interior oven lights
- (1) year limited parts and labor warranty
(reference <http://www.southbendnc.com/service.html> for limited warranty details)



BGS/12SCAT All Terrain

Available Control

SC-Standard Controls

140°F to 500°F solid state thermostat and 60 minute mechanical cook timer.

STANDARD CONSTRUCTION SPECIFICATIONS

Exterior Finish: Stainless steel front, sides and top.

Doors: Dependent doors, stainless steel construction, heavy-duty welded steel frame and 5/8" diameter full-length hinge pin.

Oven Interior: Porcelain enamel finish, coved, fastener free.

Rack and Rack Guides: Heavy-duty removable wire rack guides spaced on 1-5/8" centers offer 11 different rack positions. 5 wire racks provided with each oven.

Blower Fan and Motor: 1/2hp, 2-speed motor, 1710/1120 r.p.m

Oven Heating: 54,000 BTU (LP). Oven heating is regulated

by an adjustable thermostat control. Blower fan circulates air within the cavity "scrubbing" heat to the oven interior for even heat distribution within the cavity.

Electronic Ignition: Hot surface ignitor with flame safety device.

Control Panel: Located on front, at right side of oven, away from heat zone. Slide out panel extends over 17" for easy servicing.

Interior Lights: Two 40 watt high temperature recessed lamps located within the oven cavity.

Casters: All Terrain 10" pneumatic casters (1000 lbs maximum capacity)



Job _____
Item# _____

Models: **BGS/12SCAT**

Dimensions -in (mm)

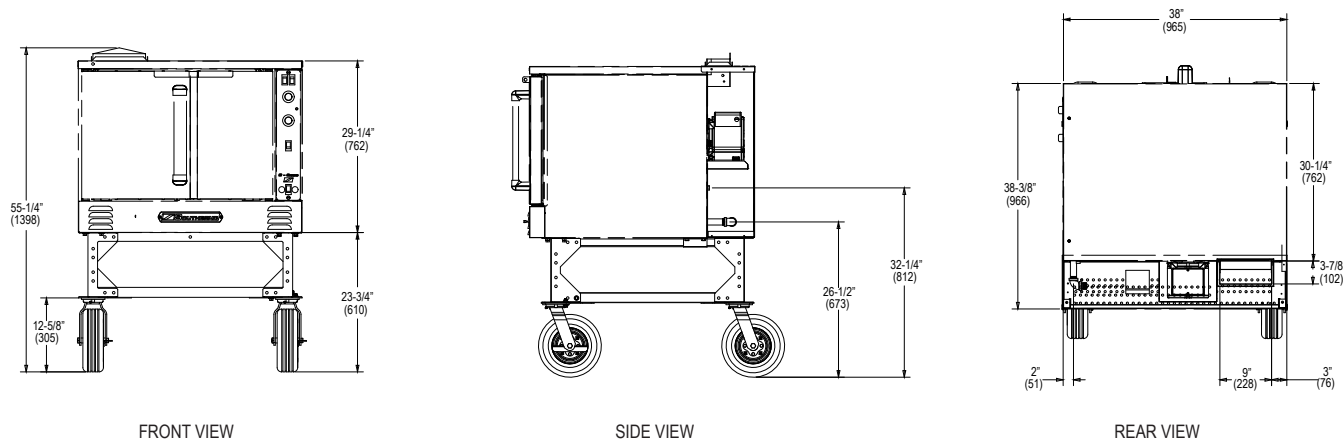

MODEL	DEPTH			OVEN INTERIOR			RACK CLEARANCE		SHIPPING CRATE				
	A	B	C	WIDTH	DEPTH	HEIGHT	WIDTH	DEPTH	WIDTH	DEPTH	HEIGHT	VOLUME	WEIGHT
BGS/12SCAT	37.25" (946)	30.25" (768)	33.75" (857)	29" (737)	21.50" (546)	20" (508)	28.25" (718)	21" (533)	57.50" (1461)	45.5" (1156)	81.5" (2070)	123.4 cu. ft. (3.49 cu. m.)	750 lbs (340 kg.)

Note: When shipped on legs, crated height is 69" (1753 mm)

UTILITY INFORMATION

GAS:

- 54 ,000 BTU (LP)
- One 3/4" male connection
- Required minimum inlet pressure:
- Propane gas 11" W.C.

ELECTRIC: Standard: 120/60/1 phase, furnished with 6' cord w/3-prong plug (1 plug/deck). NEMA #5-15p. Total maximum amps 7.9.

* All units are shipped single phase.

MISCELLANEOUS

- If using flex hose connector, the I.D should not be smaller than 3/4" and must comply with ANSI Z 21.69.
- If casters are used with flex hose, a restraining device should be used to eliminate undue strain on the flex hose.
- Clearances from combustibles: Top-0", bottom-0", right side-0" and left-2"
- Recommend - Install under vented hood if operated indoors
- Check local codes for fire and sanitary regulations
- If the unit is connected directly to the outside flue, an CSA approved down draft diverter must be installed at the flue outlet of the oven
- Oven cannot be operated without fan in operation

Notice: Southbend reserves the right to change specifications and product design without notice. Such revisions do not entitle the buyer to corresponding changes, improvements, additions, or replacements for previously purchased equipment.

OPTIONS AND ACCESSORIES

- 3/4" quick disconnect with flexible hose (specify length: 3ft, 4ft, or 5ft)flue
- Down draft diverter for direct flue
- Chassis mount dry chemical fire extinguisher (Class A,B & C) 5 lbs capacity

**INTENDED FOR COMMERCIAL USE ONLY.
NOT FOR HOUSEHOLD USE.**



1100 Old Honeycutt Road, Fuquay-Varina, NC 27526
(919) 762-1000 www.southbendnc.com