



DROP-IN

HOT FOOD WELL WITH AUTO-WATER FILL MODEL 9560AWF

Stainless steel drop-in, electrically heated hot food well unit with individually thermostatically controlled wells. Separate control panel for field installation, prewired. Unit supplied with individual drains, manifolded to common gate valve with auto-water fill system.

PROJECT NAME:

LOCATION:

ITEM NO:

QTY:

MODEL NO:

AIA NO:

SIS NO:

CSI SECTION: 11400

AVAILABLE MODELS:

- 9560-1AWF
- 9560-2AWF
- 9560-3AWF
- 9560-4AWF
- 9560-5AWF
- 9560-6AWF

STANDARD FEATURES:

- Individual drains, manifolded to common gate valve and supplied with auto-water fill connection
- True thermostatic control for precise food temperatures
- Approved for installation in either stainless or laminate counter work
- Units listed under N.S.F. standard 4
- UL approved

UNIT TOP: Top to be one piece 18 gauge stainless steel. Top openings to be die-stamped with raised perimeter rims.

FOOD WELLS: Units fitted with compliment of 12" x 20" x 6 1/2" deep, electrically heated, sealed food wells, individually thermostatically controlled. Unit prewired to controls, mounted on separate stainless steel panel.

UNIT BODY: Fully insulated exterior body of corrosion resistant steel.

CONTROLS: Controls prewired to junction box mounted on separate stainless steel panel for field installation in counter front. Connections to heating elements to be located outside of heated zone to avoid wiring deterioration. 208 or 240V operation. (120V available on request).

ORIGIN OF MANUFACTURE: Designed and manufactured in the United States.

9560AWF series drop-in Hot Food Well, Model 9560-4AWF shown.

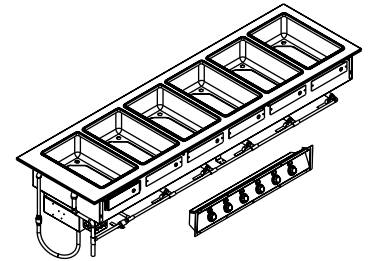

OPTIONS/ACCESSORIES:

- Adaptor bars
- Extended thermostatic lead

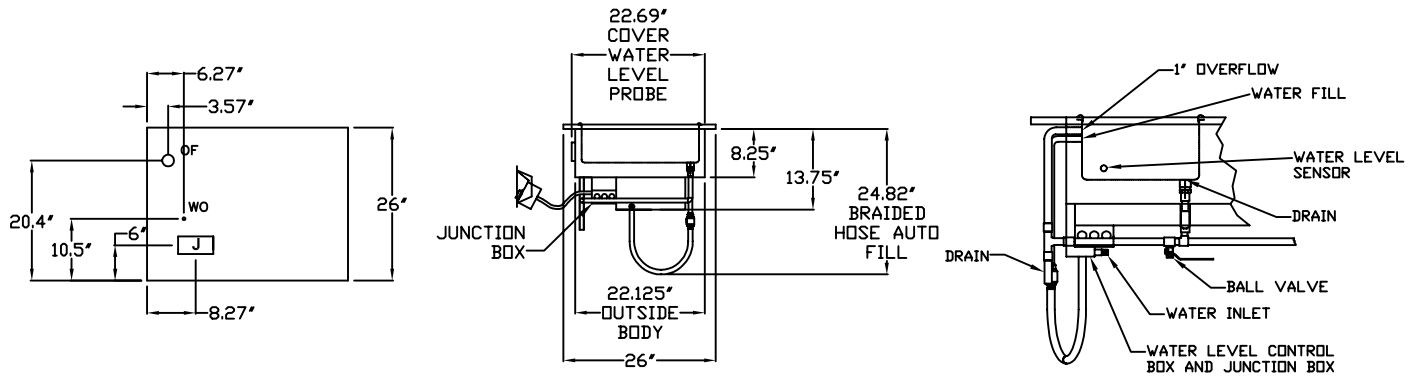
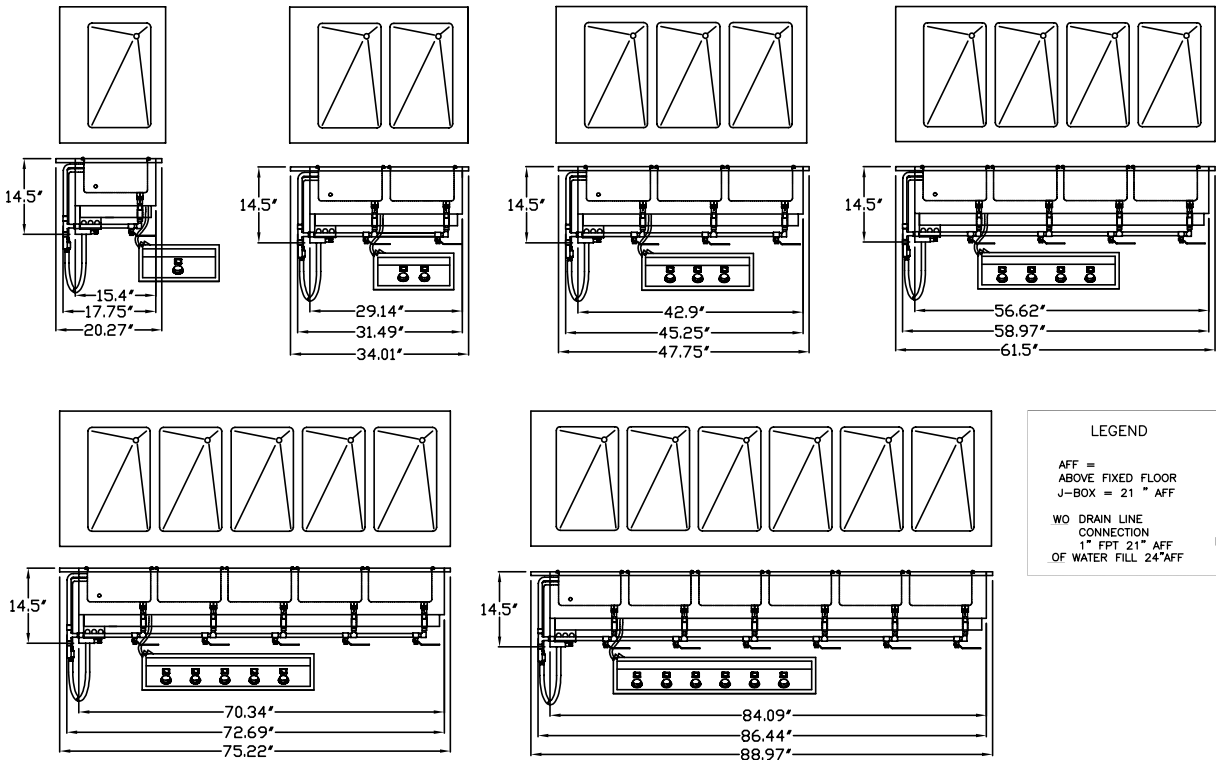

Model	Length	Depth	12"x20" Pan Cap.	Cut Out Size		No. of Elements	Watts	Amps/ 60/1 PH			Ship Wt.
				Unit	Control panel			120V	208V	240V	
9560-1AWF	20.27"	26"	1	18 1/4 x 23 3/16"	14 1/4"x 6"	1	1100	9.2	5.3	4.6	60
9560-2AWF	34.01"	26"	2	32 x 23 3/16"	14 3/8"x 6"	2	2200	18.4	10.6	9.2	85
9560-3AWF	47.75"	26"	3	45 3/4" x 23 3/16"	20 1/4"x 6"	3	3300	27.6	15.9	13.8	103
9560-4AWF	61.5"	26"	4	59 1/2" x 23 3/16"	26 1/4"x 6"	4	4400	36.8	21.2	18.4	170
9560-5AWF	75.22"	26"	5	73 3/16" x 23 3/16"	32 1/8"x 6"	5	5500	46	27.5	23	230
9560-6AWF	88.97"	26"	6	86 7/8" x 23 3/16"	38"x 6"	6	6600	55.2	31.7	27.6	290