



Specification

SelfCookingCenter® SCC XS E (4 x 13 x 18 inch) UltraVent Plus XS



Capacity

- Three (3) GN 2/3 (1 1/2") or GN 2/3 (2 1/2 ") or four (4) 1/2 size sheet pans
- Removable, swivel hinging rack with flexible rack options on 7 levels

Standard Features

- Electrically heated table device for automatic cooking of meat, poultry, fish, side dishes, vegetables, egg dishes, desserts, bakery products and for automatic rethermalization
- Mixed loads with individual supervision of each rack, depending on type, load amount, and the number of door openings
- LED cooking cabinet and rack lighting - energy-saving, durable and low-maintenance
- Unit base with surrounding seal
- Rear-ventilated triple-pane cooking cabinet door, two hinged inside panes (for easy cleaning) with a special heat-reflecting coating
- Combi-steamer according to DIN 18866, DIN 10535 for selective use of steam and hot air, separately, sequentially, or combined
- Integrated Ethernet and USB port to connect to a cloud based system for administration of cooking processes, management of HACCP and service data and remote control
- Lengthwise loading for 2/3, 1/2, 1/3 GN (12" x 14", 12" x 10", 12" x 7") accessories, 1/2 size sheet pans and steam pans
- No water softening system or additional descaling is necessary
- 2-Year parts and labor warranty
- 5-Year steam generator warranty
- No-charge 4-hour RATIONAL certified chef assistance program
- Core temperature probe with 6 measuring points, including positioning aid - automatic error correction in case of incorrect positioning
- 1% - accurate regulation of moisture, adjustable, and retrievable via the control panel
- Combi-steamer mode °F/(°C): steam: 85 to 265/(30 to 130), hot air: 85 to 575/(30 to 300), combination: 85 to 575/(30 to 300)
- Individual programming of at least 1,200 cooking programs with up to 12 steps transferable via USB
- Hand shower with automatic retracting system
- Moisturising in 3 steps of °F/(°C) 85 to 500/(30 to 260)
- High-performance fresh steam generator, pressureless, with automatic filling and automatic decalcification
- Dynamic air circulation in cooking cabinet with reversing wheel fan with 5 fan speeds, programmable

- Integral, maintenance-free grease extraction system
- Turbo fan cool down function
- Automatic adaptation to the installation location (elevation)
- 304 (DIN 1.4301) stainless steel material inside and out
- Seamless interior and with rounded corners
- Demand-related energy supply
- 5 programmable proofing stages
- Automatic, pre-selected starting time with adjustable date/time
- Delta-T cooking
- Factory installed UltraVent Plus with 2 speed fan motor. The condensation technology in the UltraVent captures and dissipates steam in the form of condensate. The UltraVent Plus is equipped with special filters, which prevents both vapours and the lingering smoke that builds up while grilling and roasting. Units can be installed even in critical locations, such as front shop-front areas. There is no need for a connection to the outside.
- UL listed as Commercial Cooking Appliance with Integral Systems for Limiting the Emission of Grease-laden Air

Operation

- Digital, graphically supported overview of the current cooking chamber climate, review and forecast as well as repeat and change options at the end of the cooking process
- Remote control function for appliance using software and mobile app
- Control second unit from the main unit (units must be connected via ethernet or network)
- Real-time information about automatic adjustments on current cooking process
- Self-learning operation, automatically adapts to actual usage
- Intelligent energy-management system controls the energy and airflow, fully automated
- Record mode – determination of the ideal cooking process for calibrated products using the core temperature probe for subsequent use without a core temperature probe, with automatic consideration of the load quantity
- Self-configurable, user-specific operating display 8.5" TFT color monitor and touch screen with self-explanatory symbols for ease of operation
- Application and user manuals can be viewed on the unit display for the current actions

Safety features

- Detergent and Care Tabs (solid detergents) for optimum working safety
- HACCP data output and software update via the integrated Ethernet and USB port
- Safety temperature limiter for steam generator and hot-air heating
- VDE approved for unsupervised operation (e.g. overnight cooking or cleaning)
- Maximum rack height 5 1/4 ft./1.60 m when original stand is used
- Integral fan impeller brake
- Door handle with right/left and slam function

Cleaning and Care

- Self-cleaning and care system for cooking cabinet and steam generator, regardless of the water pressure supplied
- 7 cleaning stages for unsupervised cleaning and care - even overnight
- Automatic cleaning and descaling of the steam generator
- Automatic cleaning prompts indicating the cleaning stage and volume of chemicals in relation to the level of soiling
- Soiling and care status are displayed on the monitor
- Diagnostic system with automatic service notices displayed
- Self-test function for actively checking unit's functions
- 100% biodegradable Cleaner and Care tabs

Ventilation approvals

- This appliance conforms to the EPA 202 test in accordance to the ANSI/NFPA 96 "Ventilation Control and Fire Protection of Commercial Cooking Operations" Refer to UL Listing KNLZ.E148536 (America) or KNLZ7.E148536 (Canada).

Approval/Labels





Specification

SelfCookingCenter® SCC XS E (4 x 13 x 18 inch) UltraVent Plus XS

ConnectedCooking



For proper usage of ConnectedCooking a network socket according to RJ45 has to be provided. For optimal performance a cable-bound connection with a data rate of at least 10 Mb/s is the preferred connection. Alternatively W-LAN connections with appropriate W-LAN adaptors can be used.

Combi-Steam mode



Steam °F/(°C) 85 to 265/(30 to 130)



Hot air °F/(°C) 85 to 575/(30 to 300)



Combi °F/(°C) 85 to 575/(30 to 300)

iCookingControl - Automatic cooking



7 application modes for meat, poultry, fish, side dishes, egg dishes, desserts, baked goods and Finishing® (rethermalization)

HiDensityControl®



Highest steam saturation, and dynamic air mixing for perfect and even cooking

Efficient CareControl



Efficient self-cleaning CareControl recognizes soiling and scale and removes it

iLevelControl



Mixed loads with individual monitoring of every rack depending on the quantity of the load as well as the number of door openings.

Technical Specification

Dimensions	Width	Depth	Height
Exterior	25 7/8" (657 mm)	22 1/2" (566 mm)	35 3/8" (897 mm)
Shipping	35 7/8" (910 mm)	37 1/4" (945 mm)	42 3/8" (1075 mm)

Weight	
Max Per Shelf	22 lbs
Max Load Size	44 lbs
Net	229 lbs
Shipping	255 lbs

Size	Electric. 60 hz	Breaker	Cable connection	Running Amps
XS	208V 3 PH	30A*	15-30P	16.5 amps
XS	240V 3 PH	30A	15-30P	19.0 amps
XS*	208V 1 PH	50A	6-50P	27.5 amps
XS*	240V 1 PH	50A	6-50P	31.5 amps

EACH XS unit is supplied with 8 ft 14-3 AWG cord and plug. *Rated for 30 amp breaker due to plug size, 20 amp breaker is adequate. Use copper wire only. 3Ph 4-wire system (3 wire w/ ground)-dedicated 3 pole circuit breaker required. 1 Ph L1, L2, G-dedicated 2 pole circuit breaker required. 208 v is field retrofittable to 240v, 480v is field retrofittable to 440v. Do not use fuses. Supplied with an external data interface (splashwater proof LAN socket RJ45).

Thermal load and airflow requirements

Latent	283 W
Sensible	375 W
Unit free standing	13314 ft³/h
One side against a wall	8405 ft³/h
Noise values	65 dBA
Extraction power	9,900-20,000 ft³/h

Clearance Requirements

To facilitate servicing, we recommend leaving a 18"-20" (450-500 mm) gap on the left-hand side of the unit. If there is not 18"-20" (450-500 mm) left side clearance available, provisions for moving the unit or appliance to the left for service access must be made. These include, but are not limited to, having quick connections (water, gas, etc.) and lengthened electrical connections with flexible cords. If there are no external heat sources acting on the unit, there should be a minimum gap of 2" (50 mm) to the left, right, and back of unit. If a high temperature heat source is on the left side of the unit, the left-hand gap must be a minimum of 14" (350 mm). This gap may be reduced to 2" (50 mm) by using a heat shield (see options). Recommended clearance from unobstructed rear exhaust pipes and any surface collecting grease or flammable material; 16" (400 mm) gas, 10" (254 mm) electric. It is recommended to have a hood overhang of 6" (150 mm) to 18" (450 mm) at the front of the unit and 6" (150 mm) on the side if installed at the end of the cooking line. Please refer to the Installation Manual for further technical data and for instructions on installation and setup. Installations must comply with all local electrical, plumbing, and ventilation codes. The local standards and regulations for ventilation systems must be adhered to.

Water Requirements

Connection	3/4" GHT
Supply	Minimum 1/2" ID Drinking Quality Cold
Pressure	21-87 psi (1.5-6 bar)
Average Treated Water Consumption	1 gal/h
Min/Max Flow Rate	3 gpm/5.3 gpm
Water Drain	1 1/2" OD (40 mm) hub

Connect only to 2" (XS = 1 1/2") high-temperature resistant pipe. Water discharge temperature can be field adjusted to meet section 701.7 of the International Plumbing Code. Contact RATIONAL for back flow recommendation.

Water Quality

Untreated water can be 0 to 24.5 gr/gal (0 to 420ppm) hardness. We do not recommend treated water hardness < 5 gr/gal (86ppm) because the water could be corrosive. Sodium ion exchangers are not recommended; H+ Ion exchange systems are recommended. Water that does not meet the following minimum standards will require the proper conditioning.

Contaminant	Water Requirements	If > than recommended
Sand/Particles	< 15 µm	Particle filter
Chlorine (Cl ₂)	< 0.12 gr/gal (0.2 ppm)	Active carbon filter
Chloride (Cl ₋)	< 4.68 gr/gal (80 ppm)	RO or deionization

RATIONAL USA Inc.

1701 Golf Road, Suite C-120, Commerce
Rolling Meadows, IL 60008
Toll Free: 888-320-7274, Fax.: 847-755-9583

Visit us on the internet: www.rationalusa.com

We reserve the right to make technical improvements



Specification

Tue Oct 23 16:35:15 CEST 2018

SelfCookingCenter® SCC XS E (4 x 13 x 18 inch) UltraVent Plus XS

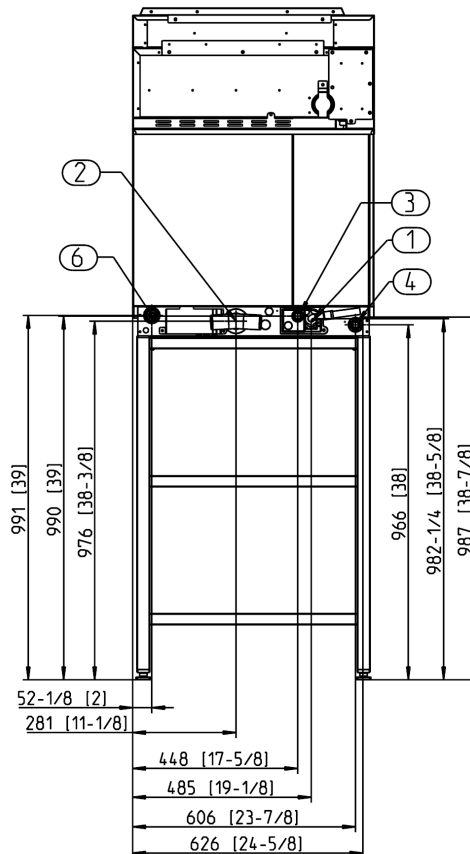
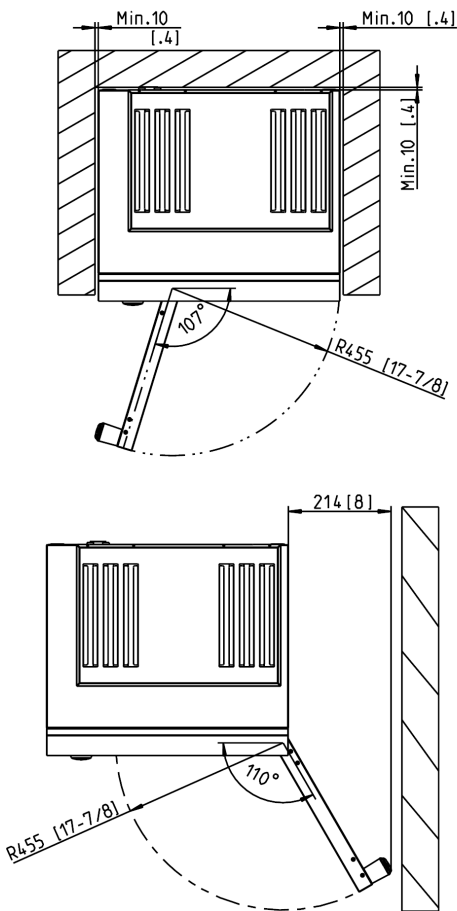
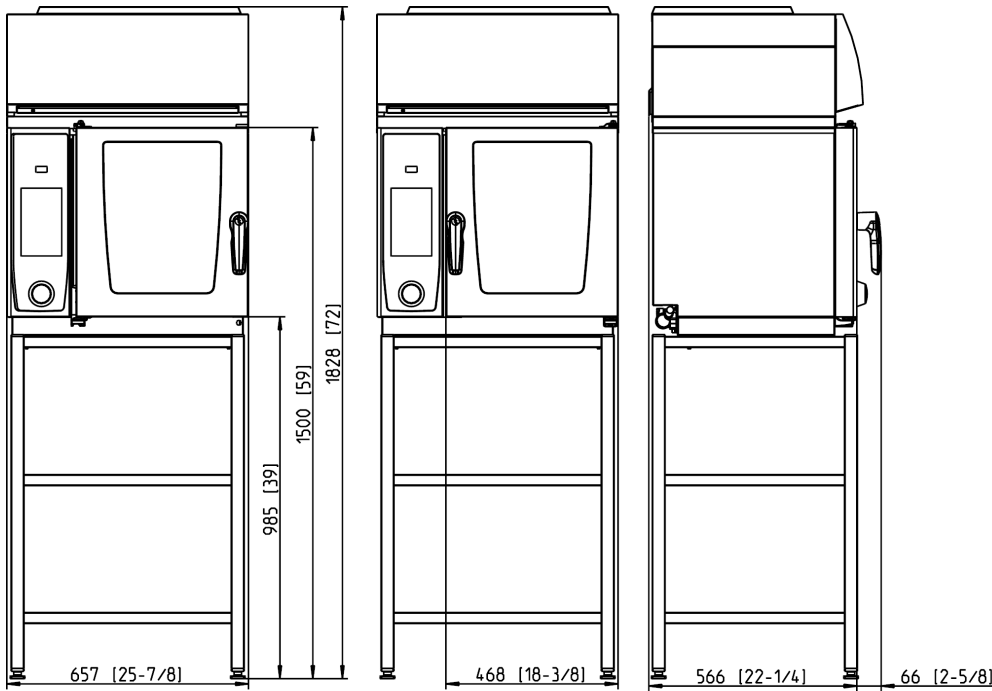

1. Common water supply (cold water) "Single" water connection as shipped 2. Drain 3. Electrical connection wire entrance 4. Chassis Ground connection 5. Steam Vent pipe 2 3/8" / 60mm 6. Splashwater-proof Ethernet socket RJ45; Minimum Clearance 1/2" / 50 mm Left side clearance 20" recommended for servicing of unit without the ability to move unit while connected. Measurements in mm (inch)



Specification

Tue Oct 23 16:35:15 CEST 2018

SelfCookingCenter® SCC XS E (4 x 13 x 18 inch) UltraVent Plus XS

ELECTRICAL OPTIONS (all 60Hz) Special voltages available upon request

Voltage / breaker / running amps / AWG	Voltage / breaker / running amps / AWG
<input type="checkbox"/> 208V 1 Ph / 50 / 27.5 / #8 - field retrofittable to 240 V	<input type="checkbox"/> 240V 1 Ph / 50 / 31.5 / #8
<input type="checkbox"/> 208V 3 Ph / 30 / 16.5 / #12 - field retrofittable to 240 V	<input type="checkbox"/> 240V 3 Ph / 30 / 19 / #12

ACCESSORIES

<input type="checkbox"/> Installation Kits – include electrical, water and drainage connection	
<input type="checkbox"/> 208 or 240/60/1Ph- copper drain	87.01.404US
<input type="checkbox"/> 208 or 240/60/1Ph- CPVC drain	87.01.403US
<input type="checkbox"/> 208 or 240/60/3Ph- copper drain	87.01.402US
<input type="checkbox"/> 208 or 240/60/3Ph- CPVC drain	87.01.201US
<input type="checkbox"/> RATIONAL Cleaner Tabs without phosphorous – guarantee maximum cleaning power	56.00.210A
<input type="checkbox"/> RATIONAL Care Tabs – prevents scale deposits	56.00.562
<input type="checkbox"/> Certified installation by RATIONAL SERVICE-PARTNERS	See document
<input type="checkbox"/> RATIONAL Single Water Filter- for all single models and Combi-Duo XS/XS, 61/61 and 61/101	1900.1154US
<input type="checkbox"/> UG I stationary stand	60.31.018
<input type="checkbox"/> UG I stationary stand for Combi-Duo	60.31.020
<input type="checkbox"/> UG II stationary stand- 8 sets of support rails	60.31.044
<input type="checkbox"/> UG II stationary stand for Combi-Duo- 4 sets of support rails	60.31.046
<input type="checkbox"/> UG XS stand- adjustable by 1 ½“ on uneven work surface	60.31.029
<input type="checkbox"/> Stackable Combi-Duo kit, – for stacking XS on XS, right-hinged doors	60.73.768
<input type="checkbox"/> Stackable Combi-Duo kit, – for stacking XS on XS, left-hinged doors	60.74.276
<input type="checkbox"/> Wall bracket- for space-saving wall assembly	60.30.968
<input type="checkbox"/> Combi-Duo UltraVent XS or UltraVent Plus XS adapter kit	60.73.945
<input type="checkbox"/> RATIONAL USB data-memory stick – for transferring cooking programs and HACCP data	42.00.162
<input type="checkbox"/> Heat shield for left side panel	60.74.182
<input type="checkbox"/> Hinging rack – 11 racks	60.73.724
<input type="checkbox"/> Hinging rack – 7 racks–standard with the unit	60.74.331
<input type="checkbox"/> For a full list of ¾ size accessories for ideal grilling, baking, roasting, frying, rotisserie, steaming, Finishing®, and much more	See accessories brochure

FACTORY INSTALLED OPTIONS (special order)

- Left-hinged door 208V / 240V / 1PH | 208V / 240V / 3PH
- Door safety lock – handle is turned left then right before the door can be opened
- Marine Version