



Model: **H-122** Item #: _____ Date: _____

Project: _____ Qty: _____ Approved By: _____

Wall Mount Automatic Foam Soap Dispenser



DESCRIPTION

- Wall Mount Automatic Foam Soap Dispenser, activated by touch-free infrared sensor, to be filled with foaming soap

STANDARD FEATURES

- Touch-free sensor
- Mounting screws included
- Safety lock with key
- Site window to see remaining soap
- Refillable soap container
- Compatible with Krowne H-162 Countertop Stand, H-160 Dispenser Drip Tray, and H-165 Floor Stand
- Uses 4 C Batteries (not included)

SPECIFICATIONS

Capacity	1000mL
Height	11-1/4"
Width	6-3/8"
Depth	4-5/8"
Weight	2.5lb

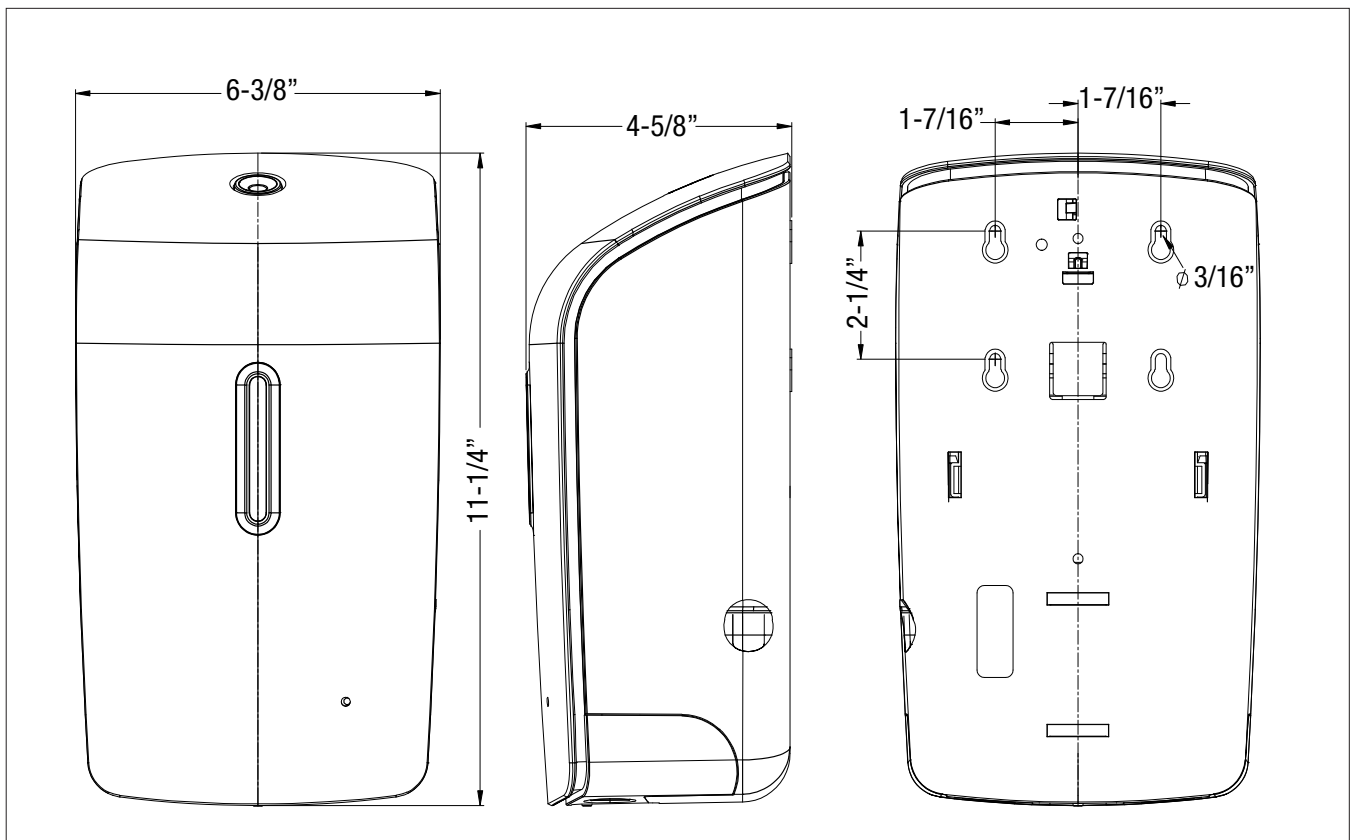

California Proposition 65 Warning

Krowne Metal Corporation • 100 Haul Rd. Wayne, NJ 07470 • P: (800) 631-0442 • customerservice@krowne.com • krowne.com

Due to our commitment to continued product improvement, specifications are subject to change without notice.

Rev. 4/2021 • No. H-122