



# ULR67B-D4

## Undercounter 67" Refrigerator with Drawers



ULR67B-D4  
09/09/24  
Item # 13693

### W x D x H

67" x 33.25" x 33.875"\*  
\*with 4" casters

Item #: \_\_\_\_\_

Project: \_\_\_\_\_

Qty: \_\_\_\_\_

AIA#: \_\_\_\_\_



### Dimensions / Capacity

<b>Interior Storage Capacity</b> (CF) (AHAM)	19.97 ft <sup>3</sup>
<b>Overall Width x Depth</b> (including 1" bumper)	67" x 33.25"
<b>Height</b> (including 4" casters)	33.875"
<b>Drawer Opening Width x Depth</b>	22.5" x 9"
<b>Depth with Drawer Fully Open</b> (including 1" bumper)	57.5"
<b>Crated Weight</b>	443 lbs.
<b>Crated Length x Width x Height</b>	70.75" x 35.75" x 36"

### Two-Section ULR67B-D4

### Electrical / Refrigeration

<b>Voltage</b>	115/60/1
<b>HACR Breaker</b>	15.0 Amps
<b>Electrical Connection</b> (NEMA)	5-15P ⚡
<b>Voltage Range</b>	104-126
<b>Ambient Temp. Range</b>	45° to 100°F
<b>Control Setpoint Range</b>	28° to 45°F
<b>Recommended Setpoint</b>	36°F
<b>Amperage</b>	3
<b>Energy Consumption</b> (kWh/day) @NSF	1.33
<b>Heat Rejection</b> (BTU/Hr.) @NSF	381
<b>Approx. Nominal Compress.</b> BTU/HR (HP)	1354 (1/5HP)
<b>Refrigerant / Charge Amount</b> (oz)	R290 (2.2 oz)

### Two-Section ULR67B-D4

## Features

- ▶ Engineered to maintain NSF-7 temperatures in 100°F ambient.
- ▶ Stainless steel exterior front, sides, and top with stainless steel interior sides, back, and floor
- ▶ Front breathing air flow design
  - Environmentally friendly R290 hydrocarbon refrigerant
  - Cabinet and drawers are insulated with 2" CFC free, foamed in place polyurethane
  - Drawer slides are constructed of 14 gauge stainless steel with acetal rollers
  - Drawer frames are formed of 14 gauge stainless steel and securely fastened in the cabinet
  - Drawers will accommodate (2) 12 x 20" full size, 6" deep pans (pans by others)
  - Drawer slides have a dynamic load capacity of 250 lbs.
  - Extruded aluminum flush mount drawer handle
  - Magnetic drawer gasket is easily removable for cleaning
  - Removable air filter for easy cleaning
  - Hot gas condensate removal
  - Mullion heaters for reduced condensation
  - Digital temperature display
  - E-coated evaporator coil
  - Standard with 4" casters (two with brakes)
  - 10 ft. cord and plug

### Options

- 2" Casters (HS-5037, set of 4)
- 6" Casters (HS-5036, set of 4)
- Overshelves (HS-5231, single)
- Overshelves (HS-5230, double)
- Drawer divider bar (HS-4007, Vertical)
- Drawer divider bar (HS-5691, Horizontal)
- Stainless steel back panel (factory request)
- Drawer locks (factory request)



Valid in United States, Canada, Puerto Rico and U.S. Territories. Contact factory for warranty in other countries.

If GFCI is required, a GFCI breaker MUST be used in lieu of GFCI receptacle

Hoshizaki reserves the right to change specifications without notice.



# ULR67B-D4

Undercounter 67" Refrigerator with Drawers



ULR67B-D4  
09/09/24  
Item # 13693

FRONT VIEW

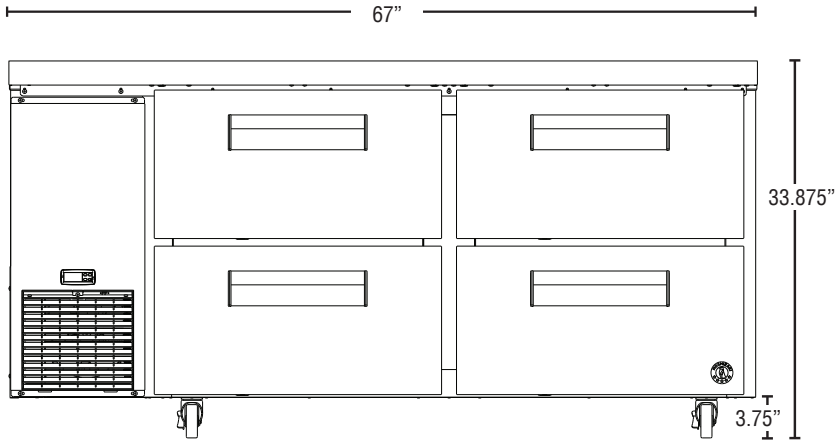

SIDE VIEW

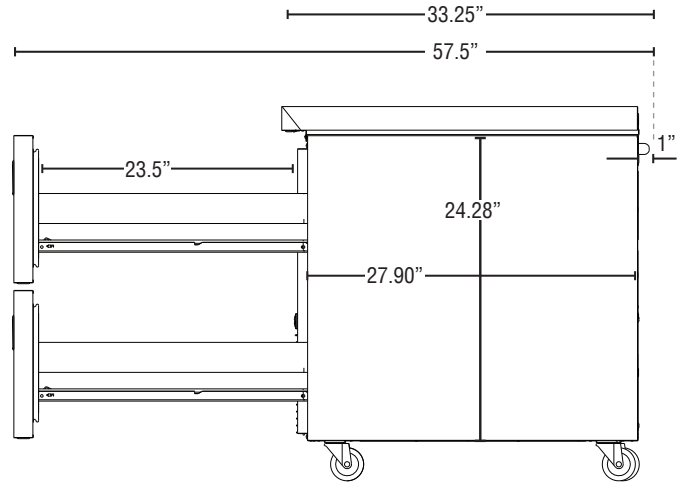

PLAN VIEW

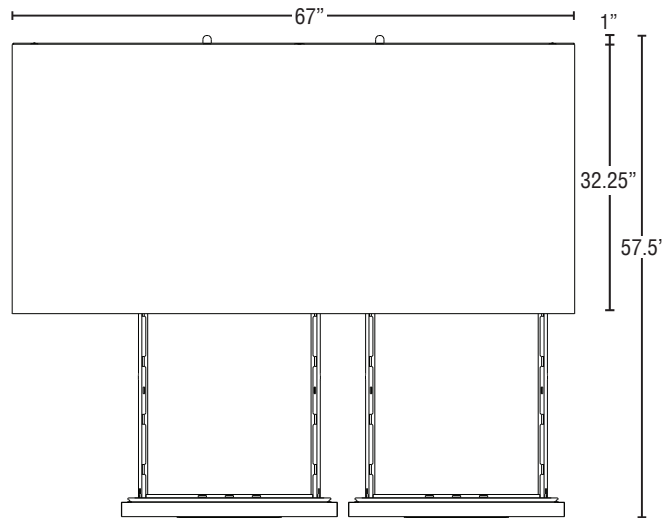

### Cabinet Construction

The exterior cabinet top, front, and sides, are constructed of high quality stainless steel. The exterior back and bottom are constructed of coated steel. The cabinet interior features stainless steel back, sides, and floor with a stainless steel top. Mounted on anodized aluminum pilasters the shelves are adjustable in 1/2" increments. Cabinet walls are insulated with 2" CFC free, foamed in place polyurethane. 4" polyolefin, stem casters (two with brakes) are standard.

### Drawer Construction

Drawer fronts are constructed of high grade stainless steel with stainless steel interior and are insulated with 2" CFC free, foamed in place polyurethane. Each drawer accommodates (2) 12" x 20" x 6" deep pans (pans by others). Drawer frames are formed of 14 gauge stainless steel all welded construction and securely fastened in the cabinet. The drawer slides are constructed of heavy duty 14 gauge stainless steel and durable acetal rollers with stainless steel ball bearings to prevent metal to metal contact. The drawer slides have a dynamic load capacity of 250 lbs. and have been life tested (fully loaded) three hundred thousand cycles without showing significant wear. The flush mount handles are constructed of extruded aluminum. Snap-in magnetic drawer gaskets are durable and easily removed for cleaning.

### Refrigeration System

The high efficiency refrigeration system is self-contained with an E-coated evaporator for extended life. Condensate removal is accomplished with an energy efficient non-electric evaporation system. A capillary tube controls the flow of environmentally friendly R290 refrigerant through the evaporator. Refrigeration system utilizes an off-cycle defrost to eliminate any ice on the evaporator coil. 115 volt units are equipped with a ten foot cord and plug (20.0 amps or less).