



HOSHIZAKI

Service Manual

Modular Crescent Cuber

Models

KM-350MAJ, MWJ

KM-420MAJ, MWJ, MRJZ

KM-520MAJ, MWJ, MRJ(Z)

KM-660MAJ, MWJ, MRJ(Z)



hoshizakiamerica.com

Number: 73230
Issued: 10-29-2018
Revised: 11-7-2023

⚠ WARNING

Only qualified service technicians should install and service the appliance. To obtain the name and phone number of your local Hoshizaki Certified Service Representative, visit www.hoshizaki.com. No service should be undertaken until the technician has thoroughly read this Service Manual. Failure to service and maintain the appliance in accordance with this manual will adversely affect safety, performance, component life, and warranty coverage. Proper installation is the responsibility of the installer. Product failure or property damage due to improper installation is not covered under warranty.

Hoshizaki provides this manual primarily to assist qualified service technicians in the service of the appliance.

Should the reader have any questions or concerns which have not been satisfactorily addressed, please call, send an e-mail message, or write to the Hoshizaki Technical Support Department for assistance.

Phone: 1-800-233-1940; (770) 487-2331

Fax: 1-800-843-1056; (770) 487-3360

E-mail: techsupport@hoshizaki.com

HOSHIZAKI AMERICA, INC.

618 Highway 74 South

Peachtree City, GA 30269

Attn: Hoshizaki Technical Support Department

Web Site: www.hoshizaki.com

NOTE: To expedite assistance, all correspondence/communication **MUST** include the following information:

- Model Number _____
- Serial Number _____
- Complete and detailed explanation of the problem.

IMPORTANT

This manual should be read carefully before the appliance is serviced. Read the warnings and guidelines contained in this manual carefully as they provide essential information for the continued safe use, service, and maintenance of the appliance. Retain this manual for any further reference that may be necessary.

CONTENTS

Important Safety Information	5
I. Construction and Water/Refrigeration Circuit Diagrams	7
A. Construction	7
1. Air-Cooled Models (MAJ)	7
2. Water-Cooled Models (MWJ)	8
3. Remote Models (MRJ, MRJZ)	9
B. Water/Refrigeration Circuit Diagrams	10
1. Air-Cooled Models (MAJ)	10
2. Water-Cooled Models (MWJ)	11
3. Remote Models (MRJ, MRJZ)	12
II. Sequence of Operation and Service Diagnosis	13
A. Sequence of Operation Flow Charts	13
1. Operation Flow Chart	13
2. Shutdown Flow Chart	14
B. Service Diagnosis	15
1. K Control Board (2A8242-02) with Ultrasonic Bin Control	15
2. K Control Board (2A8242-02) with Mechanical Bin Control	22
3. K+ Control Board (2A9678-01) with Ultrasonic Bin Control	29
C. Control Board Check	36
D. Bin Control Check, Adjustment, and Cleaning	38
E. Float Switch Check and Cleaning	44
F. Thermistor Check	46
G. Control Switch	46
H. Mode Switch	46
I. Diagnostic Tables	47
J. Freeze-Up Check List	51
III. Controls and Adjustments	52
A. Control Board Layout	53
1. K Control Board (2A8242-02)	53
2. K+ Control Board (2A9678-01)	54
B. LED Lights and Audible Alarm Safeties	55
1. K Control Board (2A8242-02)	55
2. K+ Control Board (2A9678-01)	56
C. Settings and Adjustments	57
1. Default Dip Switch Settings	57
2. Harvest Time (S4 dip switch 1 & 2)	58
3. Pump-Out Time/Harvest Time During Pump-Out (S4 dip switch 3 & 4)	58
4. Pump-Out Frequency Control (S4 dip switch 5)	59
5. Harvest Pump Time (Harvest Assist) (S4 dip switch 6)	59
6. Harvest Pump Time (Harvest Assist) (S4 dip switch 7)	60

7. Factory Use (S4 dip switch 8).....	60
8. Freeze Timer (S4 dip switch 9 & 10)	60
9. Float Switch Selector (S5 dip switch 1)	61
10. Refill Counter (S5 dip switch 2 and 3).....	61
11. Minimum Harvest Time (S5 dip switch 4)	61
12. Anti-Slush (S5 dip switch 5)	62
IV. Refrigeration Circuit and Component Service Information.....	63
A. Refrigeration Circuit Service Information	63
B. Refrigeration Circuit Service Information	66
C. Component Service Information	69
D. Water Regulating Valve Adjustment (water-cooled model)	69
V. Maintenance	70
VI. Preparing the Appliance for Periods of Non-Use	71
VII. Disposal.....	73
VIII. Technical Information.....	74
A. Specification and Performance Data Sheets.....	74
1. KM-350MAJ	74
2. KM-350MWJ.....	75
3. KM-420MAJ.....	76
4. KM-420MWJ.....	77
5. KM-420MRJZ with URC-5FZ.....	78
6. KM-520MAJ.....	79
7. KM-520MWJ	80
8. KM-520MRJ with URC-5F	81
9. KM-520MRJZ with URC-5FZ.....	82
10. KM-660MAJ	83
11. KM-660MWJ.....	84
12. KM-660MRJ with URC-5F	85
13. KM-660MRJZ with URC-5FZ.....	86
B. Wiring Diagrams	87
1. K Control Board (2A8242-02) with Ultrasonic Bin Control	87
2. K Control Board (2A8242-02) with Mechanical Bin Control.....	88
3. K+ Control Board (2A9678-01) with Ultrasonic Bin Control	89

Important Safety Information

Throughout this manual, notices appear to bring your attention to situations which could result in death, serious injury, damage to the appliance, or damage to property.

⚠ WARNING Indicates a hazardous situation which could result in death or serious injury.

NOTICE Indicates a situation which could result in damage to the appliance or property.

IMPORTANT Indicates important information about the use and care of the appliance.

⚠ WARNING

The appliance should be destined only to the use for which it has been expressly conceived. Any other use should be considered improper and therefore dangerous. The manufacturer cannot be held responsible for injury or damage resulting from improper, incorrect, and unreasonable use. Failure to service and maintain the appliance in accordance with this manual will adversely affect safety, performance, component life, and warranty coverage and may result in costly water damage.

To reduce the risk of death, electric shock, serious injury, or fire, follow basic precautions including the following:

- Only qualified service technicians should install and service this appliance.
- The appliance must be installed in accordance with applicable national, state, and local codes and regulations.
- Electrical connection must be hard-wired and must meet national, state, and local electrical code requirements. Failure to meet these code requirements could result in death, electric shock, serious injury, fire, or severe damage to equipment.
- The icemaker requires an independent power supply of proper capacity. See the nameplate for electrical specifications. Failure to use an independent power supply of proper capacity can result in a tripped breaker, blown fuses, damage to existing wiring, or component failure. This could lead to heat generation or fire.
- **THE ICEMAKER MUST BE GROUNDED.** Failure to properly ground the icemaker could result in death or serious injury.
- Move the control switch to the "OFF" position and turn off the power supply before servicing. Lockout/Tagout to prevent the power supply from being turned back on inadvertently.
- To reduce the risk of electric shock, do not touch the control switch with damp hands.
- Do not make any alterations to the unit. Alterations could result in electric shock, injury, fire, or damage to the unit.
- The appliance is not intended for use by persons (including children) with reduced physical, sensory, or mental capabilities, or lack of experience and knowledge, unless they have been given supervision or instruction concerning use of the appliance by a person responsible for their safety.

⚠ WARNING, continued

- Children should be properly supervised around this appliance.
- Do not climb, stand, or hang on the appliance or allow children or animals to do so. Serious injury could occur or the appliance could be damaged.
- Do not use combustible spray or place volatile or flammable substances near the appliance. They might catch fire.
- Keep the area around the appliance clean. Dirt, dust, or insects in the appliance could cause harm to individuals or damage to the appliance.

Additional Warning for Remote Models

- **THE REMOTE CONDENSER UNIT MUST BE GROUNDED.** The power supply and ground connection to the remote condenser unit are supplied from the icemaker. Failure to properly ground the remote condenser unit could result in death or serious injury.
- Move the icemaker control switch to the "OFF" position and turn off the power supply to the icemaker before servicing the remote condenser unit. Lockout/Tagout to prevent the power supply from being turned back on inadvertently.

NOTICE

- Follow the instructions in this manual carefully to reduce the risk of costly water damage.
- In areas where water damage is a concern, install in a contained area with a floor drain.
- Install the appliance in a location that stays above freezing. Normal operating ambient temperature must be within 45°F to 100°F (7°C to 38°C).
- Do not leave the icemaker on during extended periods of non-use, extended absences, or in sub-freezing temperatures. To properly prepare the icemaker for these occasions, follow the instructions in "VI. Preparing the Appliance for Periods of Non-Use."
- Do not place objects on top of the appliance.
- The dispenser unit/ice storage bin is for ice use only. Do not store anything else in the dispenser unit/ice storage bin.

I. Construction and Water/Refrigeration Circuit Diagrams

A. Construction

1. Air-Cooled Models (MAJ)

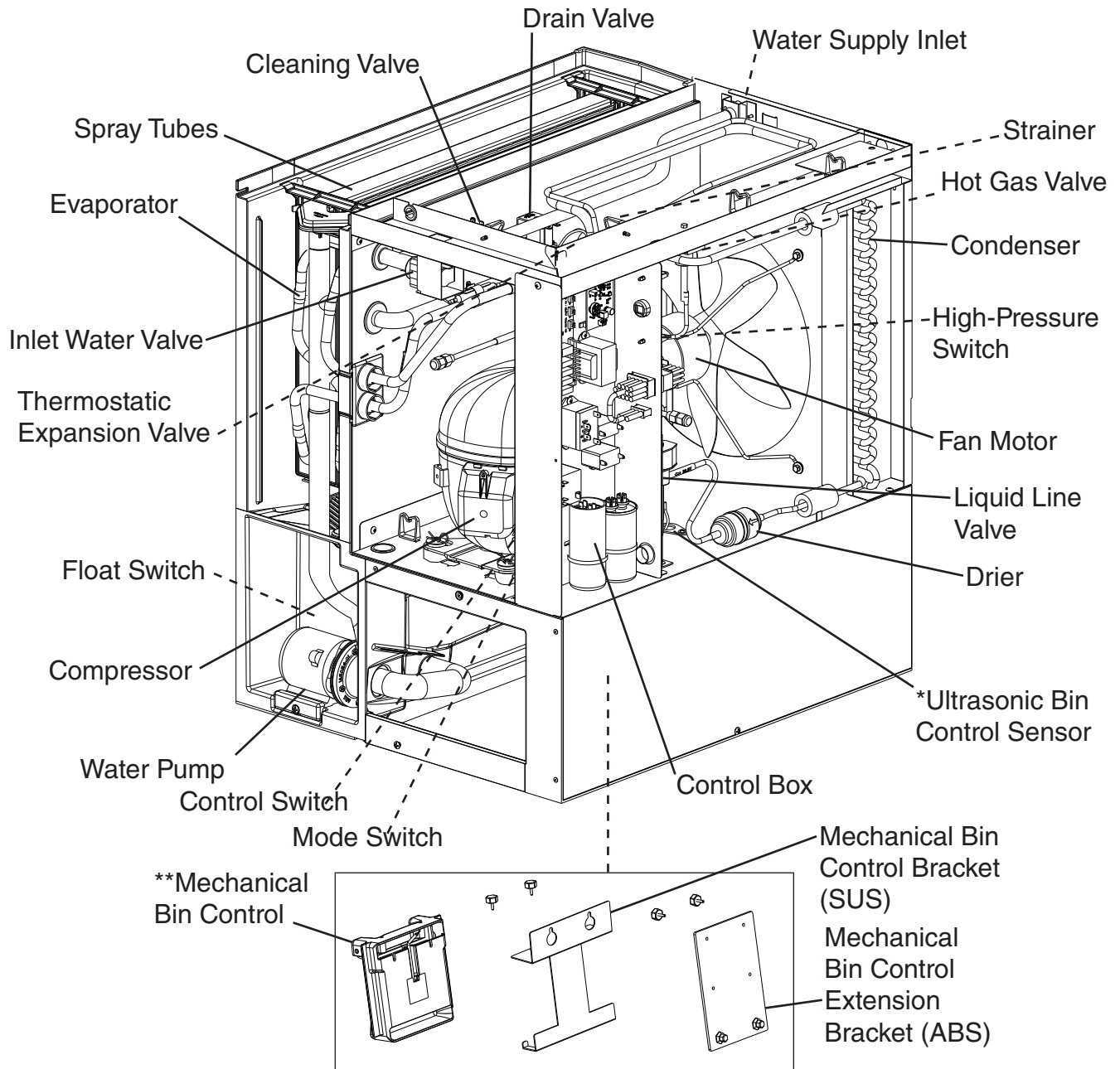

Model Shown: KM-350MAJ

Model	Bin Control Auxiliary Code Break	
	*Ultrasonic Bin Control Sensor	**Mechanical Bin Control
KM-350MAJ	L19076J and earlier, L19237K and later	L19077K to L19236K
KM-420MAJ	ALL	-
KM-520MAJ	L02152J and earlier, L02412K and later	L02153K to L02411K
KM-660MAJ	L05261J and earlier, L15442L and later	L05262K to L05441K

2. Water-Cooled Models (MWJ)

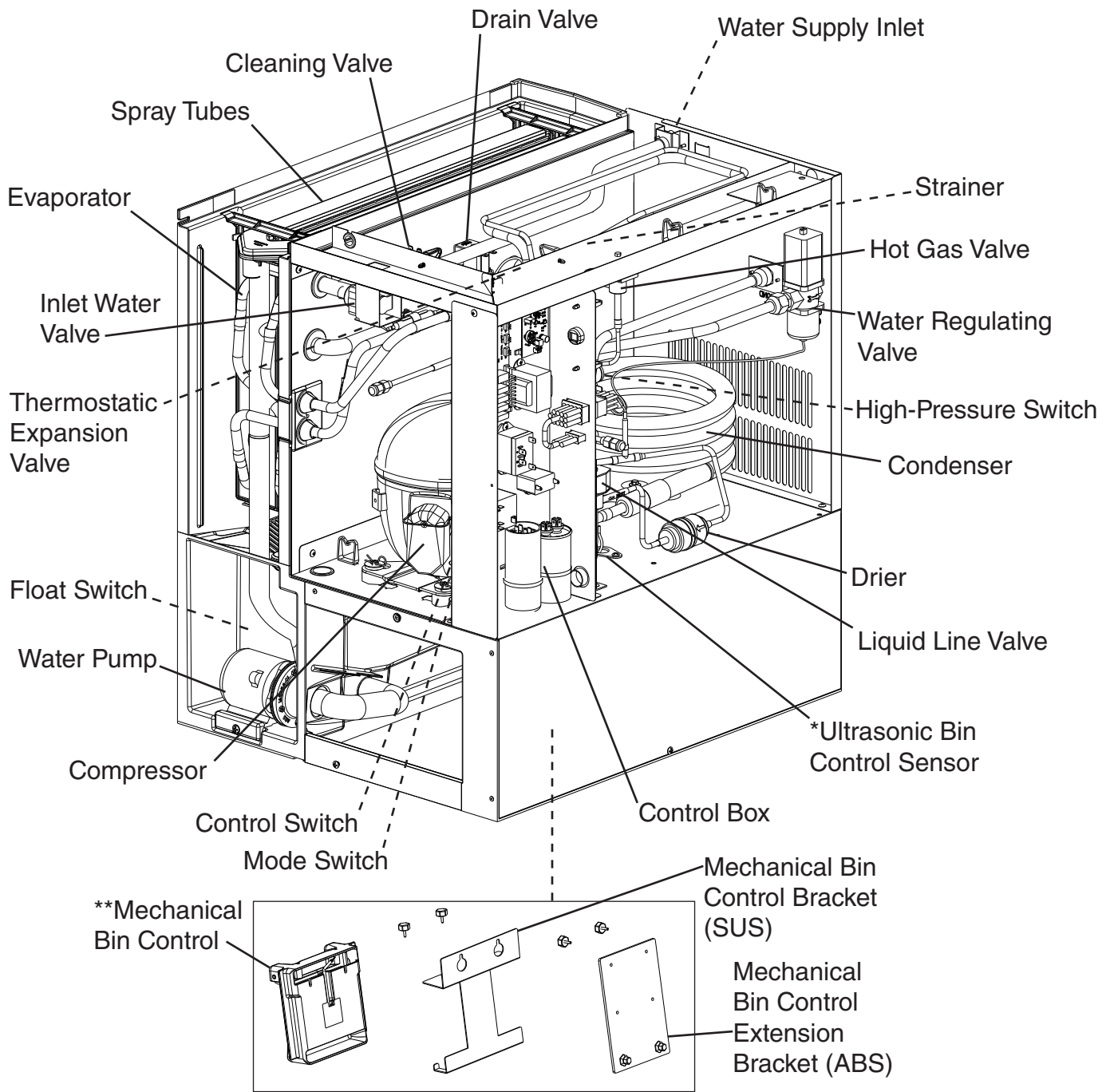

Model Shown: KM-520MWJ

Model	Bin Control Auxiliary Code Break	
	*Ultrasonic Bin Control Sensor	**Mechanical Bin Control
KM-350MWJ	H-0 and later	-
KM-420MWJ	ALL	-
KM-520MWJ	H-0 and later	-
KM-660MWJ	L00673J and earlier, L10694L and later	L00674K to L00693K

3. Remote Models (MRJ, MRJZ)

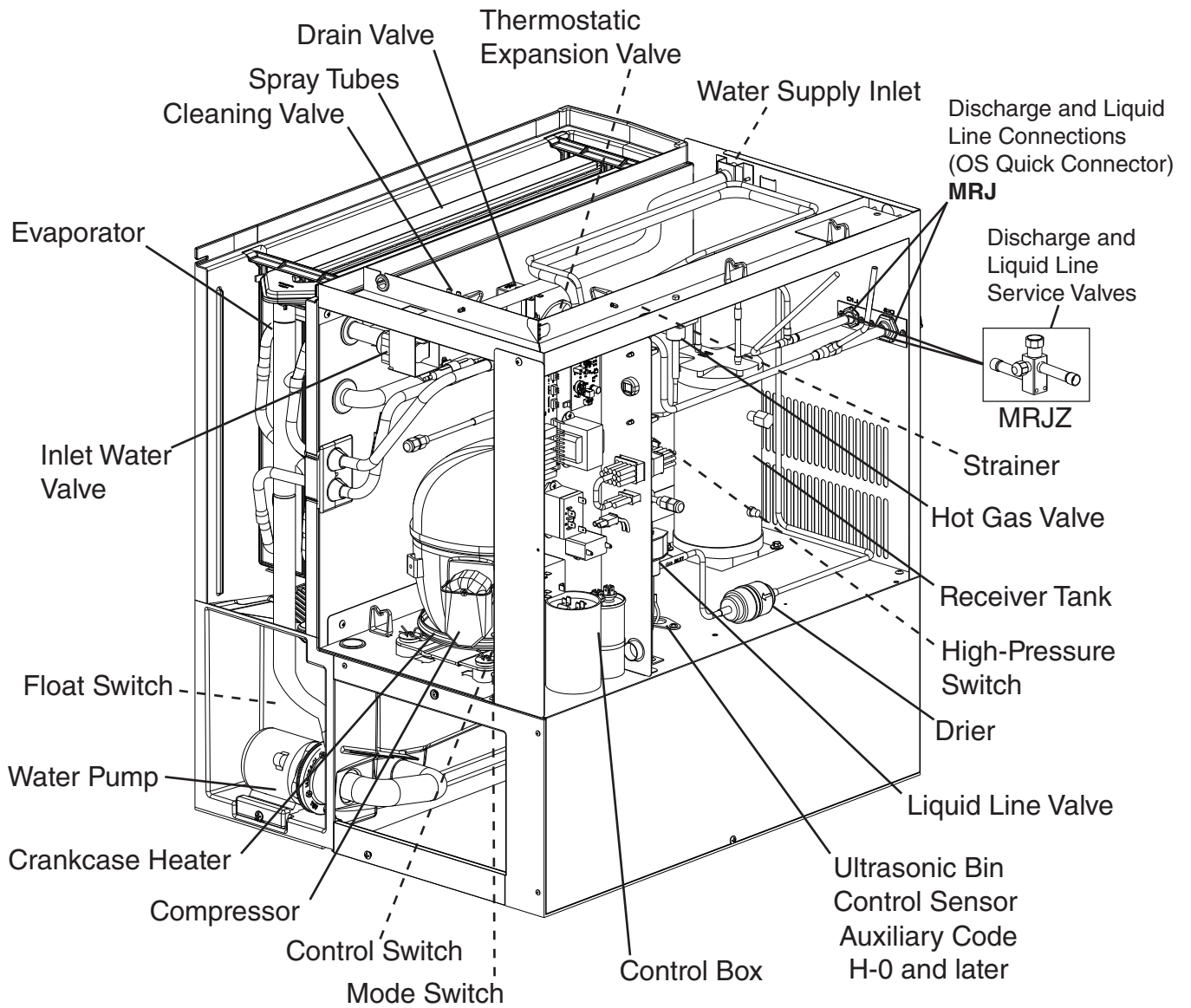

Model Shown: KM-660MRJ

B. Water/Refrigeration Circuit Diagrams

1. Air-Cooled Models (MAJ)

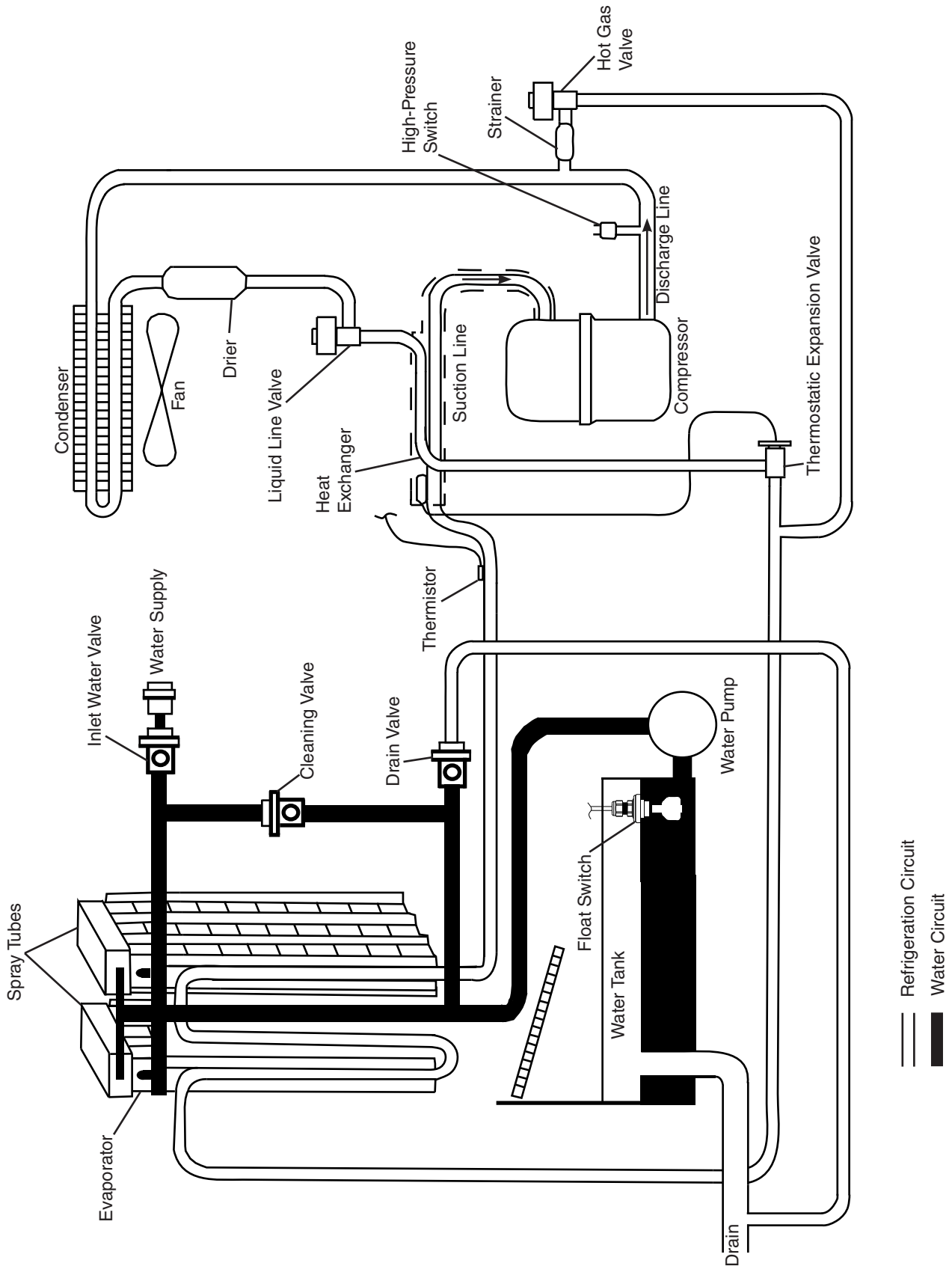

2. Water-Cooled Models (MWJ)

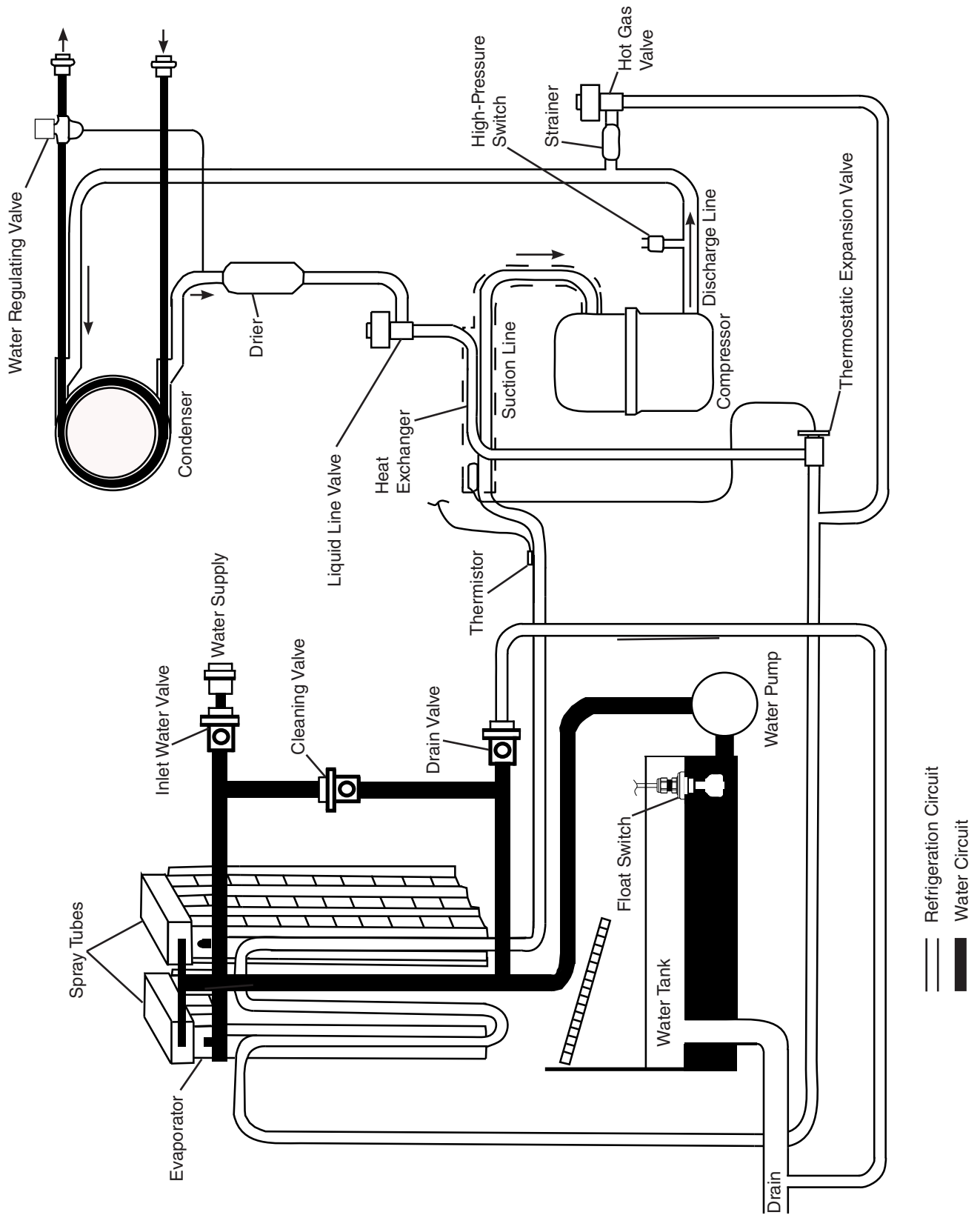

3. Remote Models (MRJ, MRJZ)

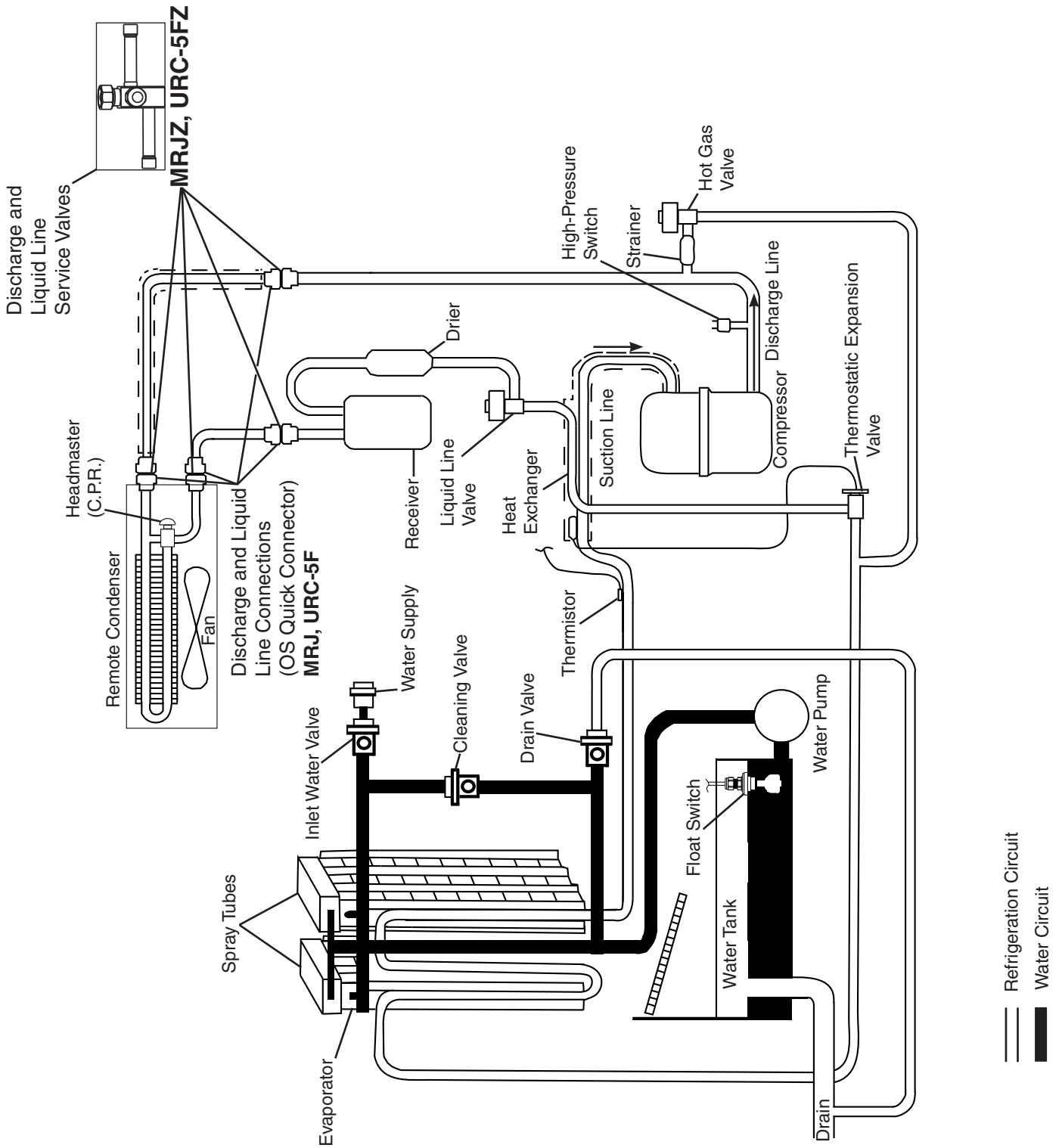

II. Sequence of Operation and Service Diagnosis

A. Sequence of Operation Flow Charts

1. Operation Flow Chart

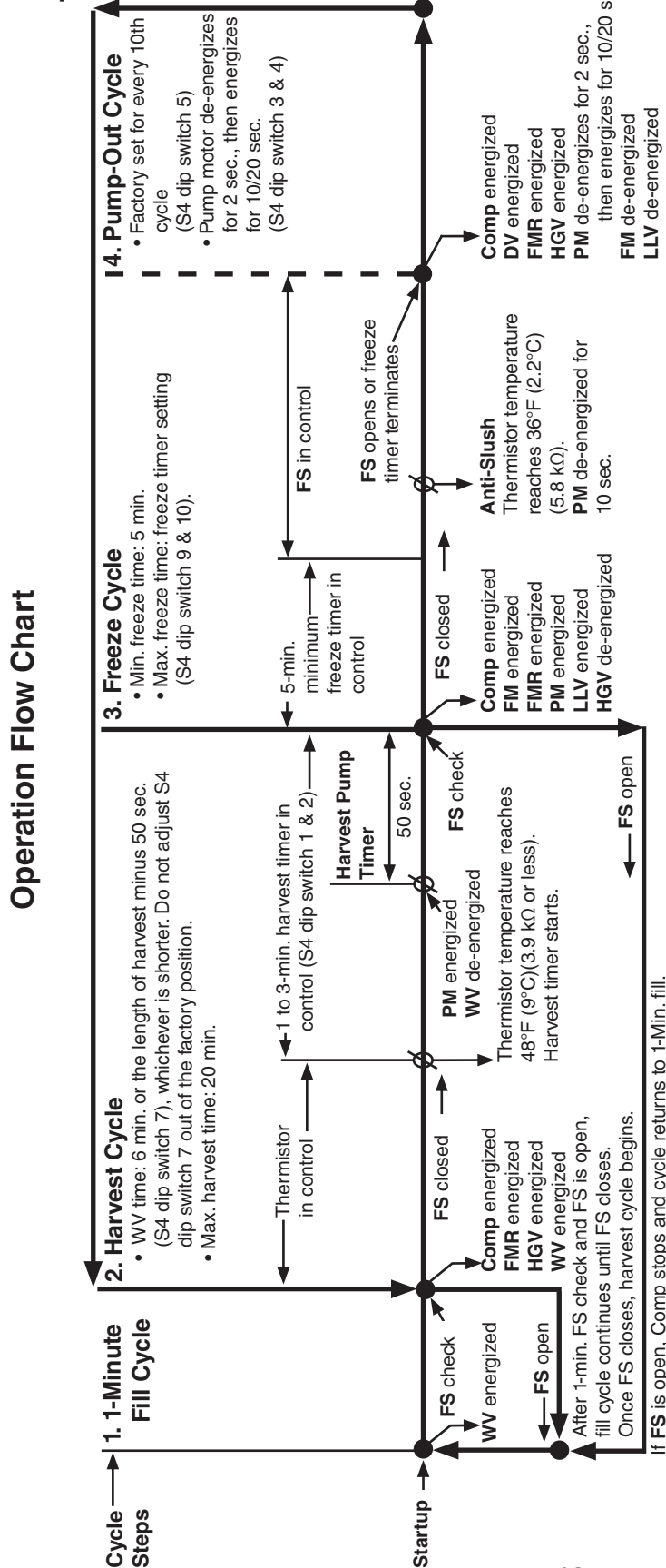

Components Energized when the Control Switch is in the "PUMP" Position

When the control switch is in the "PUMP" position, power is supplied to the pump motor. Water tank contents then flows over the outside of the evaporator plate assembly. Note: Water tank contents does not flow in-between the evaporator plates.

Components Energized when the Control Switch is in the "ON" or "PUMP" position and the Mode Switch is in the "CLEAN" Position

- When the control switch is in the "ON" position and the mode switch is in the "CLEAN" position, power is supplied to the control board K9 connector. The control board then initiates a clean/sanitize program. See the maintenance label on the top cover or the instruction manual for details.
- When the control switch is in the "PUMP" position and the mode switch is in the "CLEAN" position, only the pump motor energizes and circulates water tank contents over the outside of evaporator plate assembly, as the control board power supply has been disconnected. The Clean/Sanitize program cannot initiate in this scenario.

2. Shutdown Flow Chart

Shutdown Flow Chart

K Control Board (2A8242-02)

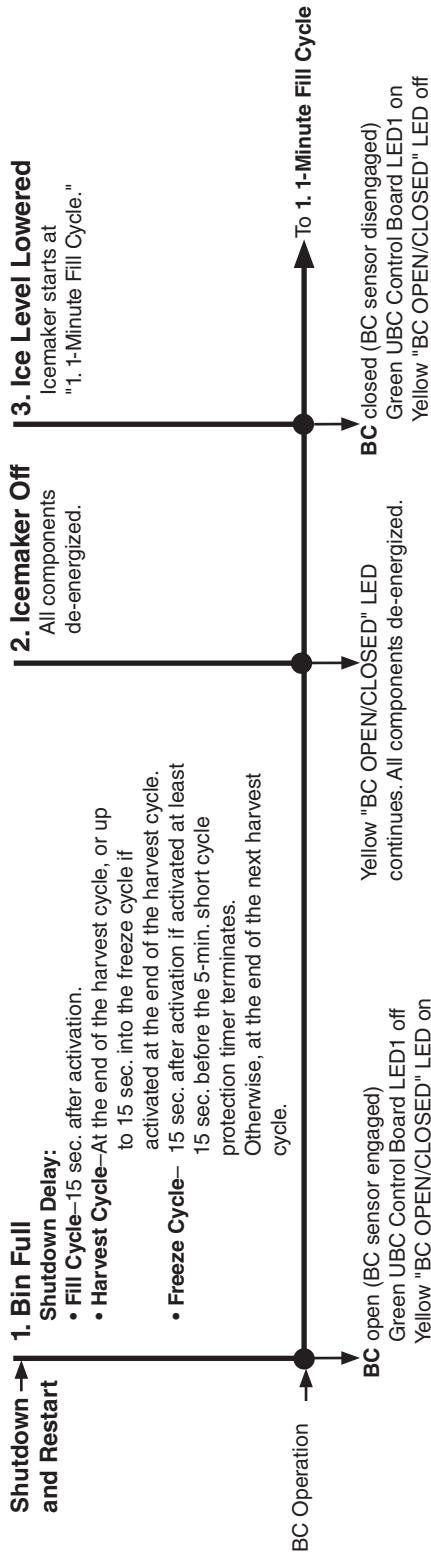

Legend:
BC—bin control
UBC—ultrasonic bin control

K+ Control Board (2A9678-01)

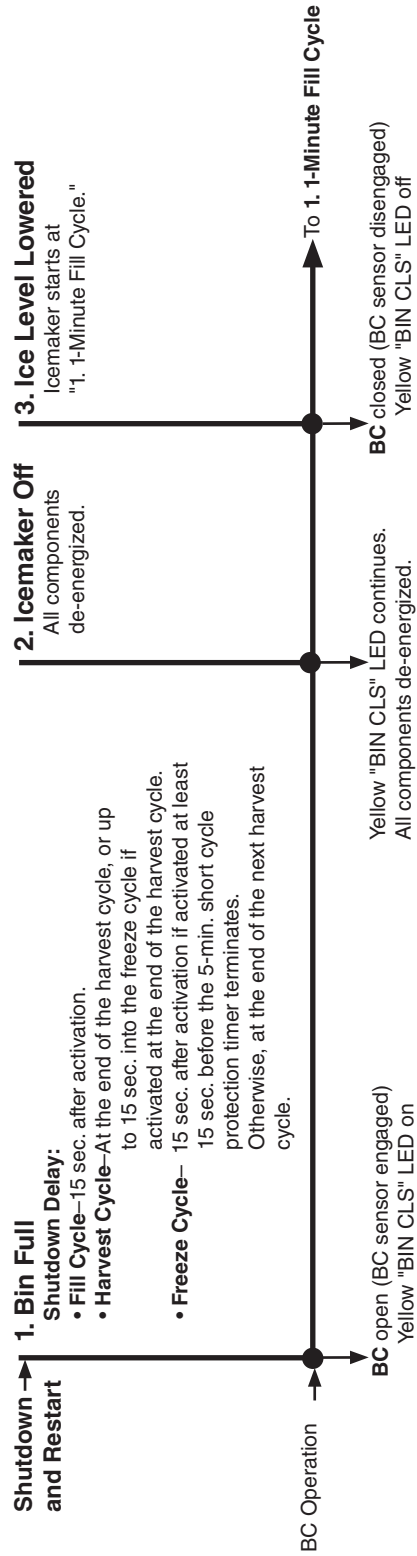

Legend:
BC—bin control

B. Service Diagnosis

1. K Control Board (2A8242-02) with Ultrasonic Bin Control

Used in conjunction with Ultrasonic Bin Control Board (4A6838-01)

Model	Auxiliary Code Break
KM-350MAJ	L19076J and earlier
KM-350MWJ	L10793J and earlier
KM-520MAJ	L02152J and earlier
KM-520MWJ	L00958J and earlier
KM-520MRJ	L00778J and earlier
KM-660MAJ	L05261J and earlier
KM-660MWJ	L00673J and earlier
KM-660MRJ	L00848J and earlier

WARNING

- The appliance should be diagnosed and repaired only by qualified service personnel to reduce the risk of death, electric shock, serious injury, or fire.
- Risk of electric shock. Control switch in "OFF" position does not de-energize all loads Use extreme caution and exercise safe electrical practices.
- Moving parts (e.g., fan blade) can crush and cut. Keep hands clear.
- Before servicing the appliance, move the control switch to the "OFF" position and turn off the power supply.
- **CHOKING HAZARD:** Ensure all components, fasteners, and thumbscrews are securely in place after the appliance is serviced. Make sure that none have fallen into the dispenser unit/ice storage bin.
- Make sure all food zones in the appliance and dispenser unit/ice storage bin are clean after service.

The diagnostic procedure is a sequence check that allows you to diagnose the electrical system and components. Before proceeding, check for correct installation, proper voltage per nameplate, and adequate water supply. Check CB using the steps in "II.C. Control Board Check." Check dip switch settings to assure that S4 dip switches and S5 dip switches 1 through 5 are in the factory default position. S4 dip switch 1, 2, 3, 4, and 5 are cleaning adjustments and the settings are flexible. For factory default settings, see "III.C.1. Default Dip Switch Settings."

Note: • When checking high voltage (115VAC), always choose a white (W) neutral wire to establish a good neutral connection.

- When checking voltage from the CB K1 connector (10 pin connector), pull CB K1 connector out slightly to allow room for multimeter test leads contact.

- 1) Turn off the power supply, then access the control box. Move the control switch to the "OFF" position. Clear ice from UBC sensing area.
- 2) Check that the 115VAC 10A fuse is good.

a) Sequence and Component Diagnosis

3) **Power On:** Turn on the power supply, then move the control switch to the "ON" position and the mode switch to the "ICE" position. A 5-sec. delay occurs. CB red "POWER OK" LED turns on and UBC control board green "LED 1" turns on.

Note: • CB red "POWER OK" LED remains on unless the 10.5VAC power supply is interrupted (K2 connector).

- Check CB using the steps in "II.C. Control Board Check." or UBC using steps in "II.D.1a. Ultrasonic Bin Control Check."

a) **Power On Diagnosis:** If CB red "POWER OK" LED is off, confirm 10A fuse is good. Check for 115VAC at control switch #2 (BK) to neutral (W) then at control switch #1 (P) to neutral (W). If 115VAC is present on #2 (BK) and not on #1 (P), replace control switch. If 115VAC is present on control switch #1 (P), check for 115VAC at HPS (P) to neutral (W) then HPS (BK) to neutral (W). If 115VAC is present at HPS (P) and not at HPS (BK), HPS is open. See HPS Diagnosis below. If 115VAC is present at HPS (BK), check for 10.5VAC at CB K2 #1 red wire to CB K2 #2 red wire. If 10.5VAC is not present, check CT continuity. If open, replace CT.

b) **Power On Ultrasonic Bin Control Diagnosis:** If CB red "POWER OK" LED and CB "BC OPEN/CLOSED" LED are on, and UBC control board "LED 1" LED is off. Clear UBC sensing area. If no object is in the area, replace UBC. If CB red "POWER OK" LED is on and CB "BC OPEN/CLOSED" LED and UBC control board "LED 1" LED are off, replace UBC control board. See "II.D. Ultrasonic Bin Control Check and Adjustment."

Note: UCB control board delay time:

Sensing Ice: UBC control board green "LED 1" LED turns off and CB "BC OPEN/CLOSED" LED turns after 5-sec. delay.

Not Sensing Ice: UBC control board green "LED1" LED turns on and CB "BC OPEN/CLOSED" LED turns off after 30-sec. delay.

b) **HPS Diagnosis:** Check that the condenser coil is not clogged or restricted. Let refrigeration circuit pressures equalize. If HPS does not reset and pressures are equalized, replace HPS. If pressures are not equalized, reclaim refrigerant and diagnose refrigeration circuit restriction. Check that there are no restrictions in the refrigeration circuit.

Harvest Cycle: HGV, strainer, or check valve.

Freeze Cycle: FM, FMR, TXV, WRV, HM, LLV, strainer, check valve, drier, and damaged line set or fitting.

Confirm that the location meets installation requirements:

- The appliance is not intended for outdoor use. Normal operating ambient temperature should be within 45°F to 100°F (7°C to 38°C).
- Allow 6" (15 cm) clearance at rear, sides, and top for proper air circulation and ease of maintenance and/or service should they be required.
- The appliance should not be located in a corrosive environment.

- 4) **1-Min. Fill Cycle – LED 4 is on.** WV energizes. After 1 min., CB checks for a closed FS. If FS is closed, the harvest cycle begins. If harvest cycle begins (Comp, HGV, FMR energized), continue to step 5a. If FS is open, fill cycle continues until FS closes (low water safety protection during initial start up and at the end of each harvest).
Diagnosis: Check that water enters the water tank. If not, check that the water supply line shut-off valve is open and screens or external filters are clear. Check for 115VAC at CB K1 #6 (O) to neutral (W). If 115VAC is not present, replace CB. If 115VAC is present, and WV does not energize, check for 115VAC at WV. If 115VAC is present, check coil continuity. If open, replace WV. If the water tank fills, but the appliance fails to start harvest (Comp energized), check for open FS. See "II.E. Float Switch Check and Cleaning." If FS is closed and CB fails to start the harvest cycle after 1 min., replace CB.
- 5a) **Initial Harvest Cycle – LEDs 1 and 4 are on.** WV continues. Comp, FMR, and HGV energize. CB monitors the warming of the evaporator via the thermistor located on the suction line. When the thermistor reaches 48°F (9°C), CB reads 3.9 kΩ from the thermistor and turns harvest termination over to the harvest timer (S4 dip switch 1 & 2 and S5 dip switch 4). WV are energized during harvest for a maximum of 6 min. or the length of harvest minus HPT setting (S4 dip switch 6), whichever is shorter. See step 5b below.
- a) **Comp Diagnosis:** Check that evaporator is warming. If not, confirm that Comp energizes. If not, check for 115VAC at CB K1 #9 (Y) to neutral (W). If 115VAC is not present, check for 115VAC at CB K1 #10 (BK) to neutral (W). If 115VAC is present at #10 (BK) and not at #9 (Y), replace CB. If 115VAC is present, check for 115VAC at mode switch #2 (Y) to neutral and mode switch #1 (V) to neutral. If 115VAC is present at #2 (Y) and not at #1 (V), confirm mode switch is in "ICE" position. If in "ICE" position, check mode switch continuity. If open, replace mode switch. If 115VAC is present at mode switch #1 (V), check for 115VAC at CR solenoid. If 115VAC is present, confirm contacts are closed. If not, replace CR. If CR contacts are closed, check Comp external overload, Comp start and run capacitors, Comp start relay, and Comp motor winding.
- b) **HGV Diagnosis:** If Comp is energized and evaporator is not warming, check that HGV energizes and opens. Check for 115VAC at CB K1 #2 (P) to neutral (W). If 115VAC is not present, check for 115VAC at CB K1 #1 (V). If 115VAC is not present, check wiring for loose connection from CB 10 pin connector pin #1 (V) to mode switch. If 115VAC is present on #1 (V) and not at #2 (P), replace CB. If 115VAC is present at #2 (P), check for 115VAC at HGV coil and check HGV coil continuity. Replace as needed.
- c) **LLV Diagnosis:** Confirm that LLV is de-energized and closed (not bypassing). If energized, replace CB. If de-energized and bypassing, replace LLV.
- d) **WRV Diagnosis:** Confirm WRV is not leaking by. If WRV is leaking by, confirm HGV is open and LLV is closed. Next, check for proper refrigerant pressures. If refrigerant pressures are correct, adjust or replace WRV. See "IV.C. Water Regulating Valve Adjustment (water-cooled models)."

5b) **Harvest Pump Time (Harvest Assist) – LEDs 1 and 3 are on.** When the thermistor reaches 48°F (9°C), CB reads 3.9 kΩ from the thermistor and turns harvest termination over to the harvest timer (S4 dip switch 1 & 2 and S5 dip switch 4). When WV de-energizes, LED 4 turns off and LED 3 turns on. PM energizes. Comp, FMR, and HGV continue.

Diagnosis: Place a thermometer on the suction line next to the thermistor. Has it warmed to 48°F (9°C) or warmer? Confirm thermistor status. See "II.F. Thermistor Check." If the thermistor reading is in proper range, dip switch 7 is on, and PM does not energize before harvest terminates, replace CB. If WV continues, check for 115VAC at CB K1 #6 (O). If 115VAC is present, and LED 4 is off, replace CB. If LED 3 is on and PM is not energized, check for 115VAC at CB K1 #4 (R). If 115VAC is not present, replace CB. If 115VAC is present and PM is not energized, check PM capacitor and motor winding continuity.

5c) **Initial Harvest Cycle Termination Diagnosis:** When the thermistor reaches 48°F (9°C), CB reads 3.9 kΩ from the thermistor and turns harvest termination over to the harvest timer (S4 dip switch 1 & 2 and S5 dip switch 4). Check discharge line temperature. For a thermistor check, see "II.F. Thermistor Check." If 1-min. fill cycle starts after harvest timer terminates, check that FS is clean and operating properly, see "II.E. Float Switch Check and Cleaning." If FS is closed, CB proceeds to the next cycle. If not, replace CB.

Note: The minimum total time allowed by CB for a complete harvest cycle is based on S5 dip switch 4. Maximum harvest time allowed is 20 min.

NOTICE! S4 dip switch 7 must remain on. Otherwise, PM will not energize during the last seconds of harvest.

6) **Freeze Cycle – LED 1, 2, and 3 are on.** Comp, FMR, and PM continue. FM and LLV energize. HGV de-energizes. Appliance is held in freeze by a 5-min. short cycle protection timer. After 5-min. short cycle protection timer terminates and FS opens, freeze cycle terminates.

Note: PM power supply continues from CB K1 #4 (R) in harvest and in freeze.

Anti-Slush: When anti-slush is enabled (S5 dip switch 5 "ON"), PM de-energizes when thermistor reaches 36°F (2.2°C) (5.8 kΩ) for 10 sec. then, energizes for the remainder of the freeze cycle.

a) **Freeze Cycle Diagnosis:** Confirm Comp, FMR, and PM continue. Confirm that FM and LLV energize. Confirm WRV opens. Next, confirm HGV de-energizes. During the first 5 min. of freeze, confirm evaporator is cooling. If not, confirm WV de-energized (not leaking by), HGV de-energized (not bypassing), LLV and FM energize, TXV and HM operate correctly, WRV opens, Comp is efficient, and refrigerant charge is correct. See "VIII.A. Specification and Performance Data Sheets."

- b) **Comp and FMR Diagnosis:** If Comp and FMR de-energize once freeze begins, check that appliance has not shut off on HPS (CB "POWER OK" LED off). If so, check "3)b HPS Diagnosis" above. If CB "POWER OK" LED is on, check for 115VAC at CB K1 #9 (Y) to neutral (W). If 115VAC is not present and LED 1 is on, replace CB. If 115VAC is present, check for 115VAC at CR coil. If 115VAC is present, check CR coil and contact continuity. Replace as needed. If CR is okay, check Comp start relay and start and run capacitors. Next, check Comp motor winding continuity. If Comp is energized but evaporator is not cooling, check for an inefficient Comp. See "VIII.A. Specification and Performance Data Sheets." If Comp is energized but FMR is not, check for 115VAC at the FMR junction box. If 115VAC is not present, check icemaker wiring connections. If 115VAC is present, check for voltage at condenser unit. If 115VAC is not present, check field wiring connections. If 115VAC is present, check FMR capacitor, motor winding, and fan blade for binding.
- c) **WV and HGV Diagnosis:** If WV is energized, check for 115VAC at CB K1 #6 (O) to neutral (W). If 115VAC is present after PM energizes in harvest cycle, replace CB. If 115VAC is not present, replace WV (bypassing). If HGV did not de-energize at the end of harvest, check for 115VAC at CB K1 #2 (P) to neutral (W). If 115VAC is present and LED 2 is on, replace CB. If 115VAC is not present, replace HGV (bypassing).
- d) **PM Diagnosis:** Confirm water is flowing over evaporator from PM and not WV. If PM de-energizes once freeze begins, check for 115VAC at CB K1 #4 (R) to neutral (W). If 115VAC is not present, replace CB. If 115VAC is present and PM is de-energized, check PM capacitor and motor winding continuity.
- e) **FM and LLV Diagnosis:** If FM or LLV does not energize, check for 115VAC at CB K1 #3 (BK) to neutral (W). If 115VAC is not present and LED 2 is on, check for 115VAC at CB K1 #1 (V). If 115VAC is present at #1 (V) and not at #3 (BK), replace CB. If 115VAC is present and LED 2 is on:
 For FM, check capacitor, motor winding, and blade for binding.
 For LLV, check coil voltage and continuity.
 Note: LED 2 is on for LLV/FM and off for HGV.
- f) **Refrigerant Pressures, HM, and TXV Diagnosis:** If evaporator is still not cooling, check refrigerant pressures. See "VIII.A. Specification and Performance Data Sheets."
 Next, check HM operation. If refrigeration pressures are above HM setpoint and HM is bypassing, replace HM. Check TXV for proper operation. Remove TXV bulb and hold it in your hand, refrigerant low-side pressure should rise, place TXV bulb in ice water, refrigerant low-side pressure should drop. A 10 to 15 pound pressure swing between warm and cold conditions indicate a good TXV. If a 10 to 15 pound swing is not present, replace TXV.
- g) **WRV Diagnosis:** WRV is factory set and generally no adjustment is required. If WRV fails to open in freeze, check for proper refrigerant pressures. See "VIII.A. Specification and Performance Data Sheets." If refrigerant pressures are correct and WRV does not open, adjust or replace as needed. See "IV.C. Water Regulating Valve Adjustment (water-cooled models)."

h) **Freeze Termination Diagnosis:** After 5 min. in freeze, disconnect CB K5 FS connector. 15 sec. later appliance should switch out of the freeze cycle (15 second delay after FS opens before terminating the freeze cycle). If appliance remains in freeze longer than 15 sec. after FS removed, replace CB. If appliance switches with FS removed but would previously not switch out of freeze with FS connected (long freeze - 3 beep alarm), see "II.E. Float Switch Check and Cleaning."

Note: Normal freeze cycle will last 20 to 40 min. depending on model and conditions. Cycle times and pressures should follow performance data provided in this manual. See "VIII.A. Specification and Performance Data Sheets."

i) **Short Freeze Cycle Diagnosis:** Confirm water tank fills and overflows during 1 min. fill and harvest cycles. If not, check water supply filters, shut-off valve, WV screen. If water tank empties before 5 min. timer terminates and freeze cycle is short, check that DV is not leaking by (water flowing down the drain). If DV is leaking by, remove and clean DV, replace if necessary. If water tank is full, see "II.E. Float Switch Check and Cleaning." for erratic operating FS.

7) **Pump-Out Cycle – LEDs 1, 3, and 5 are on (10/20 second pump-out).** Timing of the first pump-out is determined by S4 dip switch 5. See the table below.

Control Board Settings		
S4 Dip Switch Setting	Pump-Out Frequency	Control Board
No. 5		
OFF	Every 10 cycles	After 11th freeze cycle
ON	Every cycle	After 2nd freeze cycle

Comp and FMR continue, HGV energizes.

Note: If S4 dip switch 3 & 4 are set to 3 off and 4 on, LED 4 turns on and WV energizes.

NOTICE! S5 dip switch 1 must not be adjusted. This is the pump-out circulation selection and allows DV to energize in pump-out.

FM and LLV de-energize. PM stops for 2 sec., then PM and DV energize for 10/20 sec. depending on pump-out timer (S4 dip switch 3 & 4) setting. When the pump-out timer terminates, pump-out is complete. The pump-out frequency control (S4 dip switch 5) is factory set, and generally no adjustment is required. However, the pump-out frequency control can be set to have a pump-out occur every 10 cycles or every cycle. For details, see "III.C.4. Pump-Out Frequency Control (S4 dip switch 5)."

Pump-Out Diagnosis: In the freeze cycle before pump-out (see table above), after 5 min. of freeze disconnect CB black K5 connector (FS connector). Check that PM stops and re-starts. Next, check that PM and DV energized (water flowing down the drain through DV). If PM does not stop and re-start, check that CB LEDs 1, 3, and 5 are on. If not, replace CB. If LEDs 1, 3, and 5 are on and PM does not energize, check for 115VAC at CB K1 #4 (R) to neutral (W). If 115VAC is not present, replace CB. If not, check PM motor windings and impeller for binding. If energized, make sure DV energized. If not, check for 115VAC at CB K1 #5 (W/BU). If 115VAC is not present and LED 5 is on, replace CB. If 115VAC is present, check DV solenoid continuity. Replace as needed. If DV is energized and open, check that the drain line is not clogged.

Confirm FM and LLV de-energize. If FM or LLV are energized with LEDs 1, 3, and 5 on, replace CB.

- 8) **Normal Harvest Cycle** – Same as the initial harvest cycle. Return to step 5a) above.
Note: Appliance continues to cycle until BC is satisfied or power is switched off.
The appliance always restarts at the 1-min. fill cycle.

b) Shutdown Diagnosis

- 1) See "II.D.1a. Ultrasonic Bin Control Check."

Legend: **CB**–control board; **Comp**–compressor; **CR**–compressor relay;
CT–control transformer; **DV**–drain valve; **FM**–fan motor; **FMR**–fan motor remote;
FS–float switch; **HGV**–hot gas valve; **HM**–headmaster (C.P.R.); **HPS**–high-pressure
switch; **LLV**–liquid line valve; **PM**–pump motor; **TXV**–thermostatic expansion valve;
UBC–ultrasonic bin control; **WRV**–water regulating Valve; **WV**–inlet water valve

2. K Control Board (2A8242-02) with Mechanical Bin Control

Model	Auxiliary Code Break
KM-350MAJ	L19077K to L19236K
KM-520MAJ	L02153K to L02411K
KM-660MAJ	L05262K to L05441K
KM-660MWJ	L00674K to L00693K

WARNING

- The appliance should be diagnosed and repaired only by qualified service personnel to reduce the risk of death, electric shock, serious injury, or fire.
- Risk of electric shock. Control switch in "OFF" position does not de-energize all loads Use extreme caution and exercise safe electrical practices.
- Moving parts (e.g., fan blade) can crush and cut. Keep hands clear.
- Before servicing the appliance, move the control switch to the "OFF" position and turn off the power supply.
- **CHOKING HAZARD:** Ensure all components, fasteners, and thumbscrews are securely in place after the appliance is serviced. Make sure that none have fallen into the dispenser unit/ice storage bin.
- Make sure all food zones in the appliance and dispenser unit/ice storage bin are clean after service.

The diagnostic procedure is a sequence check that allows you to diagnose the electrical system and components. Before proceeding, check for correct installation, proper voltage per nameplate, and adequate water supply. Check CB using the steps in "II.C. Control Board Check." Check dip switch settings to assure that S4 dip switches and S5 dip switches 1 through 5 are in the factory default position. S4 dip switch 1, 2, 3, 4, and 5 are cleaning adjustments and the settings are flexible. For factory default settings, see "III.C.1. Default Dip Switch Settings."

Note: • When checking high voltage (115VAC), always choose a white (W) neutral wire to establish a good neutral connection.

- When checking voltage from the CB K1 connector (10 pin connector), pull CB K1 connector out slightly to allow room for multimeter test leads contact.

- 1) Turn off the power supply, then access the control box. Move the control switch to the "OFF" position. Clear ice from MBC.
- 2) Check that the MBC is closed and the 115VAC 10A fuse is good.

a) Sequence and Component Diagnosis

3) **Power On:** Turn on the power supply, then move the control switch to the "ON" position and the mode switch to the "ICE" position. A 5-sec. delay occurs. CB red "POWER OK" LED turns on. If CB yellow "BC OPEN/CLOSED" LED is on (indicating a full bin), move ice away from MBC.

Note: • CB red "POWER OK" LED remains on unless the 10.5VAC power supply is interrupted (K2 connector).

- Check CB using the steps in "II.C. Control Board Check" or MBC using steps in "II.D.2a. Mechanical Bin Control Check."

a) **Power On Diagnosis:** If CB red "POWER OK" LED is off, confirm 10A fuse is good. Check for 115VAC at control switch #2 (BK) to neutral (W) then at control switch #1 (P) to neutral (W). If 115VAC is present on #2 (BK) and not on #1 (P), replace control switch. If 115VAC is present on control switch #1 (P), check for 115VAC at HPS (P) to neutral (W) then HPS (BK) to neutral (W). If 115VAC is present at HPS (P) and not at HPS (BK), HPS is open. See HPS Diagnosis below. If 115VAC is present at HPS (BK), check for 10.5VAC at CB K2 #1 red wire to CB K2 #2 red wire. If 10.5VAC is not present, check CT continuity. If open, replace CT.

b) **HPS Diagnosis:** Check that the condenser coil is not clogged or restricted. Let refrigeration circuit pressures equalize. If HPS does not reset and pressures are equalized, replace HPS. If pressures are not equalized, reclaim refrigerant and diagnose refrigeration circuit restriction. Check that there are no restrictions in the refrigeration circuit.
Harvest Cycle: HGCV, strainer, or check valve.
Freeze Cycle: FM, FMR, TXV, WRV, HM, LLV, strainer, check valve, drier, and damaged line set or fitting.

Confirm that the location meets installation requirements:

- The appliance is not intended for outdoor use. Normal operating ambient temperature should be within 45°F to 100°F (7°C to 38°C).
- Allow 6" (15 cm) clearance at rear, sides, and top for proper air circulation and ease of maintenance and/or service should they be required.
- The appliance should not be located in a corrosive environment.

4) **1-Min. Fill Cycle – LED 4 is on.** WV energizes. After 1 min., CB checks for a closed FS. If FS is closed, the harvest cycle begins. If harvest cycle begins (Comp, HGV, FMR energized), continue to step 5a. If FS is open, fill cycle continues until FS closes (low water safety protection during initial start up and at the end of each harvest).

Diagnosis: Check that water enters the water tank. If not, check that the water supply line shut-off valve is open and screens or external filters are clear. Check for 115VAC at CB K1 #6 (O) to neutral (W). If 115VAC is not present, replace CB. If 115VAC is present, and WV does not energize, check for 115VAC at WV. If 115VAC is present, check coil continuity. If open, replace WV. If the water tank fills, but the appliance fails to start harvest (Comp energized), check for open FS. See "II.E. Float Switch Check and Cleaning." If FS is closed and CB fails to start the harvest cycle after 1 min., replace CB.

5a) **Initial Harvest Cycle – LEDs 1 and 4 are on.** WV continues. Comp, FMR, and HGV energize. CB monitors the warming of the evaporator via the thermistor located on the suction line. When the thermistor reaches 48°F (9°C), CB reads 3.9 kΩ from the thermistor and turns harvest termination over to the harvest timer (S4 dip switch 1 & 2 and S5 dip switch 4). WV are energized during harvest for a maximum of 6 min. or the length of harvest minus HPT setting (S4 dip switch 6), whichever is shorter. See step 5b below.

a) **Comp Diagnosis:** Check that evaporator is warming. If not, confirm that Comp energizes. If not, check for 115VAC at CB K1 #9 (Y) to neutral (W). If 115VAC is not present, check for 115VAC at CB K1 #10 (BK) to neutral (W). If 115VAC is present at #10 (BK) and not at #9 (Y), replace CB. If 115VAC is present, check for 115VAC at mode switch #2 (Y) to neutral and mode switch #1 (V) to neutral. If 115VAC is present at #2 (Y) and not at #1 (V), confirm mode switch is in "ICE" position. If in "ICE" position, check mode switch continuity. If open, replace mode switch. If 115VAC is present at mode switch #1 (V), check for 115VAC at CR solenoid. If 115VAC is present, confirm contacts are closed. If not, replace CR. If CR contacts are closed, check Comp external overload, Comp start and run capacitors, Comp start relay, and Comp motor winding.

b) **HGV Diagnosis:** If Comp is energized and evaporator is not warming, check that HGV energizes and opens. Check for 115VAC at CB K1 #2 (P) to neutral (W). If 115VAC is not present, check for 115VAC at CB K1 #1 (V). If 115VAC is not present, check wiring for loose connection from CB 10 pin connector pin #1 (V) to mode switch. If 115VAC is present on #1 (V) and not at #2 (P), replace CB. If 115VAC is present at #2 (P), check for 115VAC at HGV coil and check HGV coil continuity. Replace as needed.

c) **LLV Diagnosis:** Confirm that LLV is de-energized and closed (not bypassing). If energized, replace CB. If de-energized and bypassing, replace LLV.

d) **WRV Diagnosis:** Confirm WRV is not leaking by. If WRV is leaking by, confirm HGV is open and LLV is closed. Next, check for proper refrigerant pressures. If refrigerant pressures are correct, adjust or replace WRV. See "IV.C. Water Regulating Valve Adjustment (water-cooled models)."

5b) **Harvest Pump Time (Harvest Assist) – LEDs 1 and 3 are on.** When the thermistor reaches 48°F (9°C), CB reads 3.9 kΩ from the thermistor and turns harvest termination over to the harvest timer (S4 dip switch 1 & 2 and S5 dip switch 4). When WV de-energizes, LED 4 turns off and LED 3 turns on. PM energizes. Comp, FMR, and HGV continue.

Diagnosis: Place a thermometer on the suction line next to the thermistor. Has it warmed to 48°F (9°C) or warmer? Confirm thermistor status. See "II.F. Thermistor Check." If the thermistor reading is in proper range, dip switch 7 is on, and PM does not energize before harvest terminates, replace CB. If WV continues, check for 115VAC at CB K1 #6 (O). If 115VAC is present, and LED 4 is off, replace CB. If LED 3 is on and PM is not energized, check for 115VAC at CB K1 #4 (R). If 115VAC is not present, replace CB. If 115VAC is present and PM is not energized, check PM capacitor and motor winding continuity.

5c) **Initial Harvest Cycle Termination Diagnosis:** When the thermistor reaches 48°F (9°C), CB reads 3.9 kΩ from the thermistor and turns harvest termination over to the harvest timer (S4 dip switch 1 & 2 and S5 dip switch 4). Check discharge line temperature. For a thermistor check, see "II.F. Thermistor Check." If 1-min. fill cycle starts after harvest timer terminates, check that FS is clean and operating properly, see "II.E. Float Switch Check and Cleaning." If FS is closed, CB proceeds to the next cycle. If not, replace CB.

Note: The minimum total time allowed by CB for a complete harvest cycle is based on S5 dip switch 4. Maximum harvest time allowed is 20 min.

NOTICE! S4 dip switch 7 must remain on. Otherwise, PM will not energize during the last seconds of harvest.

6) **Freeze Cycle – LED 1, 2, and 3 are on.** Comp, FMR, and PM continue. FM and LLV energize. HGV de-energizes. Appliance is held in freeze by a 5-min. short cycle protection timer. After 5-min. short cycle protection timer terminates and FS opens, freeze cycle terminates.

Note: PM power supply continues from CB K1 #4 (R) in harvest and in freeze.

Anti-Slush: When anti-slush is enabled (S5 dip switch 5 "ON"), PM de-energizes when thermistor reaches 36°F (2.2°C) (5.8 kΩ) for 10 sec. then, energizes for the remainder of the freeze cycle.

a) **Freeze Cycle Diagnosis:** Confirm Comp, FMR, and PM continue. Confirm that FM and LLV energize. Confirm WRV opens. Next, confirm HGV de-energizes. During the first 5 min. of freeze, confirm evaporator is cooling. If not, confirm WV de-energized (not leaking by), HGV de-energized (not bypassing), LLV and FM energize, TXV and HM operate correctly, WRV opens, Comp is efficient, and refrigerant charge is correct. See "VIII.A. Specification and Performance Data Sheets."

- b) **Comp and FMR Diagnosis:** If Comp and FMR de-energize once freeze begins, check that appliance has not shut off on HPS (CB "POWER OK" LED off). If so, check "3)b HPS Diagnosis" above. If CB "POWER OK" LED is on, check for 115VAC at CB K1 #9 (Y) to neutral (W). If 115VAC is not present and LED 1 is on, replace CB. If 115VAC is present, check for 115VAC at CR coil. If 115VAC is present, check CR coil and contact continuity. Replace as needed. If CR is okay, check Comp start relay and start and run capacitors. Next, check Comp motor winding continuity. If Comp is energized but evaporator is not cooling, check for an inefficient Comp. See "VIII.A. Specification and Performance Data Sheets." If Comp is energized but FMR is not, check for 115VAC at the FMR junction box. If 115VAC is not present, check icemaker wiring connections. If 115VAC is present, check for voltage at condenser unit. If 115VAC is not present, check field wiring connections. If 115VAC is present, check FMR capacitor, motor winding, and fan blade for binding.
- c) **WV and HGV Diagnosis:** If WV is energized, check for 115VAC at CB K1 #6 (O) to neutral (W). If 115VAC is present after PM energizes in harvest cycle, replace CB. If 115VAC is not present, replace WV (bypassing). If HGV did not de-energize at the end of harvest, check for 115VAC at CB K1 #2 (P) to neutral (W). If 115VAC is present and LED 2 is on, replace CB. If 115VAC is not present, replace HGV (bypassing).
- d) **PM Diagnosis:** Confirm water is flowing over evaporator from PM and not WV. If PM de-energizes once freeze begins, check for 115VAC at CB K1 #4 (R) to neutral (W). If 115VAC is not present, replace CB. If 115VAC is present and PM is de-energized, check PM capacitor and motor winding continuity.
- e) **FM and LLV Diagnosis:** If FM or LLV does not energize, check for 115VAC at CB K1 #3 (BK) to neutral (W). If 115VAC is not present and LED 2 is on, check for 115VAC at CB K1 #1 (V). If 115VAC is present at #1 (V) and not at #3 (BK), replace CB. If 115VAC is present and LED 2 is on:
 For FM, check capacitor, motor winding, and blade for binding.
 For LLV, check coil voltage and continuity.
 Note: LED 2 is on for LLV/FM and off for HGV.
- f) **Refrigerant Pressures, HM, and TXV Diagnosis:** If evaporator is still not cooling, check refrigerant pressures. See "VIII.A. Specification and Performance Data Sheets."
 Next, check HM operation. If refrigeration pressures are above HM setpoint and HM is bypassing, replace HM. Check TXV for proper operation. Remove TXV bulb and hold it in your hand, refrigerant low-side pressure should rise, place TXV bulb in ice water, refrigerant low-side pressure should drop. A 10 to 15 pound pressure swing between warm and cold conditions indicate a good TXV. If a 10 to 15 pound swing is not present, replace TXV.
- g) **WRV Diagnosis:** WRV is factory set and generally no adjustment is required. If WRV fails to open in freeze, check for proper refrigerant pressures. See "VIII.A. Specification and Performance Data Sheets." If refrigerant pressures are correct and WRV does not open, adjust or replace as needed. See "IV.C. Water Regulating Valve Adjustment (water-cooled models)."

h) **Freeze Termination Diagnosis:** After 5 min. in freeze, disconnect CB K5 FS connector. 15 sec. later appliance should switch out of the freeze cycle (15 second delay after FS opens before terminating the freeze cycle). If appliance remains in freeze longer than 15 sec. after FS removed, replace CB. If appliance switches with FS removed but would previously not switch out of freeze with FS connected (long freeze - 3 beep alarm), see "II.E. Float Switch Check and Cleaning."

Note: Normal freeze cycle will last 20 to 40 min. depending on model and conditions. Cycle times and pressures should follow performance data provided in this manual. See "VIII.A. Specification and Performance Data Sheets."

i) **Short Freeze Cycle Diagnosis:** Confirm water tank fills and overflows during 1 min. fill and harvest cycles. If not, check water supply filters, shut-off valve, WV screen. If water tank empties before 5 min. timer terminates and freeze cycle is short, check that DV is not leaking by (water flowing down the drain). If DV is leaking by, remove and clean DV, replace if necessary. If water tank is full, see "II.E. Float Switch Check and Cleaning." for erratic operating FS.

7) **Pump-Out Cycle – LEDs 1, 3, and 5 are on (10/20 second pump-out).** Timing of the first pump-out is determined by S4 dip switch 5. See the table below.

Control Board Settings		
S4 Dip Switch Setting	Pump-Out Frequency	Control Board
No. 5		
OFF	Every 10 cycles	After 11th freeze cycle
ON	Every cycle	After 2nd freeze cycle

Comp and FMR continue, HGV energizes.

Note: If S4 dip switch 3 & 4 are set to 3 off and 4 on, LED 4 turns on and WV energizes.

NOTICE! S5 dip switch 1 must not be adjusted. This is the pump-out circulation selection and allows DV to energize in pump-out.

FM and LLV de-energize. PM stops for 2 sec., then PM and DV energize for 10/20 sec. depending on pump-out timer (S4 dip switch 3 & 4) setting. When the pump-out timer terminates, pump-out is complete. The pump-out frequency control (S4 dip switch 5) is factory set, and generally no adjustment is required. However, the pump-out frequency control can be set to have a pump-out occur every 10 cycles or every cycle. For details, see "III.C.4. Pump-Out Frequency Control (S4 dip switch 5)."

Pump-Out Diagnosis: In the freeze cycle before pump-out (see table above), after 5 min. of freeze disconnect CB black K5 connector (FS connector). Check that PM stops and re-starts. Next, check that PM and DV energized (water flowing down the drain through DV). If PM does not stop and re-start, check that CB LEDs 1, 3, and 5 are on. If not, replace CB. If LEDs 1, 3, and 5 are on and PM does not energize, check for 115VAC at CB K1 #4 (R) to neutral (W). If 115VAC is not present, replace CB. If not, check PM motor windings and impeller for binding. If energized, make sure DV energized. If not, check for 115VAC at CB K1 #5 (W/BU). If 115VAC is not present and LED 5 is on, replace CB. If 115VAC is present, check DV solenoid continuity. Replace as needed. If DV is energized and open, check that the drain line is not clogged.

Confirm FM and LLV de-energize. If FM or LLV are energized with LEDs 1, 3, and 5 on, replace CB.

- 8) **Normal Harvest Cycle** – Same as the initial harvest cycle. Return to step 5a) above.
Note: Appliance continues to cycle until BC is satisfied or power is switched off.
The appliance always restarts at the 1-min. fill cycle.

2. Shutdown Diagnosis

- 1) See "II.D.2a. Mechanical Bin Control Check."

Legend: **MBC**–bin control; **CB**–control board; **Comp**–compressor; **CR**–compressor relay; **CT**–control transformer; **DV**–drain valve; **FM**–fan motor; **FMR**–fan motor remote; **FS**–float switch; **HGV**–hot gas valve; **HM**–headmaster (C.P.R.); **HPS**–high-pressure switch; **LLV**–liquid line valve; **PM**–pump motor; **TXV**–thermostatic expansion valve; **WRV**–water regulating Valve; **WV**–inlet water valve

3. K+ Control Board (2A9678-01) with Ultrasonic Bin Control

Model	Auxiliary Code Break
KM-350MAJ	L19237K and later
KM-350MWJ	L20794L and later
KM-420M_J(Z)	All
KM-520MAJ	L02412K and later
KM-520MWJ	L10989L and later
KM-520MRJZ	All
KM-660MAJ	L15442L and later
KM-660MWJ	L10694L and later
KM-660MRJZ	All

WARNING

- The appliance should be diagnosed and repaired only by qualified service personnel to reduce the risk of death, electric shock, serious injury, or fire.
- Risk of electric shock. Control switch in "OFF" position does not de-energize all loads Use extreme caution and exercise safe electrical practices.
- Moving parts (e.g., fan blade) can crush and cut. Keep hands clear.
- Before servicing the appliance, move the control switch to the "OFF" position and turn off the power supply.
- **CHOKING HAZARD:** Ensure all components, fasteners, and thumbscrews are securely in place after the appliance is serviced. Make sure that none have fallen into the dispenser unit/ice storage bin.
- Make sure all food zones in the appliance and dispenser unit/ice storage bin are clean after service.

The diagnostic procedure is a sequence check that allows you to diagnose the electrical system and components. Before proceeding, check for correct installation, proper voltage per nameplate, and adequate water supply. Check CB using the steps in "II.C. Control Board Check." Check dip switch settings to assure that S4 dip switches and S5 dip switches 1 through 5 are in the factory default position. S4 dip switch 1, 2, 3, 4, and 5 are cleaning adjustments and the settings are flexible. For factory default settings, see "III.C.1. Default Dip Switch Settings."

Note: • When checking high voltage (115VAC), always choose a white (W) neutral wire to establish a good neutral connection.

- When checking voltage from the CB K1 connector (10 pin connector), pull CB K1 connector out slightly to allow room for multimeter test leads contact.

- 1) Turn off the power supply, then access the control box. Move the control switch to the "OFF" position. Clear ice from UBC sensing area.
- 2) Check that the 115VAC 10A fuse is good.

a) Sequence and Component Diagnosis

- 3) **Power On:** Turn on the power supply, then move the control switch to the "ON" position and the mode switch to the "ICE" position. A 5-sec. delay occurs. CB red "POWER OK" LED turns on. If CB yellow "BC OPEN/CLOSED" LED is on, see "II.D.1a. Ultrasonic Bin Control Check."

Note: • CB red "POWER OK" LED remains on unless the 10.5VAC power supply is interrupted (K2 connector).

- Check CB using the steps in "II.C. Control Board Check." or UBC using steps in "II.D.1a. Ultrasonic Bin Control Check."

- a) **Power On Diagnosis:** If CB red "POWER OK" LED is off, confirm 10A fuse is good. Check for 115VAC at control switch #2 (BK) to neutral (W) then at control switch #1 (P) to neutral (W). If 115VAC is present on #2 (BK) and not on #1 (P), replace control switch. If 115VAC is present on control switch #1 (P), check for 115VAC at HPS (P) to neutral (W) then HPS (BK) to neutral (W). If 115VAC is present at HPS (P) and not at HPS (BK), HPS is open. See HPS Diagnosis below. If 115VAC is present at HPS (BK), check for 10.5VAC at CB K2 #1 red wire to CB K2 #2 red wire. If 10.5VAC is not present, check CT continuity. If open, replace CT.

- b) **Power On Ultrasonic Bin Control Diagnosis:** If CB red "POWER OK" LED and CB "BC OPEN/CLOSED" LED are on, clear UBC sensing area. If no object is in the area, replace UBC. If CB red "POWER OK" LED is on and CB "BC OPEN/CLOSED" LED is off, see "II.D.1a. Ultrasonic Bin Control Check."

Note: UCB control board delay time:

Sensing Ice: CB "BC OPEN/CLOSED" LED turns on.

Not Sensing Ice: CB "BC OPEN/CLOSED" LED turns off after 30-sec. delay.

- b) **HPS Diagnosis:** Check that the condenser coil is not clogged or restricted. Allow the refrigeration circuit pressures to equalize. If HPS does not reset and pressures are equalized, replace HPS. If pressures are not equalized, reclaim refrigerant and diagnose refrigeration circuit restriction. Check that there are no restrictions in the refrigeration circuit.
Harvest Cycle: HGV, strainer, or check valve.
Freeze Cycle: FM, FMR, TXV, WRV, HM, LLV, strainer, check valve, drier, and damaged line set or fitting.

Confirm that the location meets installation requirements:

- The appliance is not intended for outdoor use. Normal operating ambient temperature should be within 45°F to 100°F (7°C to 38°C).
- Allow 6" (15 cm) clearance at rear, sides, and top for proper air circulation and ease of maintenance and/or service should they be required.
- The appliance should not be located in a corrosive environment.

- 4) **1-Min. Fill Cycle – WV LED is on.** WV energizes. After 1 min., CB checks for a closed FS. If FS is closed, the harvest cycle begins. If harvest cycle begins (Comp, HGV, FMR energized), continue to step 5a. If FS is open, fill cycle continues until FS closes (low water safety protection during initial start up and at the end of each harvest).
Diagnosis: Check that water enters the water tank. If not, check that the water supply line shut-off valve is open and screens or external filters are clear. Check for 115VAC at CB K1 #6 (O) to neutral (W). If 115VAC is not present, replace CB. If 115VAC is present, and WV does not energize, check for 115VAC at WV. If 115VAC is present, check coil continuity. If open, replace WV. If the water tank fills, but the appliance fails to start harvest (Comp energized), check for open FS. See "II.E. Float Switch Check and Cleaning." If FS is closed and CB fails to start the harvest cycle after 1 min., replace CB.
- 5a) **Initial Harvest Cycle – Comp, WV, and FM/HGV LEDs are on.** WV continues. Comp, FMR, and HGV energize. CB monitors the warming of the evaporator via the thermistor located on the suction line. When the thermistor reaches 48°F (9°C), CB reads 3.9 kΩ from the thermistor and turns harvest termination over to the harvest timer (S4 dip switch 1 & 2 and S5 dip switch 4). WV is energized during harvest for a maximum of 6 min. or the length of harvest minus HPT setting (S4 dip switch 6), whichever is shorter. See step 5b below.
- a) **Comp Diagnosis:** Check that evaporator is warming. If not, confirm that Comp energizes. If not, check for 115VAC at CB K1 #9 (Y) to neutral (W). If 115VAC is not present, check for 115VAC at CB K1 #10 (BK) to neutral (W). If 115VAC is present at #10 (BK) and not at #9 (Y), replace CB. If 115VAC is present, check for 115VAC at mode switch #2 (Y) to neutral and mode switch #1 (V) to neutral. If 115VAC is present at #2 (Y) and not at #1 (V), confirm mode switch is in "ICE" position. If in "ICE" position, check mode switch continuity. If open, replace mode switch. If 115VAC is present at mode switch #1 (V), check for 115VAC at CR solenoid. If 115VAC is present, confirm contacts are closed. If not, replace CR. If CR contacts are closed, check Comp external overload, Comp start and run capacitors, Comp start relay, and Comp motor winding.
- b) **HGV Diagnosis:** If Comp is energized and evaporator is not warming, check that HGV energizes and opens. Check for 115VAC at CB K1 #2 (P) to neutral (W). If 115VAC is not present, check for 115VAC at CB K1 #1 (V). If 115VAC is not present, check wiring for loose connection from CB 10 pin connector pin #1 (V) to mode switch. If 115VAC is present on #1 (V) and not at #2 (P), replace CB. If 115VAC is present at #2 (P), check for 115VAC at HGV coil and check HGV coil continuity. Replace as needed.
- c) **LLV Diagnosis:** Confirm that LLV is de-energized and closed (not bypassing). If energized, replace CB. If de-energized and bypassing, replace LLV.
- d) **WRV Diagnosis:** Confirm WRV is not leaking by. If WRV is leaking by, confirm HGV is open and LLV is closed. Next, check for proper refrigerant pressures. If refrigerant pressures are correct, adjust or replace WRV. See "IV.C. Water Regulating Valve Adjustment (water-cooled models)."

5b) Harvest Pump Time (Harvest Assist) – Comp, PM, and FM/HGV LEDs are on.

When the thermistor reaches 48°F (9°C), CB reads 3.9 kΩ from the thermistor and turns harvest termination over to the harvest timer (S4 dip switch 1 & 2 and S5 dip switch 4). When WV de-energizes, WV LED turns off and PM LED turns on. PM energizes. Comp, FMR, and HGV continue.

Diagnosis: Place a thermometer on the suction line next to the thermistor. Has it warmed to 48°F (9°C) or warmer? Confirm thermistor status. See "II.F. Thermistor Check." If the thermistor reading is in proper range, dip switch 7 is on, and PM does not energize before harvest terminates, replace CB. If WV continues, check for 115VAC at CB K1 #6 (O). If 115VAC is present, and WV LED is off, replace CB. If PM LED is on and PM is not energized, check for 115VAC at CB K1 #4 (R). If 115VAC is not present, replace CB. If 115VAC is present and PM is not energized, check PM capacitor and motor winding continuity.

5c) Initial Harvest Cycle Termination Diagnosis: When the thermistor reaches 48°F (9°C), CB reads 3.9 kΩ from the thermistor and turns harvest termination over to the harvest timer (S4 dip switch 1 & 2 and S5 dip switch 4). Check discharge line temperature. For a thermistor check, see "II.F. Thermistor Check." If 1-min. fill cycle starts after harvest timer terminates, check that FS is clean and operating properly, see "II.E. Float Switch Check and Cleaning." If FS is closed, CB proceeds to the next cycle. If not, replace CB.

Note: The minimum total time allowed by CB for a complete harvest cycle is based on S5 dip switch 4. Maximum harvest time allowed is 20 min.

NOTICE! S4 dip switch 7 must remain on. Otherwise, PM will not energize during the last seconds of harvest.

6) Freeze Cycle – Comp and PM LEDs are on. Comp, FMR, and PM continue. FM and LLV energize. HGV de-energizes. Appliance is held in freeze by a 5-min. short cycle protection timer. After 5-min. short cycle protection timer terminates and FS opens, freeze cycle terminates.

Note: PM power supply continues from CB K1 #4 (R) in harvest and in freeze.

Anti-Slush: When anti-slush is enabled (S5 dip switch 5 "ON"), PM de-energizes when thermistor reaches 36°F (2.2°C) (5.8 kΩ) for 10 sec. then, energizes for the remainder of the freeze cycle.

a) Freeze Cycle Diagnosis: Confirm Comp, FMR, and PM continue. Confirm that FM and LLV energize. Confirm WRV opens. Next, confirm HGV de-energizes. During the first 5 min. of freeze, confirm evaporator is cooling. If not, confirm WV de-energized (not leaking by), HGV de-energized (not bypassing), LLV and FM energize, TXV and HM operate correctly, WRV opens, Comp is efficient, and refrigerant charge is correct. See "VIII.A. Specification and Performance Data Sheets."

- b) **Comp and FMR Diagnosis:** If Comp and FMR de-energize once freeze begins, check that appliance has not shut off on HPS (CB "POWER OK" LED off). If so, check "3)b HPS Diagnosis" above. If CB "POWER OK" LED is on, check for 115VAC at CB K1 #9 (Y) to neutral (W). If 115VAC is not present and Comp LED is on, replace CB. If 115VAC is present, check for 115VAC at CR coil. If 115VAC is present, check CR coil and contact continuity. Replace as needed. If CR is okay, check Comp start relay and start and run capacitors. Next, check Comp motor winding continuity. If Comp is energized but evaporator is not cooling, check for an inefficient Comp. See "VIII.A. Specification and Performance Data Sheets." If Comp is energized but FMR is not, check for 115VAC at the FMR junction box. If 115VAC is not present, check icemaker wiring connections. If 115VAC is present, check for voltage at condenser unit. If 115VAC is not present, check field wiring connections. If 115VAC is present, check FMR capacitor, motor winding, and fan blade for binding.
- c) **WV and HGV Diagnosis:** If WV is energized, check for 115VAC at CB K1 #6 (O) to neutral (W). If 115VAC is present after PM energizes in harvest cycle, replace CB. If 115VAC is not present, replace WV (bypassing). If HGV did not de-energize at the end of harvest, check for 115VAC at CB K1 #2 (P) to neutral (W). If 115VAC is present at CB K1 #2 (P) and FM/HGV LED is off, replace CB. If 115VAC is not present at CB K1 #2 (P), replace HGV (bypassing).
- d) **PM Diagnosis:** Confirm water is flowing over evaporator from PM and not WV. If PM de-energizes once freeze begins, check for 115VAC at CB K1 #4 (R) to neutral (W). If 115VAC is not present, replace CB. If 115VAC is present and PM is de-energized, check PM capacitor and motor winding continuity.
- e) **FM and LLV Diagnosis:** If FM or LLV does not energize, check for 115VAC at CB K1 #3 (BK) to neutral (W). If 115VAC is not present and FM/HGV LED is off, check for 115VAC at CB K1 #1 (V). If 115VAC is present at #1 (V) and not at #3 (BK), replace CB. If 115VAC is present at #3 (BK) and FM/HGV LED is off:
 For FM, check capacitor, motor winding, and blade for binding.
 For LLV, check coil voltage and continuity.
 Note: FM is OFF when FM/HGV LED is ON.
- f) **Refrigerant Pressures, HM, and TXV Diagnosis:** If evaporator is still not cooling, check refrigerant pressures. See "VIII.A. Specification and Performance Data Sheets."
 Next, check HM operation. If refrigeration pressures are above HM setpoint and HM is bypassing, replace HM. Check TXV for proper operation. Remove TXV bulb and hold it in your hand, refrigerant low-side pressure should rise, place TXV bulb in ice water, refrigerant low-side pressure should drop. A 10 to 15 pound pressure swing between warm and cold conditions indicate a good TXV. If a 10 to 15 pound swing is not present, replace TXV.
- g) **WRV Diagnosis:** WRV is factory set and generally no adjustment is required. If WRV fails to open in freeze, check for proper refrigerant pressures. See "VIII.A. Specification and Performance Data Sheets." If refrigerant pressures are correct and WRV does not open, adjust or replace as needed. See "IV.C. Water Regulating Valve Adjustment (water-cooled model)."

h) **Freeze Termination Diagnosis:** After 5 min. in freeze, disconnect CB K5 FS connector. 15 sec. later appliance should switch out of the freeze cycle (15 second delay after FS opens before terminating the freeze cycle). If appliance remains in freeze longer than 15 sec. after FS removed, replace CB. If appliance switches with FS removed but would previously not switch out of freeze with FS connected (long freeze - 3 beep alarm), see "II.E. Float Switch Check and Cleaning."

Note: Normal freeze cycle will last 20 to 40 min. depending on model and conditions. Cycle times and pressures should follow performance data provided in this manual. See "VIII.A. Specification and Performance Data Sheets."

i) **Short Freeze Cycle Diagnosis:** Confirm water tank fills and overflows during 1 min. fill and harvest cycles. If not, check water supply filters, shut-off valve, WV screen. If water tank empties before 5 min. timer terminates and freeze cycle is short, check that DV is not leaking by (water flowing down the drain). If DV is leaking by, remove and clean DV, replace if necessary. If water tank is full, see "II.E. Float Switch Check and Cleaning." for erratic operating FS.

7) **Pump-Out Cycle – Comp, PM, FM/HGV and DV LEDs are on (10/20 second pump-out).** Timing of the first pump-out is determined by S4 dip switch 5. See the table below.

Control Board Settings		
S4 Dip Switch Setting	Pump-Out Frequency	1st Pump-Out
No. 5		
OFF	Every 10 cycles	After 11th freeze cycle
ON	Every cycle	After 2nd freeze cycle

Comp and FMR continue, HGV energizes.

Note: If S4 dip switch 3 & 4 are set to 3 off and 4 on, WV LED turns on and WV energizes. **NOTICE! S5 dip switch 1 must not be adjusted. This is the pump-out circulation selection and allows DV to energize in pump-out.**

FM and LLV de-energize. PM stops for 2 sec., then PM and DV energize for 10/20 sec. depending on pump-out timer (S4 dip switch 3 & 4) setting. When the pump-out timer terminates, pump-out is complete. The pump-out frequency control (S4 dip switch 5) is factory set, and generally no adjustment is required. However, the pump-out frequency control can be set to have a pump-out occur every 10 cycles or every cycle. For details, see "III.C.4. Pump-Out Frequency Control (S4 dip switch 5)."

Pump-Out Diagnosis: In the freeze cycle before pump-out (see table above), after 5 min. of freeze disconnect CB black K5 connector (FS connector). Check that PM stops and re-starts. Next, check that PM and DV energized (water flowing down the drain through DV). If PM does not stop and re-start, check that CB Comp, PM, and DV LEDs are on. If not, replace CB. If Comp, PM, and DV LEDs are on and PM does not energize, check for 115VAC at CB K1 #4 (R) to neutral (W). If 115VAC is not present, replace CB. If not, check PM motor windings and impeller for binding. If energized, make sure DV energized. If not, check for 115VAC at CB K1 #5 (W/BU). If 115VAC is not present and DV LED is on, replace CB. If 115VAC is present, check DV solenoid continuity. Replace as needed. If DV is energized and open, check that the drain line is not clogged.

Confirm FM and LLV de-energize. If FM or LLV are energized with Comp, PM, and DV LEDs on, replace CB.

- 8) **Normal Harvest Cycle** – Same as the initial harvest cycle. Return to step 5a) above.
Note: Appliance continues to cycle until BC is satisfied or power is switched off.
The appliance always restarts at the 1-min. fill cycle.

b) Shutdown Diagnosis

- 1) See "II.D.1a. Ultrasonic Bin Control Check."

Legend: **CB**–control board; **Comp**–compressor; **CR**–compressor relay;
CT–control transformer; **CV**–cleaning valve; **DV**–drain valve;
FM–fan motor; **FMR**–fan motor remote; **FS**–float switch; **HGV**–hot gas valve;
HM–headmaster (C.P.R.); **HPS**–high-pressure switch; **HPT**–harvest pump time;
LLVs–liquid line valve; **PM**–pump motor; **TXV**–thermostatic expansion valve;
UBC–ultrasonic bin control; **WRV**–water regulating valve; **WV**–inlet water valve

C. Control Board Check

Before replacing CB that does not show a visible defect and that you suspect is bad, always conduct the following check procedure. This procedure will help you verify your diagnosis.

Alarm Reset: If CB is in alarm (beeping), press the "ALARM RESET" button on CB while CB is beeping. **WARNING! Risk of electric shock. Care should be taken not to touch live terminals.** Once reset, the icemaker starts at the 1-minute fill cycle. For audible alarm information, see "III.B. LED Lights and Audible Alarm Safeties."

- 1) Check the dip switch settings to assure that S4 dip switch 3, 4, 7, 8, 9, 10 and S5 dip switch 1 through 5 are in the factory default position. S4 dip switch 1, 2, 5, and 6 are cleaning adjustments and the settings are flexible. For factory default settings, see "III.C.1. Default Dip Switch Settings."
- 2) Move the control switch to the "ON" position and the mode switch to the "ICE" position. If the red CB "POWER OK" LED is on, control voltage is good, continue to step 3a) or 3b). If CB "POWER OK" LED is off, check CT secondary circuit. CT output is 10.5VAC at 115VAC primary input. If the secondary circuit has proper voltage and the red LED is off, replace CB.

If the secondary circuit does not have proper voltage, check CT primary circuit. Check for 115VAC at CB K1 connector pin #10 (BK) to neutral (W) for 115VAC. Always choose a white (W) neutral wire to establish a good neutral connection when checking voltages. For additional checks, see "II.1.1. No Ice Production."

- 3a) **K Control Board (2A8242-02)** - The "OUTPUT TEST" button provides a relay sequence test. Make sure the control switch is in the "ON" position and the mode switch is in the "ICE" position, then press the "OUTPUT TEST" button. For the correct lighting sequence, see the table below. Note that the order of the LEDs from the outer edge of the control board is 1, 4, 5, 3, 2. Components (e.g., compressor) cycle during the test. See Fig. 1.

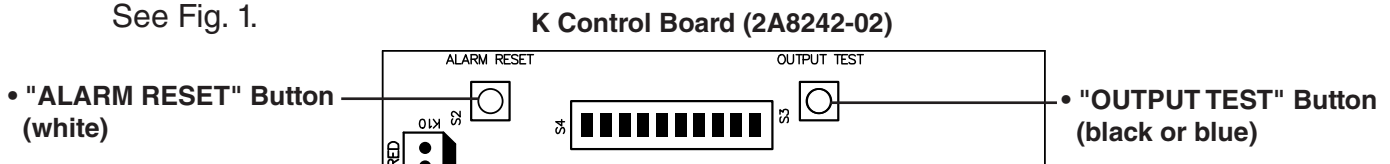

Fig. 1

- 3b) **K+ Control Board (2A9678-01)** - The "OUTPUT TEST" button provides a relay sequence test. Make sure the control switch is in the "ON" position and the mode switch is in the "ICE" position, then press the "OUTPUT TEST" button. For the correct lighting sequence, see the table below. Note that the order of the LEDs from the outer edge of the control board is Comp, CV, WV, DV, PM, FM/HGV. Components cycle during the test. See Fig. 2.

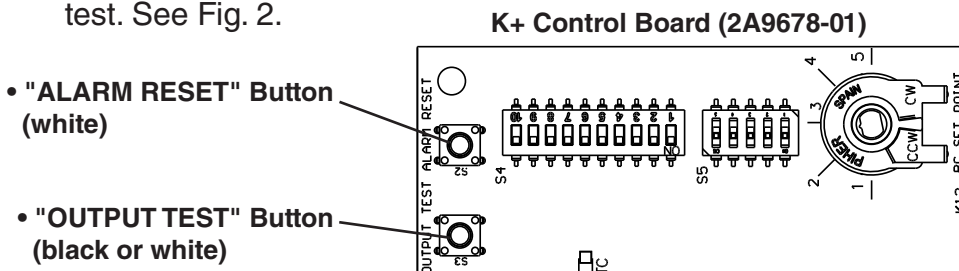

Fig. 2

Following the output test cycle, the icemaker begins normal icemaking operation at the 1-minute fill cycle. If the LEDs do not light as described above, replace CB.

IMPORTANT! Do not press the "OUTPUT TEST" button while CB is in alarm.

See Fig. 1/2. Pressing the "OUTPUT TEST" button while CB is in alarm initiates an output test and locks out the "ALARM RESET" button until power is turned off and back on.

- 4) To verify voltage output from CB to the components, slide the CB K1 connector out far enough to allow multimeter lead contact. With the icemaker in the cycle to be tested, check output voltage from the corresponding pin on CB K1 connector to a neutral (W wire). If output voltage is not found and the appropriate LED is on, replace CB.
- 5) Check CB control connectors K3, K4, K5, and K12 for correct VDC per table below. See Fig. 3 and 4.

Legend: **CB**—control board; **CT**—control transformer

K Control Board (2A8242-02)

K3 Thermistor		K4 Ultrasonic Control Board		K5 Float Switch	
Pin #	VDC	Pin #	VDC	Pin #	VDC
#1 to #2	5VDC	#1 to #2	5VDC	#1 to #2	1.2VDC
#1 to #3	5VDC	#1 to #3	5VDC	#1 to #3	2VDC
#2 to #3	0VDC	#2 to #3	0VDC	#2 to #3	1.2VDC

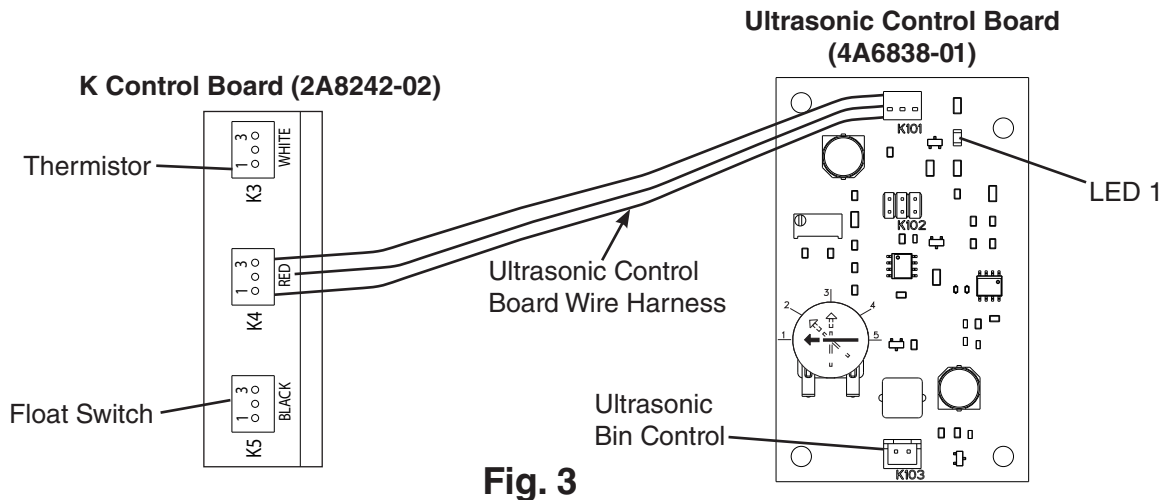

K+ Control Board (2A9678-01)

K5 Float Switch		K3 Thermistor		K12 Ultrasonic Bin Control	
Pin #	VDC	Pin #	VDC	Pin #	VDC
#1 to #2	1.2VDC	#1 to #2	5VDC	#1 to #2	TBD
#1 to #3	2VDC	#1 to #3	5VDC	#1 to #3	TBD
#2 to #3	1.2VDC	#2 to #3	0VDC	#2 to #3	TBD

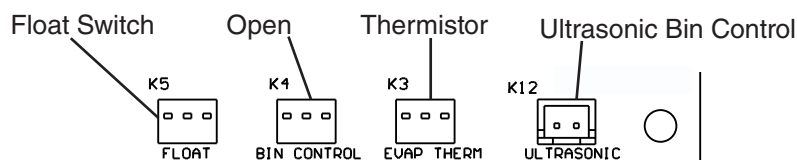

D. Bin Control Check, Adjustment, and Cleaning

⚠ WARNING

- All parts are factory-adjusted. Improper adjustments may adversely affect safety, performance, component life, and warranty coverage.
- In Hoshizaki DB and DM dispenser applications, the bin control controller setting must be adjusted to 2. For Coca-Cola Freestyle® Dispenser and other dispenser applications, the bin control controller setting must be adjusted to 3. Increasing the ice level on any dispenser application could lead to icemaker movement, water leakage, or ice overflow.
- Be sure control switch is in "OFF" position and components (fan blade) have stopped moving before attempting to remove or replace the ultra sonic bin control sensor.

NOTICE

- Do not block the bin control lens with top kits or the icemaker will not operate properly.
- Failure to properly adjust the bin control setting could result in water leakage, ice backup, and icemaker damage.

1a. Ultrasonic Bin Control Check

Before replacing UBC sensor and CB(s) that does not show a visible defect and you suspect is bad, always conduct the following check procedure. This procedure will help you verify your diagnosis. Note: It is strongly advised to keep a known "good" UBC sensor on your truck, for troubleshooting assistance.

The ultrasonic bin control is factory set for use on Hoshizaki America standard ice storage bins. If mounted on a dispenser application or if a change to the ice level in an ice storage bin application is desired, see "II.D.1b. Ultrasonic Bin Control Adjustment."

- 1) Remove the front panel. Move the control switch to the "OFF" position, then remove right side panel, and base cover. See Fig. 5.
- 2) Clear ice away from UBC area and confirm that the UBC lens is clean.
- 3) Place the mode switch in the "ICE" position, then move the control switch to the "ON" position. See Fig. 6.

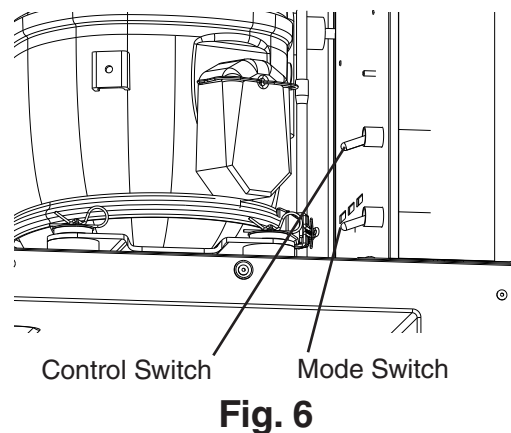
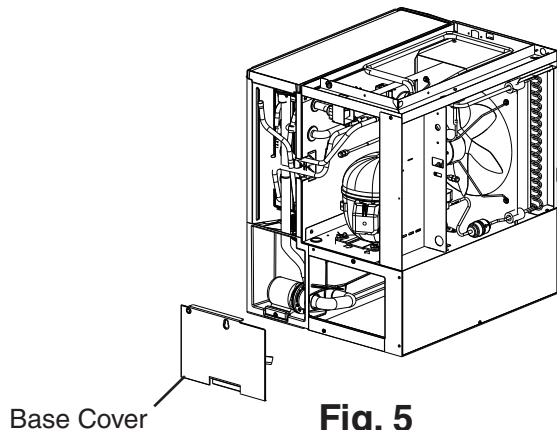

4a) **K Control Board (2A8242-02)** - UBC control board green "LED 1" LED is on and CB yellow "BC OPEN/CLOSED" LED is off.

a) **Bin Empty Diagnosis:** If fill cycle does not start, confirm UBC control board green "LED 1" LED is on. If not, with UBC wire harness connected to CB K4 connector, check for 5VDC at CB K4 pin #3 (W) to CB K4 pin #2 (BK). If 5VDC is not present, replace CB. If 5VDC is present, check that the UBC wire harness is connected to the UBC control board. If the UBC control board green "LED 1" LED is off, replace UBC and UBC control board. If UBC control board green "LED 1" LED is on and icemaker does not start, check for 1VDC at CB K4 pin #1 (R) to CB K4 pin #2 (BK). If 1VDC is present, replace CB. If 4VDC is present, confirm no object is obstructing UBC lens. If no obstruction, replace UBC and UBC control board.

Control Board K4 Bin Control Connector		
Bin Empty (closed)		
Pin #	Wire Color	VDC
#1 to #2	R to BK	1VDC
#1 to #3	R to W	5VDC
#2 to #3	BK to W	5VDC

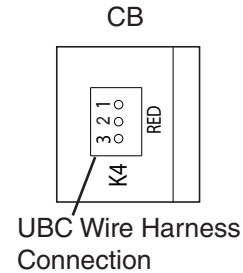

b) As water begins to fill the water tank (1-min. fill), place an object 5" to 7" (127 to 178 mm) away from the UBC lens. See Fig. 7a.

UBC control board 5-sec. delay timer starts. UBC control board 5-sec. delay timer terminates, green "LED1" LED turns off and CB "BC OPEN/CLOSED" LED turns on. CB 15-sec. delay timer starts. CB 15-sec. delay timer terminates and the icemaker shuts down. Remove the object from the UBC lens. UBC control board 30-sec. delay timer starts. UBC control board 30-sec. delay timer terminates, CB "BC OPEN/CLOSED" LED turns off, UBC control board green "LED 1" LED turns on, and the icemaker restarts. Note: In some cases, removing the UBC sensor and rotating the UBC lens up and down, provides better access when troubleshooting.

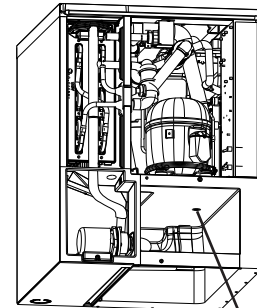

Fig. 7a Bin Control Lens

4b) **K+ Control Board (2A9678-01)** - CB yellow "BIN CLS" LED is off.

a) **Bin Empty Diagnosis:** As water begins to fill the water tank (1-min. fill), place an object 5" to 7" (127 to 178 mm) away from the UBC lens. See Fig. 7b.

CB 5-sec. delay timer starts. "BIN CLS" LED turns on. CB 5-sec. delay timer terminates, CB 15-sec. delay timer starts. CB 15-sec. delay timer terminates and the icemaker shuts down. Remove the object from the UBC lens. CB 30-sec. delay timer starts. CB 30-sec. delay timer terminates, CB "BIN CLS" LED turns off, and the icemaker restarts. Note: In some cases, removing the UBC sensor and rotating the UBC lens up and down, provides better access when troubleshooting.

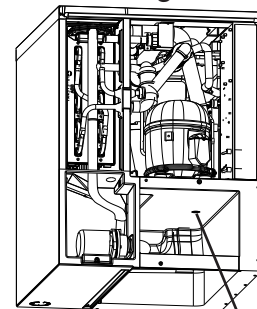

Fig. 7b Bin Control Lens

Cycle at Bin Control Activation	Control Board Shutdown
Fill Cycle	15 sec. after activation.
Harvest Cycle	If engaged 15 sec. or longer, at the end of harvest cycle.
Freeze Cycle	15 sec. after activation if activated at least 15 sec. before the 5-min. short cycle protection timer terminates. Otherwise, at the end of the next harvest cycle.

Ice Level in Bin	K Control Board (2A8242-02)		K+ Control Board (2A9678-01)
	K Control Board (2A8242-02)	Remote Ultrasonic Control Board (4A6838-01)	
	"BC OPEN/CLOSED" LED	LED 1	"BIN CLS" LED
Empty	OFF	ON	OFF
Full	ON	OFF	ON

5a) **K Control Board (2A8242-02) - Bin Full Diagnosis:** Place an object 5" to 7" (127 to 178 mm) away from the UBC sensor lens. If shut down cycle does not start, confirm UBC control board green "LED 1" LED turns off. If not, check for 4VDC at CB K4 pin #1 (R) to CB K4 pin #2 (BK). If 1VDC is present, confirm object placement. If object placement is correct, replace UBC sensor and UBC control board. If UBC control board green "LED 1" LED turns off and CB yellow "BC OPEN/CLOSED" LED does not turn on and 4VDC is present at CB K4 pin #1 (R) to CB K4 pin #2 (BK), replace CB. If CB yellow "BC OPEN/CLOSED" LED turns on and shut down cycle does not start, see "II.B.1.4) 1-min. Fill Cycle."

Control Board K4 Bin Control Connector		
Bin Full (open)		
Pin #	Wire Color	VDC
#1 to #2	R to BK	4VDC
#1 to #3	R to W	1VDC
#2 to #3	BK to W	5VDC

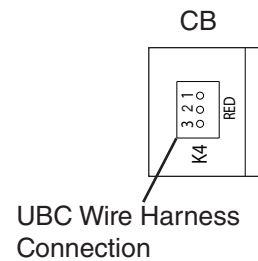

5b) **K+ Control Board (2A9678-01) - Bin Full Diagnosis:** Place an object 5" to 7" (127 to 178 mm) away from the UBC lens. See Fig. 7b. If shut down cycle does not start, confirm CB "BIN CLS" LED turns on. If not, confirm object placement. If object placement is correct, replace UBC sensor and CB. If CB yellow "BC OPEN/CLOSED" LED turns on and shut down cycle does not start, see "II.B.1.4) 1-min. Fill Cycle."
 Note: In some cases, removing the UBC sensor and rotating UBC lens up and down, provides better access when troubleshooting.

- 6) Once the icemaker restarts, move the control switch to the "OFF" position, then turn off the power supply.
- 7) Replace the base cover and right side panel in their correct positions.
- 8) Move the control switch to the "ON" position. Replace the front panel in its correct position, then turn on the power supply to start the automatic icemaking process.

Legend: **CB**—control board; **UBC**—ultrasonic bin control

1b. Ultrasonic Bin Control Adjustment

⚠ WARNING

- All parts are factory-adjusted. Improper adjustments may adversely affect safety, performance, component life, and warranty coverage.
- In Hoshizaki DB and DM dispenser applications, the bin control controller setting must be adjusted to 2. For Coca-Cola Freestyle® Dispenser and non-Hoshizaki dispenser applications, the bin control controller setting must be adjusted to 3. Increasing the ice level on any dispenser application could lead to icemaker movement, water leakage, or ice overflow.

NOTICE

- Do not block the bin control lens with top kits or the icemaker will not operate properly.
- Failure to properly adjust the bin control setting could result in water leakage, ice backup, and icemaker damage.

The bin control is factory set to 1 for use on Hoshizaki America standard ice storage bins. See the table below for adjustments to ice level.

WARNING! Do not adjust outside of these settings.

- 1) If not already removed, remove the front, top, and right side panels.
- 2) Confirm bin control controller setting for proper application. See the table below for settings. See Fig. 8. for ice level reference.

Application	Bin Control Ice Level Settings	
	Bin Control Controller Setting	Ice Detection Distance From Bin Control Lens
Default: Standard Ice Storage Bins	1	254 mm (10")
Hoshizaki DB and DM Dispensers	2	305 mm (12")
Coca-Cola Freestyle® Dispenser and Non-Hoshizaki Dispensers	3	406 mm (16")
Optional Settings	4	508 mm (20")
	5	610 mm (24")

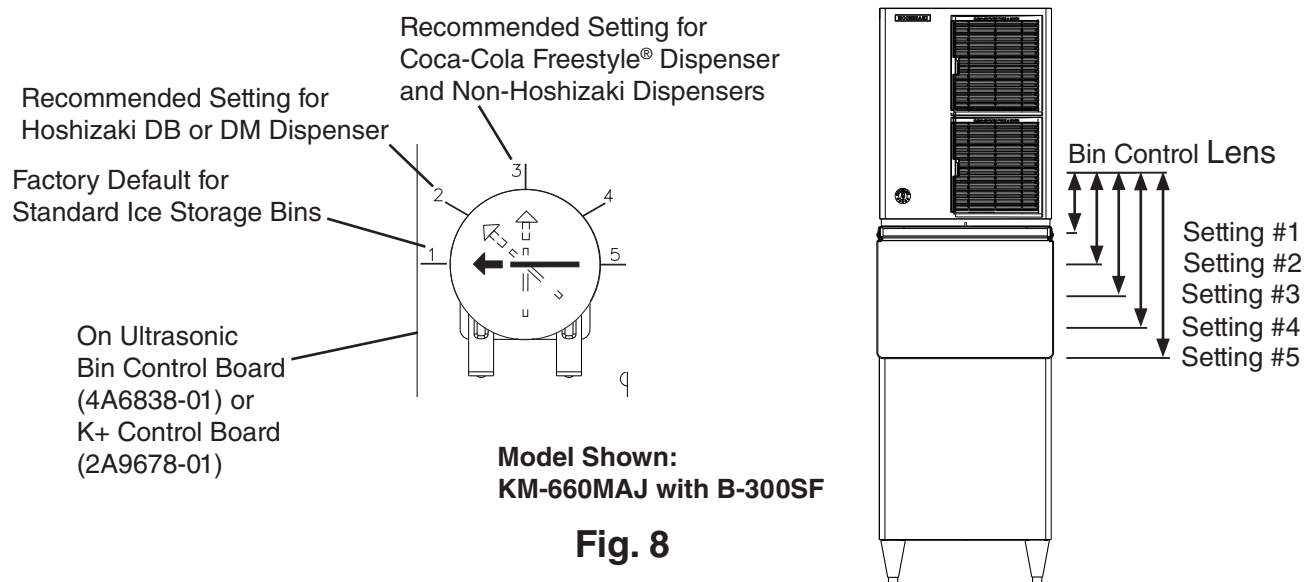

2a. Mechanical Bin Control Check - (2A8598G01)

Model	Auxiliary Code Break
KM-350MAJ	L19077K to L19236K
KM-520MAJ	L02153K to L02411K
KM-660MAJ	L05262K to L05441K
KM-660MWJ	L00674K to L00693K

This appliance uses a lever-actuated proximity switch to control the ice level in the storage bin. No adjustment is required.

To check BC, follow the steps below.

- 1) Turn off the power supply.
- 2) Remove the front panel, then move the control switch to the "OFF" position.
- 3) Remove the control box cover, then clear any ice away from BC.
- 4) Check BC wire harness connections. See Fig. 9.
- 5) Disconnect BC connector from CB K4 connector.
- 6) Check for continuity across the wires of BC connector. When the actuator paddle is not engaged, BC switch is closed. If open, check that the wire harness connector is properly connected and that the actuator paddle is not sticking. Clean if necessary. See "II.D.2a. Bin Control Cleaning." If BC switch still reads open, replace BC.
- 7) Press and hold the actuator paddle; check for continuity across the wires of BC connector. When the actuator paddle is engaged, BC switch is open. If closed, check that the actuator paddle is not restricted. Clean if necessary. See "II.D.2a. Mechanical Bin Control Cleaning." If BC switch still reads closed, replace BC.
- 8) Reconnect BC connector to CB K4 connector, then move the control switch to the "ICE" position. Turn on the power supply.
- 9) Check that CB yellow "BC OPEN/CLOSED" LED is on.
- 10) Allow the icemaker to cycle on. Press and hold the actuator paddle. CB yellow "BC OPEN/CLOSED" LED should turn on and the icemaker should shut down according to the chart below. If it does not, replace CB.

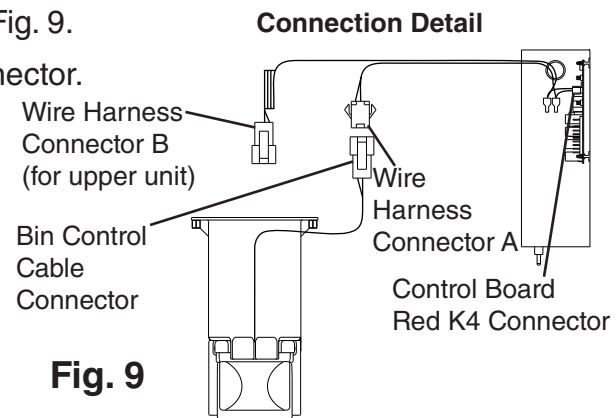

Fig. 9

Cycle at Mechanical Bin Control Activation	Shutdown
Fill Cycle	15 sec. after activation.
Harvest Cycle	At the end of the harvest cycle, or up to 15 sec. into the freeze cycle if activated at the end of the harvest cycle.
Freeze Cycle	15 sec. after activation if activated at least 15 sec. before the 5-min. short cycle protection timer terminates. Otherwise, at the end of the next harvest cycle.

Legend: **BC**—bin control; **CB**—control board

2b. Mechanical Bin Control Cleaning

Scale may build up on BC. Scale can cause the actuator paddle and magnet to stick. In this case, BC should be cleaned.

⚠ WARNING

CHOKING HAZARD: Ensure all components, fasteners, and thumbscrews are securely in place after the icemaker is serviced. Make sure that none have fallen into the dispense unit/ice storage bin.

- 1) Turn off the power supply.
- 2) Remove the front panel, then move the control switch to the "OFF" position.
- 3) Clear any ice away from BC.
- 4) Disconnect BC connector from CB K4 connector, then remove BC from the icemaker.
- 5) Remove the actuator paddle from the switch mount. See Fig. 10.
- 6) Wipe down BC with a mixture of 1 part of Hoshizaki "Scale Away" and 25 parts of warm water. Rinse the parts thoroughly with clean water.
- 7) Reassemble BC and replace it in its correct position.
Note: If the magnet was removed for cleaning, be sure to replace it in its correct position.
- 8) Reconnect BC connector to CB K4 connector, then move the control switch to the "ICE" position.
- 9) Replace the control box cover in its correct position.
- 10) Turn on the power supply to start the automatic icemaking process.
- 11) Replace the front panel in its correct position.

Legend: **BC**—bin control

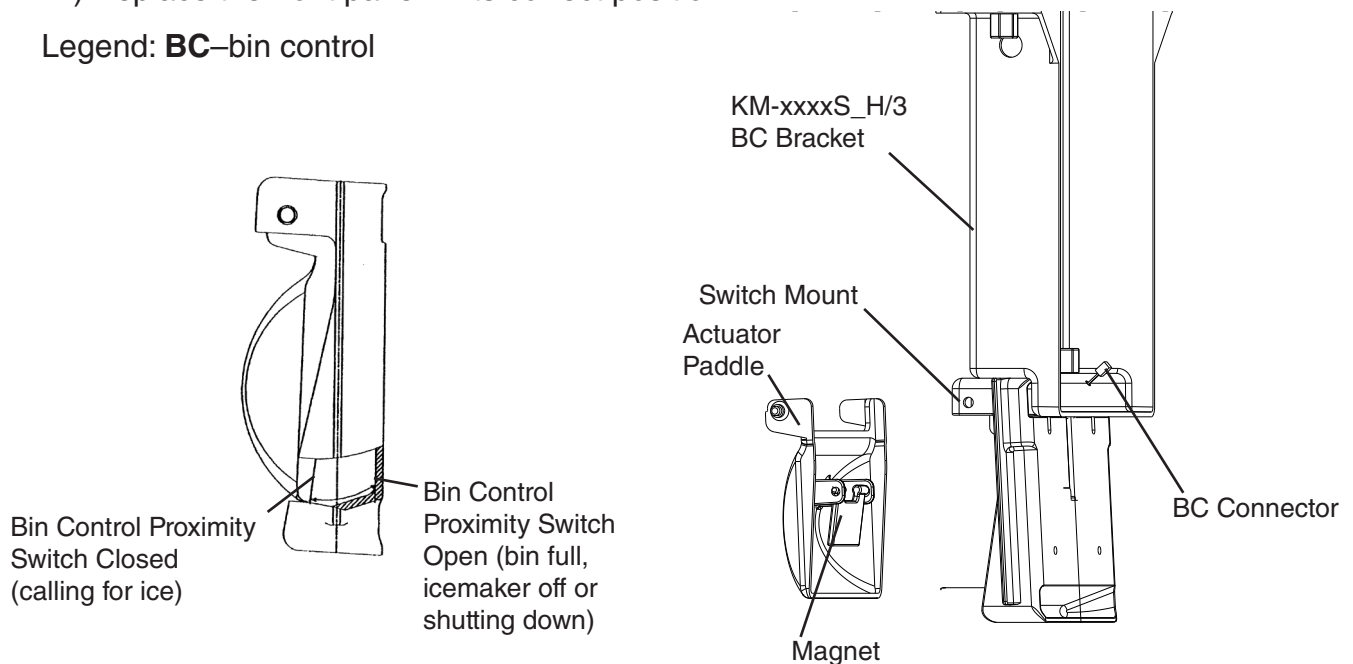

Fig. 10

E. Float Switch Check and Cleaning

FS is used to determine that there is sufficient water in the water tank after the 1-min. fill cycle and after each harvest cycle. FS is also used to determine that the appropriate volume of water has been converted into ice before switching out of the freeze cycle. No adjustment is required.

1. Float Switch Check

To check FS, follow the steps below.

- 1) Turn off the power supply.
- 2) Remove the front panel, then move the control switch to the "OFF" position.
- 3) Drain the water tank. Remove the base cover, then disconnect the water tank end of the pump tubing to drain the water tank. See Fig. 11. After the water tank has drained, reconnect the pump tubing.
- 4) Remove the top and right side panels.
- 5) Disconnect the FS connector from CB K5 connector.
- 6) Check for continuity across FS leads. With the water tank empty, FS should be open. If open, continue to step 7. If closed, follow the steps in "II.E.2. Float Switch Cleaning." After cleaning FS, check it again. Replace if necessary.
- 7) Reconnect FS connector to CB K5 connector, then replace the right side and top panels and the base cover in their correct positions.
- 8) Move the control switch to the "ICE" position. Replace the front panel in its correct position, then turn on the power supply. After 1 min., the 1-min. fill cycle should end and the initial harvest cycle should begin. If the initial harvest cycle begins, FS is good and the check is complete. If the initial harvest cycle does not begin, continue to step 9.
- 9) Turn off the power supply.
- 10) Remove the front panel. Move the control switch to the "OFF" position.
- 11) Remove the top and right side panels.
- 12) Disconnect FS connector from CB K5 connector.
- 13) Check for continuity across FS leads. With the water tank full, FS should be closed. If FS is closed and the icemaker will not switch from the 1-min. fill cycle to the initial harvest cycle, replace CB. If FS is open, confirm that the water tank is full. If the water tank is not full, check the water supply, water filters, and inlet water valve. If the water tank is full, follow the steps in "II.E.2. Float Switch Cleaning." After cleaning FS, check it again. Replace if necessary.
- 14) Replace cube guide and base cover (if applicable) in their correct positions.
- 15) Replace the right side and top panels in their correct positions.
- 16) Move the control switch to the "ICE" position, then replace the front panel in its correct position. Turn on the power supply to start the automatic icemaking process.

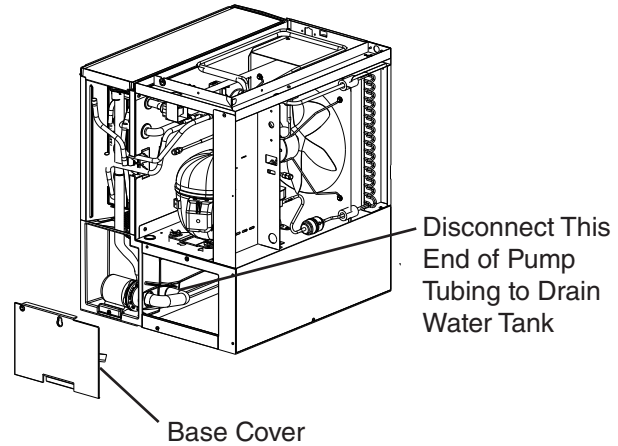

Fig. 11

Legend: **CB**—control board; **FS**—float switch

2. Float Switch Cleaning

Depending on local water conditions, scale may build up on FS. Scale on the switch can cause the float to stick. In this case, FS should be cleaned.

- 1) Turn off the power supply.
- 2) Remove the front panel, then move the control switch to the "OFF" position.
- 3) Remove the base cover, disconnect the water tank end of the pump tubing to drain the water tank. See Fig. 5. After the water tank has drained, reconnect the pump tubing.
- 4) Remove the cube guide, then pull the tab on the float switch bracket to release the float switch assembly from the water tank.
- 5) Remove the spring retainer clip from the float switch rod, then remove the float. Be careful not to bend the spring retainer clip excessively when removing it. See Fig. 12.
- 6) Wipe down the float switch bracket assembly, stem, and float with a mixture of 1 part Hoshizaki "Scale Away" and 25 parts warm water. Rinse the parts thoroughly with clean water. **WARNING! Do not remove the lock nut on the float switch assembly. This is factory sealed and must not be removed.**
- 7) Reassemble the float switch assembly and replace it in its correct position.
- 8) Move the control switch to the "ICE" position.
- 9) Replace the base cover, cube guide, and front panel in their correct positions.
- 10) Turn on the power supply to start the automatic icemaking process.

Legend: **CB**—control board; **FS**—float switch

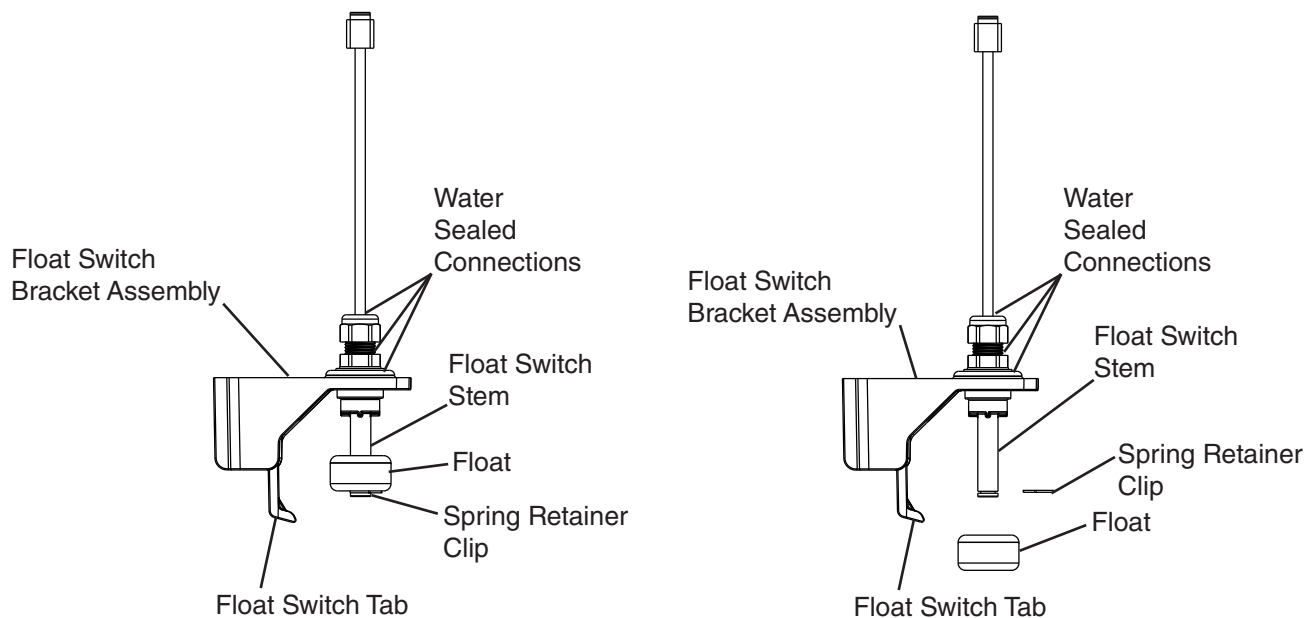

Fig. 12

F. Thermistor Check

To check thermistor resistance, follow the steps below.

- 1) Turn off the power supply.
- 2) Remove the front panel. Move the control switch to the "OFF" position, then remove the top and right side panels.
- 3) Remove the thermistor from the refrigerant tubing.
- 4) Immerse the thermistor sensor portion in a glass containing ice and water for 2 or 3 min.
- 5) Disconnect the thermistor connector from CB K3 connector and check the resistance between thermistor leads. Normal range is 4.7 to 6.2 k Ω . If outside the normal range, replace the thermistor. See "IV.B. Component Service Information." If within the normal range, continue to the next step.
- 6) Replace the thermistor in its correct position. See "IV.B. Component Service Information."
- 7) Reconnect the thermistor connector to CB K3 connector.
- 8) Replace the right side and top panels in their correct positions.
- 9) Move the control switch to the "ICE" position.
- 10) Replace the front panel in its correct position.
- 11) Turn on the power supply.
- 12) Once the harvest cycle starts (Comp energizes), begin timing the harvest cycle.
- 13) The harvest timer and harvest cycle should terminate within 2 to 5 min. If the harvest cycle does not terminate within 2 to 5 min., replace CB.

Legend: **CB**—control board; **Comp**—compressor

G. Control Switch

The control switch has two positions: "ON for power on, "PUMP" to energize the pump motor and circulate the water in the water tank.

H. Mode Switch

The mode switch has two positions: "ICE" for icemaking cycle, "CLEAN" for initiating the cleaning and sanitizing program.

I. Diagnostic Tables

1. No Ice Production

No Ice Production - Possible Cause	
1. Power Supply	a) Off, blown fuse, or tripped breaker.
	b) Not within specifications.
2. Fuse (Control Box)	a) Blown.
3. Control Switch	a) In "OFF" or "PUMP" position.
	b) Defective.
4. High-Pressure Switch	a) Dirty condenser.
	b) Fan motor not operating.
	c) Refrigerant overcharged.
	d) Bad contacts.
	e) Refrigerant lines or components plugged.
5. Control Transformer (115VAC/10.5VAC)	a) Coil winding open or shorted.
6. Control Board See "II.C. Control Board Check"	a) In alarm.
	b) CB yellow "BC OPEN/CLOSED" LED on (bin full)(open).
	c) Defective.
7a. Ultrasonic Bin Control See "II.D.1. Ultrasonic Bin Control Check"	a) Tripped with bin filled with ice.
	b) Sensor lens dirty.
	c) Defective.
7b. Mechanical Bin Control See "II.D.2. Mechanical Bin Control Check"	a) Tripped with bin filled with ice.
	b) Actuator does not move freely.
	c) Defective.
8. Mode Switch	a) In "CLEAN" position.
	b) Defective.
9. Water Supply	a) Water supply off or improper water pressure.
	b) External water filters clogged.
10. Inlet Water Valve	a) Screen or orifice clogged.
	b) Coil winding open.
	c) Water valve open in freeze cycle.
11. Float Switch See "II.E. Float Switch Check and Cleaning"	a) Float does not move freely.
	b) Defective.
12. Compressor	a) Compressor relay/magnetic contactor contacts bad or coil winding open.
	b) Start capacitor or run capacitor defective (single phase).
	c) Internal protector open.
	d) Start relay contacts bad or coil winding open (single phase).
	e) Compressor defective.
13. Hot Gas Valve	a) Closed in harvest cycle.
	b) Open in freeze cycle.
14. Thermistor See "II.F. Thermistor Check"	a) Loose, disconnected, or defective.

No Ice Production - Possible Cause	
15. Pump Motor	a) Motor winding open.
	b) Bearing worn out or locked rotor.
	c) Defective capacitor.
	d) Mechanical seal worn out.
16. Thermostatic Expansion Valve	a) Bulb loose.
	b) Operating erratically.
17. Liquid Line Valve	a) Closed in freeze cycle.
	b) Open in harvest cycle.
18. Fan Motor	a) Motor winding open.
	b) Bearing worn out or locked rotor.
	c) Defective capacitor.
19. Water System	a) Water leaks causing short freeze time.

2. Freeze-Up

Defrost and clean the icemaker prior to diagnosing freeze-up. Fill out a freeze-up checklist. See "II.J. Freeze Up Check List," the Hoshizaki America Technician's Pocket Guide, or contact your local distributor for a copy of the freeze-up checklist.

Freeze-Up - Possible Cause	
Harvest Cycle	
1. Evaporator	a) Scaled up.
	b) Damaged.
2. Cube Guides	a) Out of position.
	b) Damaged.
3. Spray Tubes and/or Spray Guides	a) Dirty.
	b) Out of position.
4. Water Supply	a) Low water pressure.
	b) External water filters clogged.
	c) Insufficient water line size. Minimum 1/4" Nominal ID (6 mm Nominal OD in the EU) copper water tubing or equivalent.
5. Inlet Water Valve	a) Screen or orifice clogged.
	b) Defective.
6. Float Switch See "II.E. Float Switch Check and Cleaning"	a) Dirty, sticking.
	b) Defective.
7. Refrigerant Charge	a) Low.
8. Control Board See "III.C. Settings and Adjustments" and "II.C. Control Board Check"	a) Harvest timer (S4 dip switch 1 & 2) set too short.
	b) Harvest pump timer (S4 dip switch 7) not in factory default position.
	c) Defective.
9a. Ultrasonic Bin Control See "II.D.1. Ultrasonic Bin Control Check"	a) Defective.
9b. Mechanical Bin Control See "II.D.2. Mechanical Bin Control Check"	a) Defective.

Freeze-Up - Possible Cause	
10. Thermistor See "II.F. Thermistor Check"	a) Loose, disconnected, or defective.
11. Thermostatic Expansion Valve	a) Defective.
12. Hot Gas Valve	a) Defective.
13. Liquid Line Valve	a) Defective.
Freeze Cycle	
1. Evaporator	a) Scaled up.
	b) Damaged.
2. Spray Tubes and/or Spray Guides	a) Dirty.
	b) Out of position.
3. Refrigerant Charge	a) Low.
4. Control Board See "II.C. Control Board Check"	a) Freeze timer (S4 dip switch 9 & 10) set incorrectly.
	b) Defective.
5. Inlet Water Valve	a) Leaking by.
6. Float Switch See "II.E. Float Switch Check and Cleaning"	a) Float does not move freely.
	b) Defective.
7. Pump Motor	a) RPM too slow.
	b) Impeller damaged.
8. Thermostatic Expansion Valve	a) Bulb loose or defective.
9. Liquid Line Valve	a) Restricted.
10. Headmaster (C.P.R.) (remote models)	a) Not bypassing.

3. Low Ice Production

Low Ice Production - Possible Cause	
Long Harvest Cycle	
1. Evaporator	a) Scaled up.
2. Spray Tubes and/or Spray Guides	a) Dirty.
	b) Out of position.
3. Refrigerant Charge	a) Low.
4. Water Supply	a) Low water pressure.
	b) External water filters clogged.
	c) Insufficient water line size. Minimum 1/4" Nominal ID (6 mm Nominal OD in the EU) water tubing or equivalent.
	d) Too cold.
5. Control Board See "II.C. Control Board Check"	a) Thermistor connection loose (K3).
	b) Defective.
6. Thermistor See "II.F. Thermistor Check"	a) Loose, disconnected, or defective.
7. Hot Gas Valve	a) Erratic or closed.
8. Inlet Water Valve	a) Screen or orifice clogged.
9. Compressor	a) Inefficient or off.
10. Liquid Line Valve	a) Erratic or open.
11. Thermostatic Expansion Valve	a) Defective.

Low Ice Production - Possible Cause	
Long Freeze Cycle	
1. Evaporator	a) Scaled up, dirty.
2. Float Switch See "II.E. Float Switch Check and Cleaning"	a) Scaled up, dirty.
	b) Float sticking.
	c) Defective switch.
3. Inlet Water Valve	a) Leaking by.
4. Hot Gas Valve	a) Erratic or open.
5. Condenser	a) Clogged.
6. Control Board See "II.C. Control Board Check"	a) Float switch connection loose (K5).
	b) Defective.
7. Refrigerant Charge	a) Low.
8. Thermostatic Expansion Valve	a) Bulb loose.
	b) Defective.
9. Compressor	a) Inefficient or off.
10. Pump Motor	a) RPM too slow.
11. Liquid Line Valve	a) Erratic or restricted.
12. Headmaster (C.P.R.) (remote models)	a) Not bypassing.
13. Splash Guard	a) Out of place.
	b) Missing or damaged.

J. Freeze-Up Check List

Freeze-Up Check List

Please Complete When Diagnosing a Freeze-Up, Refrigerant Leak, or Low Charge

Technical Support Fax #: 770-487-3360

Make Copies And Use As Needed

Model # _____ **Serial #** _____ **Install Date** _____ **Freeze-Up Date** _____

List model and manufacture of bin or dispenser _____.

Date appliance was last cleaned: _____.

Freeze-Up Defrost

YES NO

- [] [] 1) After defrosting, was the appliance leak checked?
 [] [] 2) Were any leaks found?
 If so where? _____.
 [] [] 3) Was any refrigerant added to the unit?
 If so, how much? _____.

Set Up

- [] [] 4) Is the appliance stand alone?
 [] [] 5) Is water line independent?
 [] [] 6) Is water line correct size? If not _____,"
 3/8" Nominal ID Copper Water Tubing or
 Equivalent.
 7) What is water pressure? _____.
 Water Temperature _____.
 [] [] 8) Does appliance have any water filtration?
 If yes please list the following:
 Filter brand _____.
 Model _____.
 Filter pressure gauge reading during the fill
 cycle _____.
 Date filter was last
 replaced? _____.
 GPM or LPM flow rate of filter
 system? _____.
 9) Ambient temperature at appliance?
 _____.
 At remote condenser (if applicable)? _____.

Appliance Status

- [] [] 10) Is the appliance and/or float switch dirty?
 11) List the S4 (1-10) and S5 (1-5) DIP switch
 settings.
 S4: 1 ___ 2 ___ 3 ___ 4 ___ 5 ___ 6 ___ 7 ___ 8 ___ 9 ___ 10 ___
 S5: 1 ___ 2 ___ 3 ___ 4 ___ 5 ___
 [] [] 12) Is DIP switch number 7 ON (harvest pump
 time (harvest assist) all models
 [] [] 13) Is the cube guide positioned correctly?
 [] [] 14) Are the evaporator separators positioned
 properly?
 [] [] 15) Is the thermistor properly mounted, tight, and
 insulated?
 [] [] 16) Is the TXV bulb properly mounted, tight, and
 insulated?
 [] [] 17) Are splash guards in place?

Appliance Sequence of Operation

Fill

YES NO

- [] [] 18) Does the water tank fill and overflow?
 60-90 sec. Note: Larger models may take up to
 120 seconds to overflow when empty.
 [] [] 19) If NO in step 18, is water flow 5GPM for larger?

Harvest

- [] [] 20) Is the hot gas valve opening?
 [] [] 21) Is harvest pump time (harvest assist) utilized (S4
 dip switch 7)?
 [] [] 22) Is hot gas valve opening in harvest?
 [] [] 23) Does water valve close completely when
 de-energized?
 24) What was length of harvest? _____.

Freeze

- [] [] 25) Is pump motor energized in freeze cycle except
 during 10-sec. anti-slush. If activated (S5 dip
 switch 5 on)?
 26) Water-cooled condenser outlet temperature
 5-min. into freeze? _____ °F.
 27) What was length of freeze? _____.
 [] [] 28) Is the cube size consistent from inlet to outlet of
 evaporator?
 [] [] 29) Is ice still dropping when next freeze cycle starts?
 30) What is the ice drop weight? _____.
 31) What is head pressure?
 Freeze _____ Harvest _____.
 (Freeze pressure should be taken 5 minutes into
 the freeze cycle).
 32) What is suction pressure?
 Freeze _____ Harvest _____.
 (Freeze pressure should be taken 5 minutes into
 the freeze cycle).
 [] [] 33) When activating bin control, did appliance
 shutdown within 15 seconds in the first 5 minutes
 of freeze cycle?

III. Controls and Adjustments

- A Hoshizaki exclusive control board is employed in KM series appliances.
- All models are pretested and factory adjusted.
- For a control board check procedure, see "II.D. Control Board Check."

<i>NOTICE</i>
<ul style="list-style-type: none">• Fragile, handle very carefully.• The control board contains integrated circuits, which are susceptible to failure due to static discharge. It is especially important to touch the metal part of the icemaker when handling or replacing the control board.• Do not touch the electronic devices on the control board or the back of the control board.• Do not change wiring and connections. Do not misconnect K3 WHITE, K4 RED, and K5 BLACK, because the same connector is used for the thermistor, bin control (mechanical bin control), and float switch.• Do not short out power supply to test for voltage.• Always replace the whole control board assembly if it goes bad.

A. Control Board Layout

1. K Control Board (2A8242-02)

K Control Board

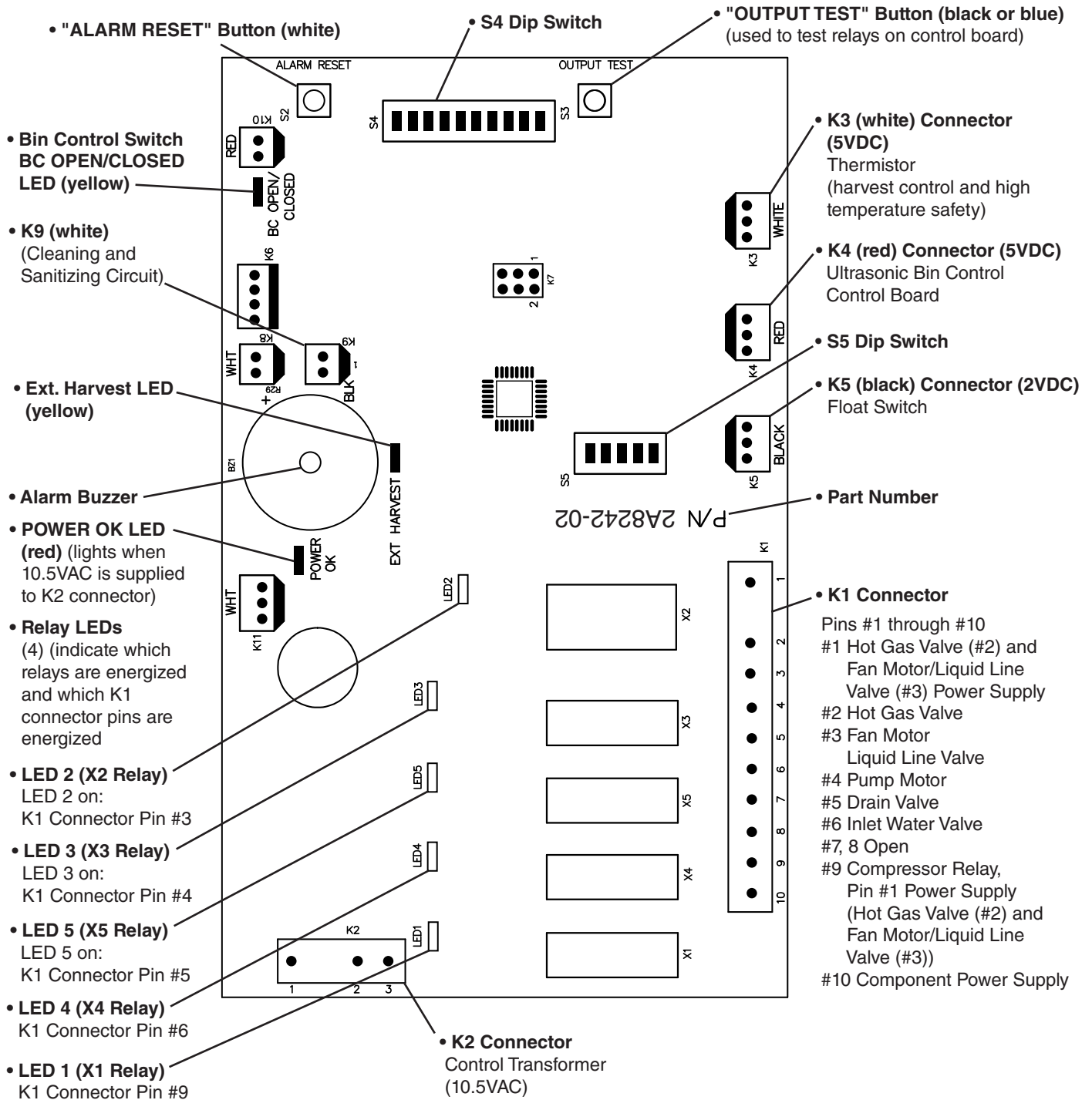

Control Board	
Part Number	2A8242-02

2. K+ Control Board (2A9678-01)

K+ Control Board

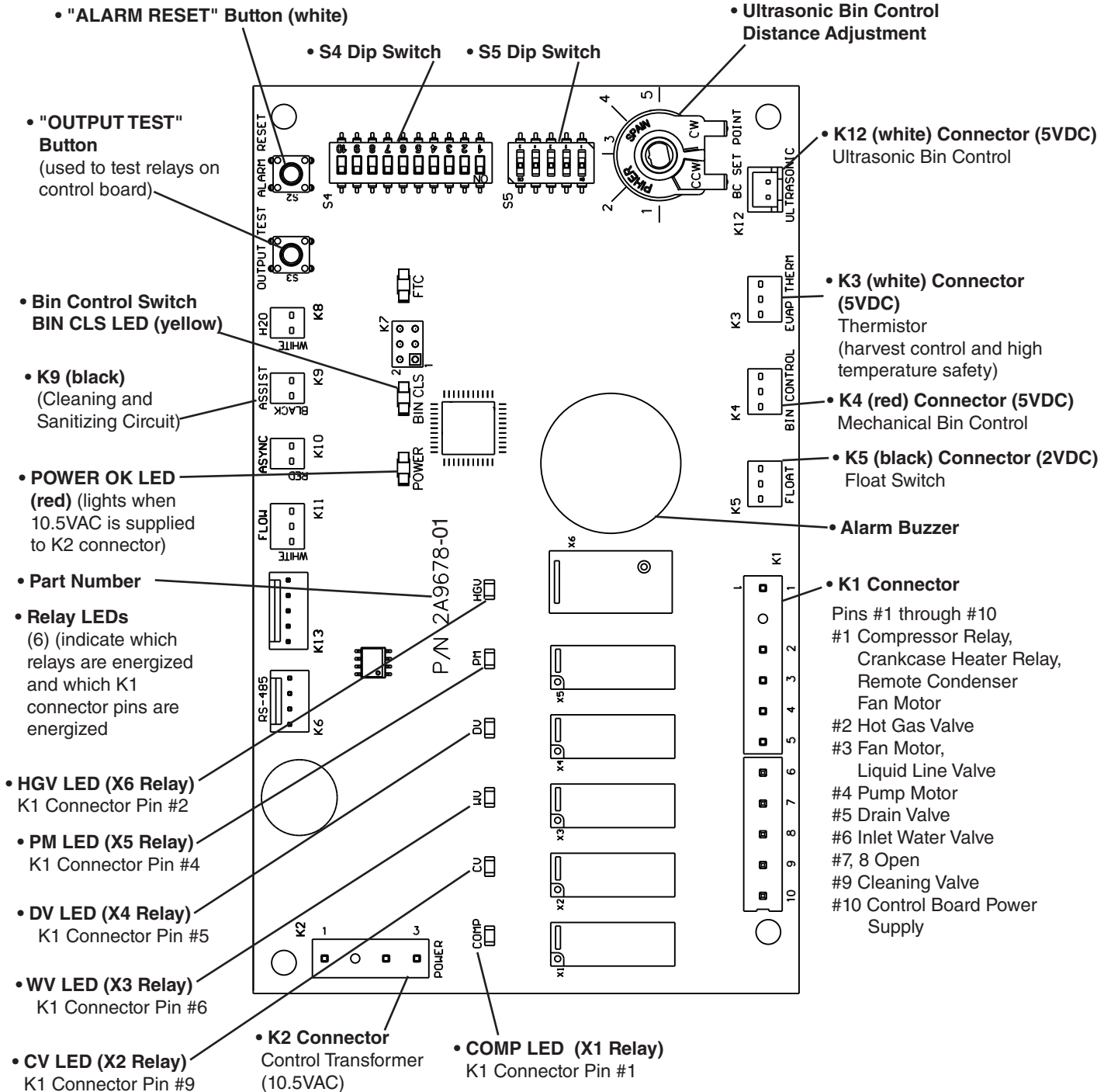

Control Board	
Part Number	2A9678-01

B. LED Lights and Audible Alarm Safeties

1. K Control Board (2A8242-02)

Beep occurs and red CB "POWER OK" LED turns on when control switch is moved to "ICE" position.

Sequence

Green LEDs 1 through 5 turn on and sequence from initial startup as listed in the table below. Order of green LEDs from the outer edge of control board is 1, 4, 5, 3, 2.

Sequence Step	LED	Energized Components	Time LEDs are On	
			Min.	Max.
1-Minute Fill Cycle	4	WV		
Harvest Cycle	1, 4	Comp, FMR, HGV, WV	1 minute	20 minutes
Harvest Pump Time (harvest assist)	1, 3	Comp, FMR, HGV, PM	0 seconds	50 seconds
Freeze Cycle	1, 2, 3	Comp, FM/FMR, PM, LLV	5 minutes	freeze timer setting
Anti-Slush Control	1, 2	Comp, FM/FMR, LLV	PM off 10 sec. when thermistor at 36°F (2°C)	
Pump-Out Cycle	1, 4, 5, 3	Comp, FMR, HGV, PM, WV*, DV	10 seconds	20 seconds

*pump-out timer setting

Alarms

Type	Alarm	Notes
1 Beep	High Evaporator Temp. (temperature > 127°F) (53°C)	Check for harvest problem (stuck HGV or relay), hot water entering unit, stuck HM, or shorted thermistor.
2 Beep	Harvest Backup Timer (harvest > 20 min. for two cycles in a row)	Check thermistor (open), HGV not opening, TXV or LLV leaking by, low charge, inefficient Comp, or WRV leaking by.
3 Beep	Freeze Timer (freeze > freeze timer setting for two cycles in a row)	Check FS stuck closed (up), WV leaking by, HGV leaking by, PM not pumping, TXV defective, LLV not opening, low charge, HM not bypassing, or inefficient Comp.
To reset above safeties, press "ALARM RESET" button with power supply on.		
6	Low Voltage (92Vac±5% or less)	Red LED turns off if voltage protection operates. Control voltage safeties automatically reset when voltage is corrected.
7	High Voltage (147Vac±5% or more)	

Legend: **Comp**—compressor; **DV**—drain valve; **FM**—fan motor; **FMR**—fan motor remote; **FS**—float switch; **HGV**—hot gas valve; **HM**—headmaster (C.P.R.); **LLV**—liquid line valve; **PM**—pump motor; **TXV**—thermostatic expansion valve; **WRV**—water regulating valve; **WV**—inlet water valve

2. K+ Control Board (2A9678-01)

Beep occurs and red CB "POWER OK" LED turns on when control switch is moved to "ICE" position.

Sequence

Green LEDs turn on and sequence from initial startup as listed in the table below. Order of green LEDs from the outer edge of control board is Comp, CV, WV, DV, PM, FM/HGV.

Sequence Step	LED	Energized Components	Time LEDs are On	
			Min.	Max.
1-Minute Fill Cycle	WV	WV		
Harvest Cycle	Comp, WV, **FM/HGV	Comp, FMR, HGV, WV	1 minute	20 minutes
Harvest Pump Time (harvest assist)	Comp, PM, **FM/HGV	Comp, FMR, HGV, PM	0 seconds	50 seconds
Freeze Cycle	Comp, PM	Comp, FM/FMR, PM, LLV	5 minutes	freeze timer setting
Anti-Slush Control	Comp	Comp, FM/FMR, LLV	PM off 10 sec. when thermistor at 36°F (2°C)	
Pump-Out Cycle	Comp, PM, **FM/HGV, DV, *WV	Comp, FMR, HGV, PM, *WV, DV	10 seconds	20 seconds
*pump-out timer setting **FM is OFF when FM/HGV is ON				

Alarms

Type	Alarm	Notes
1 Beep	High Evaporator Temp. (temperature > 127°F) (53°C)	Check for harvest problem (stuck HGV or relay), hot water entering unit, stuck HM, or shorted thermistor.
2 Beep	Harvest Backup Timer (harvest > 20 min. for two cycles in a row)	Check thermistor (open), HGV not opening, TXV or LLV leaking by, low charge, inefficient Comp, or WRV leaking by.
3 Beep	Freeze Timer (freeze > freeze timer setting for two cycles in a row)	Check FS stuck closed (up), WV leaking by, HGV leaking by, PM not pumping, TXV defective, LLV not opening, low charge, HM not bypassing, or inefficient Comp.
To reset above safeties, press "ALARM RESET" button with power supply on.		
6	Low Voltage (92Vac±5% or less)	Red LED turns off if voltage protection operates. Control voltage safeties automatically reset when voltage is corrected.
7	High Voltage (147Vac±5% or more)	

Legend: **Comp**—compressor; **CV**—cleaning valve; **DV**—drain valve; **FM**—fan motor; **FMR**—fan motor remote; **FS**—float switch; **HGV**—hot gas valve; **HM**—headmaster (C.P.R.); **LLV**—liquid line valve; **PM**—pump motor; **TXV**—thermostatic expansion valve; **WRV**—water regulating valve; **WV**—inlet water valve

C. Settings and Adjustments

NOTICE

Dip switches are factory set. Failure to maintain factory settings may adversely affect performance and warranty coverage. For more information, contact your Hoshizaki Service Center.

1. Default Dip Switch Settings

The dip switches are factory-adjusted to the following positions:

S4 Dip Switch No.	1	2	3	4	5	6	7	8	9	10
KM-350MAJ, KM-350MWJ	OFF	OFF	OFF	ON	ON	OFF	ON	OFF	ON	ON
KM-420MAJ, KM-420MWJ, KM-420MRJZ	OFF	OFF	OFF	OFF	OFF	OFF	ON	OFF	ON	ON
KM-520MAJ, KM-520MWJ, KM-520MRJ(Z)	OFF	OFF	OFF	OFF	OFF	OFF	ON	OFF	ON	ON
KM-660MAJ, KM-660MWJ, KM-660MRJ(Z)	OFF	OFF	OFF	OFF	OFF	OFF	ON	OFF	ON	ON

S5 Dip Switch (Do Not Adjust)					
Dip Switch No.	1	2	3	4	5
All Models	OFF	OFF	OFF	OFF	ON

S4 Dip Switch

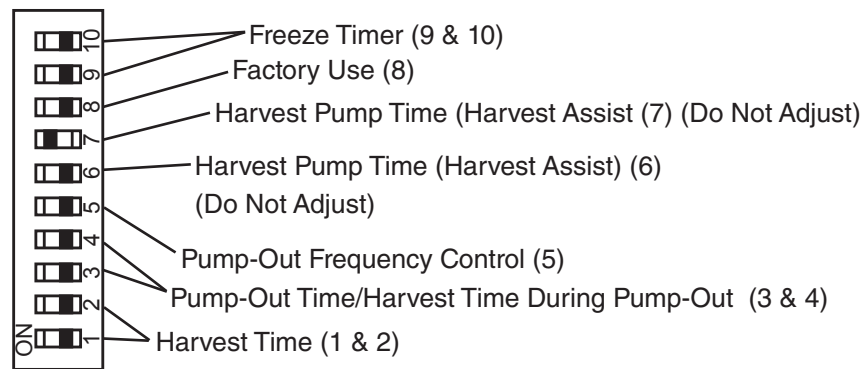

S5 Dip Switch

(Do Not Adjust)

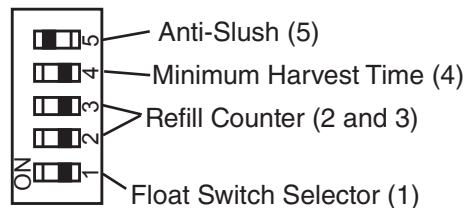

2. Harvest Time (S4 dip switch 1 & 2)

The harvest timer starts counting when the thermistor reaches 48°F (9°C) at the evaporator outlet and the control board reads 3.9 kΩ from the thermistor. The harvest timer is factory set, and generally no adjustment is required. However, a setting longer than the factory setting may be advised in cases where the drain provided at harvest needs to be prolonged for extra cleaning. Note that the pump-out timer (S4 dip switch 3 & 4) acts in place of the harvest timer during cycles with a pump out.

For details, see "III.C.3. Pump-Out Timer (S4 dip switch 3 & 4)."

Note: On models with a pump-out every cycle, the harvest timer is only relevant during the initial harvest cycle since a pump out occurs every cycle thereafter.

S4 Dip Switch Setting		Time (sec.)	
No. 1	No. 2	S5-4 OFF	S5-4 ON
OFF	OFF	60	30
ON	OFF	90	45
OFF	ON	120	60
ON	ON	180	75

3. Pump-Out Time/Harvest Time During Pump-Out (S4 dip switch 3 & 4)

When a pump-out is called for, the pump motor stops for 2 sec. After 2 sec. the drain valve and pump motor energize. On KM-350M_J models the inlet water valve also energizes. Water is removed from the bottom of the water tank and sent down the drain. The pump-out drains the water tank for the time determined by the pump-out timer. The pump-out timer also acts in place of the harvest timer during cycles with a pump-out. The pump-out timer is factory set, and generally no adjustment is required. However, where water quality is bad and the icemaker needs a longer pump-out time, the pump-out timer can be adjusted. The pump-out timer control can be set to pump-out for 10 or 20 sec. During pump-out cycles minimum harvest time is based on times given in the table below.

S4 Dip Switch Setting		Time (sec.)			Inlet Water Valve	
No. 3	No. 4	T1	T2		S5-4 OFF	S5-4 ON
			S5-4 OFF	S5-4 ON		
OFF	OFF	10	150	100	Closed	Closed
ON	OFF	10	180	130	Closed	Closed
OFF	ON	10	120	70	Open	Closed
ON	ON	20	180	180	Closed	Closed

T1: Time to drain the water tank

T2: Harvest timer at pump out

4. Pump-Out Frequency Control (S4 dip switch 5)

The pump-out frequency control is factory set to drain the water tank every 10 cycles. Generally no adjustment is required. However, where water quality is bad and the icemaker needs a pump-out more often, the pump-out frequency can be adjusted. The pump-out frequency control can be set to have a pump-out occur every cycle, or every 10 cycles.

The first pump-out is dependent on S4 dip switch 5. See the table below.

S4 Dip Switch Setting	Pump-Out Frequency	1st Pump-Out
No. 5		
OFF	Every 10 cycles	After 11th freeze cycle
ON	Every cycle	After 2nd freeze cycle

5. Harvest Pump Time (Harvest Assist) (S4 dip switch 6)

NOTICE

Factory set for proper operation. Do not adjust. Adjustment outside of the factory default setting may result in damage to the appliance.

Harvest pump time (harvest assist) is only active when S4 dip switch 7 is in the "ON" position. In the factory default position, the harvest pump time (harvest assist) starts with 50 sec. left to go in harvest cycle (S4 dip switch 6) and after the thermistor reaches 48°F (9°C) at the evaporator outlet and the control board reads 3.9 kΩ from the thermistor. The harvest pump time (harvest assist) is factory set, and no adjustment is required.

S4 Dip Switch Setting	Harvest Pump Time (Harvest Assist)	
	S5-4 OFF	S5-4 ON
No. 6		
OFF	50 sec.	25 sec.
ON	25 sec.	15 sec.

6. Harvest Pump Time (Harvest Assist (S4 dip switch 7))

NOTICE

Factory set for proper operation. Do not adjust. Adjustment outside of the factory default setting may result in damage to the appliance.

Depending on S4 dip switch 7 setting, the pump motor either stays off or is energized during the last seconds of the harvest cycle. When the pump motor is energized (S4 dip switch 7 on), water circulates over the evaporator. The harvest water valve is open during harvest for a maximum of 6 minutes or the length of harvest minus the harvest pump time value(S4 dip switch 6), whichever is shorter.

When S4 dip switch 7 is in the on position and harvest begins, 50 sec. before harvest termination, LED 4 turns off, inlet water valve Next, LED 3 turns on and control board K1 connector pin #4 (R) energizes, energizing the pump motor for the last seconds of harvest. Harvest pump time adjusted by S4 dip switch 1 & 2 and S5 dip switch 4 settings. Contact Technical Support before adjusted these settings.

S4 Dip Switch Setting		Harvest Pump Time (sec.) (Harvest Assist)
No. 7		
OFF		0
ON		50

7. Factory Use (S4 dip switch 8)

Factory set for proper operation. Do not adjust. This must be left in the factory default position.

8. Freeze Timer (S4 dip switch 9 & 10)

NOTICE

Adjust to proper specification, or the icemaker may not operate correctly.

The freeze timer setting determines the maximum allowed freeze time to prevent possible freeze-up issues. Upon termination of the freeze timer, the control board initiates the harvest cycle or pump-out cycle. After 2 consecutive freeze timer terminations, the control board shuts down the icemaker. In this case, see "II.I.3. Low Ice Production" for possible solutions. The freeze timer is factory set and no adjustment is required. Before changing this setting, contact Hoshizaki Technical Support at 1-800-233-1940 for recommendations.

S4 Dip Switch Setting		Time (min.)
No. 9	No. 10	
OFF	OFF	60
OFF	ON	50
ON	OFF	70
ON	ON	75

9. Float Switch Selector (S5 dip switch 1)

NOTICE

Do not adjust. This must be left in the factory default position or the icemaker will not operate correctly.

This dip switch setting allows use of this control board in single and dual float switch models. This model uses a single float switch style.

S5 Dip Switch Setting		Top or Bottom Float Switch Control
No. 1		
OFF		Bottom Float Switch Enabled
ON		Top Float Switch Enabled

10. Refill Counter (S5 dip switch 2 and 3)

NOTICE

Do not adjust. These must be left in the factory default position or the icemaker will not operate correctly.

S5 Dip Switch Setting		Refill Counter
No. 2	No. 3	
OFF	OFF	0
OFF	ON	1 refill
ON	OFF	9 refills
ON	ON	10 refills

11. Minimum Harvest Time (S5 dip switch 4)

NOTICE

Factory set for proper operation. Do not adjust. Adjustment outside the factory default setting may result in damage to the appliance.

S5 Dip Switch Setting	Minimum Harvest Timer
No. 4	
OFF	120 sec.
ON	70 sec.

12. Anti-Slush (S5 dip switch 5)

This dip switch setting provides anti-slush control during the freeze cycle. When the evaporator temperature reaches 36°F (2.2°C) the control board reads a 5.8 kΩ signal from the thermistor and de-energizes the water pump for 10 sec. to melt the ice slush and prevent the ice slush from blocking the water supply tubing, causing irregular freeze patterns.

NOTICE

Factory set for proper operation. Do not adjust. Adjustment outside the factory default setting may result in damage to the appliance.

S5 Dip Switch Setting	
No. 5	Anti-Slush
OFF	Disabled
ON	Enabled

IV. Refrigeration Circuit and Component Service Information

⚠ WARNING

- This appliance should be diagnosed and repaired only by qualified service personnel to reduce the risk of death, electric shock, serious injury, or fire.
- Move the control switch to the "OFF" position and turn off the power supply. Place the disconnect in the "OFF" position. Lockout/Tagout to prevent the power supply from being turned back on inadvertently.
- **CHOKING HAZARD:** Ensure all components, fasteners, and thumbscrews are securely in place after the icemaker is serviced. Make sure that none have fallen into the dispenser unit/ice storage bin.
- Make sure all food zones in the icemaker and dispenser unit/ice storage bin are clean after service.

A. Refrigeration Circuit Service Information

MAJ, MWJ, and MRJ models

⚠ WARNING

- Repairs requiring the refrigeration circuit to be opened must be performed by properly trained and EPA-certified service personnel.
- Use an electronic leak detector or soap bubbles to check for leaks. Add a trace of refrigerant to the system (if using an electronic leak detector), and then raise the pressure using nitrogen gas (140 PSIG). Do not use R-404A as a mixture with pressurized air for leak testing.

NOTICE

- Always recover the refrigerant and store it in an approved container. Do not discharge the refrigerant into the atmosphere.
- Do not leave the system open for longer than 15 min. when replacing or servicing parts. The Polyol Ester (POE) oils used in R-404A applications can absorb moisture quickly. Therefore it is important to prevent moisture from entering the system when replacing or servicing parts.
- Always install a new drier every time the sealed refrigeration system is opened. Do not replace the drier until after all other repair or replacement has been made. Install the new drier with the arrow on the drier in the direction of the refrigerant flow.
- When brazing, protect the drier by using a wet cloth to prevent the drier from overheating. Do not allow the drier to exceed 250°F (121°C).

1. Refrigerant Recovery

The icemaker is provided with refrigerant access valves. Using proper refrigerant practices, recover the refrigerant. Store the refrigerant in an approved container. Do not discharge the refrigerant into the atmosphere.

2. Brazing

⚠ WARNING

- R-404A itself is not flammable at atmospheric pressure and temperatures up to 176°F (80°C).
- R-404A itself is not explosive or poisonous. However, when exposed to high temperatures (open flames), R-404A can be decomposed to form hydrofluoric acid and carbonyl fluoride both of which are hazardous.
- Do not use silver alloy or copper alloy containing arsenic.

- 1) Braze all fittings while purging with nitrogen gas flowing at a pressure of 3 to 4 PSIG.
Note: Because the pipes in the evaporator case are specially coated to resist corrosion, it is important to make connections outside the evaporator case when possible. If it is necessary to braze inside the evaporator case, use sandpaper to remove the coating from the brazing connections before unbrazing the components.

NOTICE

- Always install a new drier every time the sealed refrigeration system is opened.
- Do not replace the drier until after all other repair or replacement has been made. Install the new drier with the arrow on the drier in the direction of the refrigerant flow.
- When brazing, protect the drier by using a wet cloth to prevent the drier from overheating. Do not allow the drier to exceed 250°F (121°C).

- 2) Use an electronic leak detector or soap bubbles to check for leaks. Add a trace of refrigerant to the system (if using an electronic leak detector), and then raise the pressure using nitrogen gas (140 PSIG). Do not use R-404A as a mixture with pressurized air for leak testing.

3. Evacuation and Recharge (R-404A)

- 1) Attach a vacuum pump to the system. Be sure to connect the charging hoses to both high and low-side refrigerant access valves.

IMPORTANT

The vacuum level and vacuum pump may be the same as those for current refrigerants. However, the rubber hose and gauge manifold to be used for evacuation and refrigerant charge should be exclusively for POE oils.

- 2) Turn on the vacuum pump. Open the gauge manifold valves. Never allow the oil in the vacuum pump to flow backwards.
- 3) Allow the vacuum pump to pull down to a 29.9" Hg vacuum. Evacuating period depends on pump capacity.
- 4) Close the low-side valve and high-side valve on the gauge manifold.

- 5) Disconnect the gauge manifold hose from the vacuum pump and attach it to a refrigerant service cylinder. Remember to loosen the connection and purge the air from the hose. For the required refrigerant charge, see the rating label inside the icemaker. Hoshizaki recommends only virgin refrigerant or reclaimed refrigerant which meets ARI Standard 700 (latest edition) be used.
- 6) A liquid charge is required when charging an R-404A system (to prevent fractionation). Place the service cylinder on the scales; if the service cylinder is not equipped with a dip tube, invert the service cylinder, then place it on the scales. Open the high-side valve on the gauge manifold.
- 7) Allow the system to charge with liquid until the proper charge weight is met.
- 8) If necessary, add any remaining charge to the system through the low-side.
NOTICE! To prevent compressor damage, use a throttling valve or liquid dispensing device to add the remaining liquid charge through the low-side refrigerant access valve with the icemaker running.
- 9) Close the high and low-side gauge manifold valves, then disconnect the gauge manifold hoses.
- 10) Cap the refrigerant access valves to prevent a possible leak.

B. Refrigeration Circuit Service Information

MRJZ models with URC-5FZ

WARNING

- Repairs requiring the refrigeration circuit to be opened must be performed by properly trained and EPA-certified service personnel.
- Use an electronic leak detector or soap bubbles to check for leaks. Add a trace of refrigerant to the system (if using an electronic leak detector), and then raise the pressure using nitrogen gas (140 PSIG). Do not use R-404A as a mixture with pressurized air for leak testing.

NOTICE

- Always recover the refrigerant and store it in an approved container. Do not discharge the refrigerant into the atmosphere.
- Do not leave the system open for longer than 15 min. when replacing or servicing parts. The Polyol Ester (POE) oils used in R-404A applications can absorb moisture quickly. Therefore it is important to prevent moisture from entering the system when replacing or servicing parts.
- Always install a new drier every time the sealed refrigeration system is opened. Do not replace the drier until after all other repair or replacement has been made. Install the new drier with the arrow on the drier in the direction of the refrigerant flow.
- When brazing, protect the drier by using a wet cloth to prevent the drier from overheating. Do not allow the drier to exceed 250°F (121°C).

1. Refrigerant Recovery

The condensing unit and icemaker are provided with refrigerant shutoff valves. Using proper refrigerant practices, recover the refrigerant. Recovery via the condensing unit's refrigerant shutoff valves is recommended. Store the refrigerant in an approved container. Do not discharge the refrigerant into the atmosphere.

2. Brazing

WARNING

- R-404A itself is not flammable at atmospheric pressure and temperatures up to 176°F (80°C).
- R-404A itself is not explosive or poisonous. However, when exposed to high temperatures (open flames), R-404A can be decomposed to form hydrofluoric acid and carbonyl fluoride both of which are hazardous.
- Do not use silver alloy or copper alloy containing arsenic.

1) Braze all fittings while purging with nitrogen gas flowing at a pressure of 3 to 4 PSIG.

Note: Because the pipes in the evaporator case are specially coated to resist corrosion, it is important to make connections outside the evaporator case when possible. If it is necessary to braze inside the evaporator case, use sandpaper to remove the coating from the brazing connections before unbrazing the components.

NOTICE

- Always install a new drier every time the sealed refrigeration system is opened.
- Do not replace the drier until after all other repair or replacement has been made. Install the new drier with the arrow on the drier in the direction of the refrigerant flow.
- When brazing, protect the drier by using a wet cloth to prevent the drier from overheating. Do not allow the drier to exceed 250°F (121°C).

- 2) Use an electronic leak detector or soap bubbles to check for leaks. Add a trace of refrigerant to the system (if using an electronic leak detector), and then raise the pressure using nitrogen gas (140 PSIG). Do not use R-404A as a mixture with pressurized air for leak testing.

3. Evacuation and Recharge (R-404A)

The condensing unit and icemaker are provided with refrigerant shutoff valves. Evacuation and recharge via the condensing unit's refrigerant shutoff valves is recommended.

- 1) Attach a vacuum pump to the system. Be sure to connect the charging hoses to both high and low-side refrigerant shutoff valves.

IMPORTANT

The vacuum level and vacuum pump may be the same as those for current refrigerants. However, the rubber hose and gauge manifold to be used for evacuation and refrigerant charge should be exclusively for POE oils.

- 2) Turn on the vacuum pump. Open the gauge manifold valves, then open the high and low-side refrigerant shutoff valves. Never allow the oil in the vacuum pump to flow backwards.
- 3) Allow the vacuum pump to pull down to a 29.9" Hg vacuum. Evacuating period depends on pump capacity.
- 4) Close the low-side valve and high-side valve on the gauge manifold.
- 5) Disconnect the gauge manifold hose from the vacuum pump and attach it to a refrigerant service cylinder. Remember to loosen the connection and purge the air from the hose. For the required refrigerant charge, see the nameplate on the condensing unit or the rating label inside the icemaker. Hoshizaki recommends only virgin refrigerant or reclaimed refrigerant which meets ARI Standard 700 (latest edition) be used.

- 6) A liquid charge is required when charging an R-404A system (to prevent fractionation). Place the service cylinder on the scales; if the service cylinder is not equipped with a dip tube, invert the service cylinder, then place it on the scales. Open the high-side valve on the gauge manifold.
- 7) Allow the system to charge with liquid until the proper charge weight is met.
- 8) If necessary, add any remaining charge to the system through the low-side.
NOTICE! To prevent compressor damage, use a throttling valve or liquid dispensing device to add the remaining liquid charge through the low-side refrigerant shutoff valve with the icemaker running.
- 9) Close the high and low-side refrigerant shutoff valves. Close the high and low-side gauge manifold valves, then disconnect the gauge manifold hoses.
- 10) Cap the refrigerant shutoff valves to prevent a possible leak.

C. Component Service Information

NOTICE

When replacing a component listed below, see the notes to help ensure proper operation.

Component	Notes
Compressor	1 phase: Install a new start capacitor, run capacitor, and start relay.
Thermostatic Expansion Valves	<ul style="list-style-type: none"> • Attach the thermostatic expansion valve bulb to the suction line in the same location as the previous bulb. • The bulb should be between the 10 and 2 o'clock positions on the tube. • Secure the bulb with the clamp and holder, then insulate it.
Hot Gas Valves Liquid Line Valves	<ul style="list-style-type: none"> • Replace the strainer if applicable. • Use copper tube of the same diameter and length when replacing valve lines.
Fan Motors	Install a new capacitor.
Pump Motor	Install a new capacitor.
Thermistor	<ul style="list-style-type: none"> • Attach the new thermistor to the suction line in the same location as the previous thermistor. • The thermistor should be at the 12 o'clock position on the tube. • Smoothly fill the recessed area of the thermistor holder with high thermal conductive type sealant. Hoshizaki America part number 4A0683-01 (Silicone Heat Sink Compound 10-8108 manufactured by GC Electronics), KE-4560 RTV (manufactured by ShinEtsu Silicones), or equivalent are recommended. • Secure the thermistor with the holder, then insulate it. • Be very careful to prevent damage to the leads.

D. Water Regulating Valve Adjustment (water-cooled model)

The water regulating valve is factory set, and generally no adjustment is required. However, when necessary, adjust the water regulator using the following procedure.

- 1) Prepare a thermometer to check the condenser drain temperature. Attach a pressure gauge to the high-side line of the system.
- 2) 5 min. after a freeze cycle starts, confirm that the thermometer reads 104°F to 115°F (40°C to 46°C). If it does not, rotate the adjustment screw by using a flat blade screwdriver until the temperature is in the proper range. See Fig. 13. Next, check that the reference pressure is in the range indicated in the Head Pressure table in the Performance Data section. If it is not in the proper range, verify the refrigerant charge.
- 3) Check that the condenser drain temperature is stable.

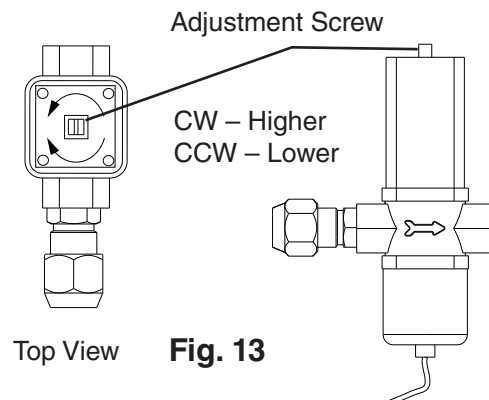

V. Maintenance

The maintenance schedule below is a guideline. More frequent maintenance may be required depending on water quality, the appliance's environment, and local sanitation regulations

WARNING

- Only qualified service technicians should service the appliance.
- To reduce the risk of electric shock, do not touch the control switch or service switch with damp hands
- Before servicing: Move the control switch to the "OFF" position and turn off the power supply. Place the disconnect in the "OFF" position. Lockout/Tagout to prevent the power supply from being turned back on inadvertently.
- **CHOKING HAZARD:** Ensure all components, fasteners, and thumbscrews are securely in place after any maintenance is done to the icemaker. Make sure that none have fallen into the dispenser unit/ice storage bin.

Maintenance Schedule

Frequency	Area	Task
Daily	Scoop	Clean the ice scoop using a neutral cleaner. Rinse thoroughly after cleaning.
Bi-Weekly	Air Filters	Inspect. Wash with warm water and neutral cleaner if dirty.
Monthly	External Water Filters	Check for proper pressure and change if necessary.
	Bin Control Lens	Wipe down the bin control lens, (located on the bottom of the icemaker) with a neutral cleaner. Rinse thoroughly after cleaning.
	Icemaker Exterior	Wipe down with a clean, soft cloth. Use a damp cloth containing a neutral cleaner to wipe off oil or dirt build up. Clean any chlorine staining (rust colored spots) using a non-abrasive cleanser.
	Underside of Icemaker and Top Kits; Bin Door and Snout	Wipe down with a clean cloth and warm water.
Yearly	Icemaker and Dispenser Unit/Ice Storage Bin Liner	Clean and sanitize per the cleaning and sanitizing instructions provided in the instruction manual or maintenance label on the icemaker.
	Water Supply Inlet	Close the icemaker water supply line shut-off valve and drain the water system. Clean the water supply inlet screen.
	Condenser	Inspect. Clean if necessary by using a brush or vacuum cleaner. More frequent cleaning may be required depending on location.
	Water Hoses	Inspect the water hoses and clean/replace if necessary.

VI. Preparing the Appliance for Periods of Non-Use

NOTICE

- When storing the appliance for an extended time or in sub-freezing temperatures, follow the instructions below to prevent damage.
- To prevent damage to the water pump, do not operate the appliance with the control switch in the "PUMP" position when the water tank is empty.

When the appliance is not used for two or three days under normal conditions, it is sufficient to move the control switch to the "OFF" position. When storing the appliance for an extended time or in sub-freezing temperatures, follow the instructions below.

1. Remove the water from the icemaker water line:

- 1) Turn off the power supply, then remove the front panel.
- 2) Close the icemaker water supply line shut-off valve and open the icemaker water supply line drain valve.
- 3) Allow the line to drain by gravity.
- 4) Attach a compressed air or carbon dioxide supply to the icemaker water supply line drain valve.
- 5) Make sure at least 3 min. have elapsed since you turned off the power supply. Make sure the control switch is in the "ICE" position. Replace the front panel in its correct position, then turn on the power supply.
- 6) Blow the icemaker water supply line out using the compressed air or carbon dioxide supply.
- 7) Close the icemaker water supply line drain valve.

2. Remove the water from the water tank:

- 1) Turn off the power supply, then remove the front panel.
- 2) Move the control switch to the "OFF" position.
- 3) Drain the water tank. Remove the base cover, then disconnect one end of the pump tubing to drain the water tank. See Fig. 14. After the water tank has drained, reconnect the pump tubing.
- 4) Replace the base cover (if applicable) and front panel in their correct positions.

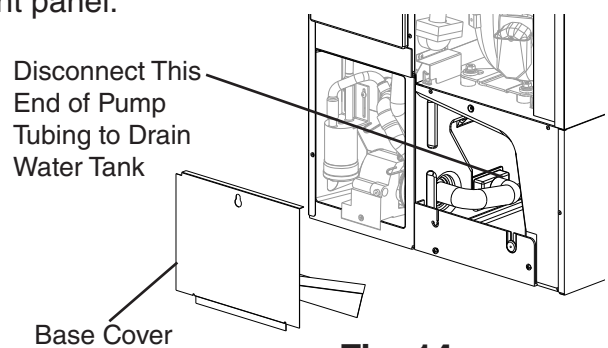

Fig. 14

- 5) Remove all ice from the dispensing unit/ice storage bin. Clean the storage bin liner using a neutral cleaner. Rinse thoroughly after cleaning.

3. On water-cooled model, remove the water from the water-cooled condenser:

- 1) Make sure the power supply is off, then remove the front panel and right side panel.
- 2) Close the condenser water supply line shut-off valve. If connected to a closed loop system, also close the condenser return line shut-off valve.
- 3) Open the condenser water supply line drain valve. If connected to a closed loop system, also open the condenser return line drain valve.
- 4) Attach a compressed air or carbon dioxide supply to the condenser water supply line drain valve.
- 5) Open the water regulating valve by using a screwdriver to pry up on the spring retainer underneath the spring. While holding the valve open, blow out the condenser using the compressed air or carbon dioxide supply until water stops coming out.
- 6) Close the drain valve(s).
- 7) Replace the right side panel and front panel in their correct positions.

VII. Disposal

The appliance contains refrigerant and must be disposed of in accordance with applicable national, state, and local codes and regulations. Refrigerant must be recovered by properly certified service personnel.

VIII. Technical Information

We reserve the right to make changes in specifications and design without prior notice.

A. Specification and Performance Data Sheets

Pressure data is recorded at 5 min. into freezing cycle. The data not in bold should be used for reference only.

1. KM-350MAJ

Specification Sheet

AC SUPPLY VOLTAGE	115/60/1	
AMPERAGE	9.05 A (5 Min. Freeze AT 104°F / WT 80°F)	
MINIMUM CIRCUIT AMPACITY	15 A	
MAXIMUM FUSE SIZE	15 A	
ELECTRIC & WATER CONSUMPTION	90/70°F	70/50°F
ELECTRIC W (kWH/100 lbs.)	890 (5.42)	810 (3.99)
WATER gal./24HR (gal./100 lbs.)	57 (14.5)	136 (27.8)
ICE PRODUCTION PER CYCLE	10.5 lbs. (4.8 kg) 480 pcs.	
BIN CONTROL SYSTEM	Ultra-Sonic Sensor	
REFRIGERANT CHARGE	R404A, 1 lb. 3.4 oz. (550g)	

Performance Data Sheet

APPROXIMATE ICE PRODUCTION PER 24 HR.	AMBIENT TEMP. (°F/°C)	WATER TEMP. (°F/°C)					
		50/10		70/21		90/32	
	70/21	489	<u>222</u>	461	<u>209</u>	437	<u>198</u>
	80/27	468	<u>212</u>	424	<u>192</u>	407	<u>185</u>
	90/32	461	<u>209</u>	393	<u>178</u>	372	<u>169</u>
lbs./day kg./day	100/38	461	<u>209</u>	388	<u>176</u>	353	<u>160</u>
APPROXIMATE ELECTRIC CONSUMPTION	70/21	810		833		888	
	80/27	828		864		931	
	90/32	833		890		953	
watts	100/38	852		905		1010	
APPROXIMATE WATER CONSUMPTION PER 24 HR.	70/21	136	<u>0.52</u>	113	<u>0.43</u>	103	<u>0.39</u>
	80/27	119	<u>0.45</u>	82	<u>0.31</u>	85	<u>0.32</u>
	90/32	113	<u>0.43</u>	57	<u>0.22</u>	54	<u>0.20</u>
gal./day m ³ /day	100/38	87	<u>0.33</u>	56	<u>0.21</u>	51	<u>0.19</u>
FREEZING CYCLE TIME	70/21	29		31		33	
	80/27	31		34		36	
	90/32	31		37		38	
min.	100/38	31		37		40	
HARVEST CYCLE TIME	70/21	3.1		2.8		2.7	
	80/27	2.9		2.3		2.4	
	90/32	2.8		2.0		2.0	
min.	100/38	2.4		2.0		2.0	
HEAD PRESSURE	70/21	233	<u>16.4</u>	249	<u>17.5</u>	278	<u>19.6</u>
	80/27	245	<u>17.2</u>	270	<u>19.0</u>	304	<u>21.4</u>
	90/32	249	<u>17.5</u>	287	<u>20.2</u>	320	<u>22.5</u>
PSIG kg/cm ² G	100/38	257	<u>18.1</u>	295	<u>20.7</u>	350	<u>24.6</u>
SUCTION PRESSURE	70/21	58	<u>4.1</u>	59	<u>4.1</u>	60	<u>4.2</u>
	80/27	58	<u>4.1</u>	59	<u>4.2</u>	60	<u>4.2</u>
	90/32	59	<u>4.1</u>	60	<u>4.2</u>	61	<u>4.3</u>
PSIG kg/cm ² G	100/38	59	<u>4.1</u>	60	<u>4.2</u>	62	<u>4.4</u>
TOTAL HEAT OF REJECTION FROM CONDENSER	5,700 BTU/h [AT 90°F (32°C) / WT 70°F (21°C)]						
TOTAL HEAT OF REJECTION FROM COMPRESSOR	1,000 BTU/h [AT 90°F (32°C) / WT 70°F (21°C)]						

2. KM-350MWJ

Specification Sheet

AC SUPPLY VOLTAGE	115/60/1	
AMPERAGE	7.5 A (5 Min. Freeze AT 104°F / WT 80°F)	
MINIMUM CIRCUIT AMPACITY	15 A	
MAXIMUM FUSE SIZE	15 A	
ELECTRIC & WATER CONSUMPTION	90/70°F	70/50°F
ELECTRIC W (kWH/100 lbs.)	780 (4.90)	770 (4.47)
WATER gal./24HR (gal./100 lbs.)	59 (15.5)	96 (23.2)
WATER COOLED CONDENSER	415 (109)	139 (34)
gal./24HR (gal./100 lbs.)		
ICE PRODUCTION PER CYCLE	10.5 lbs. (4.8 kg) 480pcs.	
BIN CONTROL SYSTEM	Ultra-Sonic Sensor	
REFRIGERANT CHARGE	R404A, 0 lb. 11.6 oz. (330g)	

Performance Data Sheet

APPROXIMATE ICE PRODUCTION PER 24 HR.	AMBIENT TEMP. (°F/°C)	WATER TEMP. (°F/°C)					
		50/10		70/21		90/32	
	70/21	414	<u>188</u>	405	<u>184</u>	390	<u>177</u>
	80/27	407	<u>185</u>	393	<u>178</u>	376	<u>171</u>
	90/32	405	<u>184</u>	383	<u>174</u>	366	<u>166</u>
lbs./day <u>kg/day</u>	100/38	401	<u>182</u>	379	<u>172</u>	351	<u>159</u>
APPROXIMATE ELECTRIC CONSUMPTION	70/21	770		773		774	
	80/27	772		777		776	
	90/32	773		780		780	
watts	100/38	772		780		780	
APPROXIMATE WATER CONSUMPTION PER 24 HR.	70/21	236	<u>0.89</u>	306	<u>1.16</u>	416	<u>1.57</u>
	80/27	289	<u>1.09</u>	398	<u>1.51</u>	516	<u>1.95</u>
	90/32	306	<u>1.16</u>	475	<u>1.80</u>	592	<u>2.24</u>
gal./day <u>m³/day</u>	100/38	417	<u>1.58</u>	502	<u>1.90</u>	699	<u>2.65</u>
FREEZING CYCLE TIME	70/21	34		35		36	
	80/27	35		36		37	
	90/32	35		37		38	
min.	100/38	35		37		38	
HARVEST CYCLE TIME	70/21	2.8		2.6		2.5	
	80/27	2.7		2.4		2.3	
	90/32	2.6		2.2		2.1	
min.	100/38	2.4		2.1		2.0	
HEAD PRESSURE	70/21	228	<u>16.0</u>	228	<u>16.0</u>	233	<u>16.4</u>
	80/27	228	<u>16.0</u>	228	<u>16.0</u>	235	<u>16.5</u>
	90/32	228	<u>16.0</u>	228	<u>16.0</u>	234	<u>16.5</u>
PSIG <u>kg/cm²G</u>	100/38	231	<u>16.2</u>	229	<u>16.1</u>	240	<u>16.9</u>
SUCTION PRESSURE	70/21	59	<u>4.1</u>	59	<u>4.2</u>	59	<u>4.2</u>
	80/27	59	<u>4.2</u>	60	<u>4.2</u>	60	<u>4.2</u>
	90/32	59	<u>4.2</u>	60	<u>4.2</u>	60	<u>4.2</u>
PSIG <u>kg/cm²G</u>	100/38	59	<u>4.2</u>	60	<u>4.2</u>	60	<u>4.2</u>
TOTAL HEAT OF REJECTION FROM CONDENSER	6,600 BTU/h [AT 90°F (32°C) / WT 70°F (21°C)]						
TOTAL HEAT OF REJECTION FROM COMPRESSOR	900 BTU/h [AT 90°F (32°C) / WT 70°F (21°C)]						
WATER FLOW FOR CONDENSER	27 gal./h [AT 100°F (38°C) / WT 90°F (32°C)]						

3. KM-420MAJ

Specification Sheet

AC SUPPLY VOLTAGE	115/60/1	
AMPERAGE	10.6 A (5 Min. Freeze AT 104°F / WT 80°F)	
MINIMUM CIRCUIT AMPACITY	20 A	
MAXIMUM FUSE SIZE	20 A	
ELECTRIC & WATER CONSUMPTION	90/70°F	70/50°F
ELECTRIC W (kWH/100 lbs.)	970(5.30)	860(4.05)
WATER gal./24HR (gal./100 lbs.)	75(17.0)	171(33.6)
ICE PRODUCTION PER CYCLE	10.3 lbs. (4.7 kg) 480pcs.	
BIN CONTROL SYSTEM	Ultra-Sonic Sensor	
REFRIGERANT CHARGE	R404A, 1 lb. 10.8 oz. (760g)	

Performance Data Sheet

APPROXIMATE ICE PRODUCTION PER 24 HR.	AMBIENT TEMP. (°F/°C)	WATER TEMP. (°F/°C)					
		50/10		70/21		90/32	
	70/21	508	<u>230</u>	488	<u>221</u>	456	<u>207</u>
	80/27	493	<u>224</u>	462	<u>210</u>	426	<u>193</u>
	90/32	488	<u>221</u>	440	<u>200</u>	405	<u>184</u>
lbs./day <u>kg./day</u>	100/38	480	<u>218</u>	432	<u>196</u>	373	<u>169</u>
APPROXIMATE ELECTRIC CONSUMPTION	70/21	860		892		922	
	80/27	885		935		957	
	90/32	892		970		996	
watts	100/38	893		976		1020	
APPROXIMATE WATER CONSUMPTION PER 24 HR.	70/21	171	<u>0.65</u>	142	<u>0.54</u>	129	<u>0.49</u>
	80/27	149	<u>0.56</u>	105	<u>0.40</u>	106	<u>0.40</u>
	90/32	142	<u>0.54</u>	75	<u>0.28</u>	69	<u>0.26</u>
gal./day <u>m³/day</u>	100/38	111	<u>0.42</u>	73	<u>0.28</u>	63	<u>0.24</u>
FREEZING CYCLE TIME	70/21	24		25		28	
	80/27	25		27		31	
	90/32	25		29		32	
min.	100/38	26		30		35	
HARVEST CYCLE TIME	70/21	3.4		3.0		2.9	
	80/27	3.1		2.4		2.6	
	90/32	3.0		2.0		2.0	
min.	100/38	2.6		2.0		2.0	
HEAD PRESSURE	70/21	200	<u>14.1</u>	218	<u>15.4</u>	248	<u>17.4</u>
	80/27	214	<u>15.1</u>	243	<u>17.1</u>	275	<u>19.3</u>
	90/32	218	<u>15.4</u>	263	<u>18.5</u>	295	<u>20.7</u>
PSIG <u>kg/cm²G</u>	100/38	226	<u>15.9</u>	270	<u>19.0</u>	324	<u>22.8</u>
SUCTION PRESSURE	70/21	46	<u>3.2</u>	49	<u>3.4</u>	52	<u>3.6</u>
	80/27	48	<u>3.4</u>	52	<u>3.7</u>	55	<u>3.9</u>
	90/32	49	<u>3.4</u>	55	<u>3.9</u>	58	<u>4.1</u>
PSIG <u>kg/cm²G</u>	100/38	49	<u>3.5</u>	56	<u>3.9</u>	61	<u>4.3</u>
TOTAL HEAT OF REJECTION FROM CONDENSER	6,600 BTU/h [AT 90°F (32°C) / WT 70°F (21°C)]						
TOTAL HEAT OF REJECTION FROM COMPRESSOR	1,100 BTU/h [AT 90°F (32°C) / WT 70°F (21°C)]						

4. KM-420MWJ

Specification Sheet

AC SUPPLY VOLTAGE	115/60/1	
AMPERAGE	8.45 A (5 Min. Freeze AT 104°F / WT 80°F)	
MINIMUM CIRCUIT AMPACITY	20 A	
MAXIMUM FUSE SIZE	20 A	
ELECTRIC & WATER CONSUMPTION	90/70°F	70/50°F
ELECTRIC W (kWH/100 lbs.)	850(4.70)	820(4.19)
WATER gal./24HR (gal./100 lbs.)	83(19.0)	145(30.8)
WATER COOLED CONDENSER	414(95)	214(45)
	gal./24HR (gal./100 lbs.)	
ICE PRODUCTION PER CYCLE	10.7 lbs. (4.8 kg) 480pcs.	
BIN CONTROL SYSTEM	Ultra-Sonic Sensor	
REFRIGERANT CHARGE	R404A, 0 lb. 12.7 oz. (360g)	

Performance Data Sheet

APPROXIMATE ICE PRODUCTION PER 24 HR.	AMBIENT TEMP. (°F/°C)	WATER TEMP. (°F/°C)					
		50/10		70/21		90/32	
	70/21	472	<u>214</u>	461	<u>209</u>	443	<u>201</u>
	80/27	464	<u>210</u>	447	<u>203</u>	428	<u>194</u>
	90/32	461	<u>209</u>	435	<u>197</u>	416	<u>189</u>
lbs./day kg./day	100/38	456	<u>207</u>	431	<u>195</u>	399	<u>181</u>
APPROXIMATE ELECTRIC CONSUMPTION	70/21	820		829		836	
	80/27	827		840		844	
	90/32	829		850		855	
watts	100/38	828		851		860	
APPROXIMATE WATER CONSUMPTION PER 24 HR.	70/21	359	<u>1.36</u>	400	<u>1.51</u>	473	<u>1.79</u>
	80/27	390	<u>1.48</u>	452	<u>1.71</u>	537	<u>2.03</u>
	90/32	400	<u>1.51</u>	496	<u>1.88</u>	578	<u>2.19</u>
gal./day m ³ /day	100/38	468	<u>1.77</u>	515	<u>1.95</u>	653	<u>2.47</u>
FREEZING CYCLE TIME	70/21	30		30		31	
	80/27	30		31		32	
	90/32	30		32		33	
min.	100/38	30		32		33	
HARVEST CYCLE TIME	70/21	3.1		2.8		2.7	
	80/27	2.9		2.4		2.5	
	90/32	2.8		2.0		2.0	
min.	100/38	2.5		2.0		2.0	
HEAD PRESSURE	70/21	284	<u>20.0</u>	284	<u>19.9</u>	282	<u>19.8</u>
	80/27	284	<u>20.0</u>	283	<u>19.9</u>	280	<u>19.7</u>
	90/32	284	<u>19.9</u>	283	<u>19.9</u>	280	<u>19.7</u>
PSIG kg/cm ² G	100/38	283	<u>19.9</u>	282	<u>19.9</u>	278	<u>19.5</u>
SUCTION PRESSURE	70/21	54	<u>3.8</u>	54	<u>3.8</u>	55	<u>3.9</u>
	80/27	54	<u>3.8</u>	55	<u>3.8</u>	56	<u>3.9</u>
	90/32	54	<u>3.8</u>	55	<u>3.9</u>	56	<u>3.9</u>
PSIG kg/cm ² G	100/38	55	<u>3.8</u>	55	<u>3.9</u>	57	<u>4.0</u>
TOTAL HEAT OF REJECTION FROM CONDENSER	6300 BTU/h [AT 90°F (32°C) / WT 70°F (21°C)]						
TOTAL HEAT OF REJECTION FROM COMPRESSOR	1100 BTU/h [AT 90°F (32°C) / WT 70°F (21°C)]						
WATER FLOW FOR CONDENSER	24.0378 gal./h [AT 100°F (38°C) / WT 90°F (32°C)]						

5. KM-420MRJZ with URC-5FZ

Specification Sheet

AC SUPPLY VOLTAGE	115/60/1	
AMPERAGE	12.05 A (5 Min. Freeze AT 104°F / WT 80°F)	
MINIMUM CIRCUIT AMPACITY	20 A	
MAXIMUM FUSE SIZE	20 A	
ELECTRIC & WATER CONSUMPTION	90/70°F	70/50°F
ELECTRIC W (kWH/100 lbs.)	960(5.00)	890(4.12)
WATER gal./24HR (gal./100 lbs.)	74(16.0)	158(30.3)
ICE PRODUCTION PER CYCLE	10.6 lbs. (4.8 kg) 480pcs.	
BIN CONTROL SYSTEM	Ultra-Sonic Sensor	
REFRIGERANT CHARGE	TOTAL R404A, 4 lb. 2.7 oz. (1890g)	
	ICEMAKER, 2 lb. 4.7 oz. (1040g)	
	CONDENSER, 1 lb. 14 oz. (850g)	

Performance Data Sheet

APPROXIMATE ICE PRODUCTION PER 24 HR.	AMBIENT TEMP. (°F/°C)	WATER TEMP. (°F/°C)					
		50/10		70/21		90/32	
	70/21	521	<u>236</u>	503	<u>228</u>	473	<u>215</u>
	80/27	508	<u>230</u>	479	<u>217</u>	447	<u>203</u>
	90/32	503	<u>228</u>	460	<u>208</u>	427	<u>194</u>
lbs./day kg./day	100/38	496	<u>225</u>	452	<u>205</u>	398	<u>180</u>
APPROXIMATE ELECTRIC CONSUMPTION	70/21	890		911		921	
	80/27	906		938		938	
	90/32	911		960		965	
watts	100/38	907		961		970	
APPROXIMATE WATER CONSUMPTION PER 24 HR.	70/21	158	<u>0.60</u>	133	<u>0.50</u>	121	<u>0.46</u>
	80/27	139	<u>0.53</u>	101	<u>0.38</u>	101	<u>0.38</u>
	90/32	133	<u>0.50</u>	74	<u>0.28</u>	69	<u>0.26</u>
gal./day m3/day	100/38	105	<u>0.40</u>	72	<u>0.27</u>	64	<u>0.24</u>
FREEZING CYCLE TIME	70/21	25		26		28	
	80/27	26		28		30	
	90/32	26		29		32	
min.	100/38	26		30		34	
HARVEST CYCLE TIME	70/21	3.4		3.0		2.9	
	80/27	3.1		2.5		2.6	
	90/32	3.0		2.0		2.0	
min.	100/38	2.6		2.0		2.0	
HEAD PRESSURE	70/21	207	<u>14.6</u>	223	<u>15.6</u>	249	<u>17.5</u>
	80/27	219	<u>15.4</u>	243	<u>17.1</u>	272	<u>19.1</u>
	90/32	223	<u>15.6</u>	260	<u>18.3</u>	289	<u>20.3</u>
PSIG kg/cm2G	100/38	230	<u>16.1</u>	267	<u>18.8</u>	315	<u>22.1</u>
SUCTION PRESSURE	70/21	50	<u>3.5</u>	50	<u>3.5</u>	53	<u>3.7</u>
	80/27	50	<u>3.5</u>	51	<u>3.6</u>	55	<u>3.9</u>
	90/32	50	<u>3.5</u>	51	<u>3.6</u>	55	<u>3.8</u>
PSIG kg/cm2G	100/38	52	<u>3.6</u>	52	<u>3.6</u>	58	<u>4.1</u>
TOTAL HEAT OF REJECTION FROM CONDENSER	6,200 BTU/h [AT 90°F (32°C) / WT 70°F (21°C)]						
TOTAL HEAT OF REJECTION FROM COMPRESSOR	1,000 BTU/h [AT 90°F (32°C) / WT 70°F (21°C)]						
CONDENSER VOLUME	44 CU. IN. URC-5FZ						

6. KM-520MAJ

Specification Sheet

AC SUPPLY VOLTAGE	115/60/1	
AMPERAGE	10.6 A (5 Min. Freeze AT 104°F / WT 80°F)	
MINIMUM CIRCUIT AMPACITY	20 A	
MAXIMUM FUSE SIZE	20 A	
ELECTRIC & WATER CONSUMPTION	90/70°F	70/50°F
ELECTRIC W (kWH/100 lbs.)	940 (4.68)	840 (3.64)
WATER gal./24HR (gal./100 lbs.)	71 (14.7)	180 (32.4)
ICE PRODUCTION PER CYCLE	10.3 lbs. (4.7 kg) 480pcs.	
BIN CONTROL SYSTEM	Ultra-Sonic Sensor	
REFRIGERANT CHARGE	R404A, 1 lb. 10.8 oz. (760g)	

Performance Data Sheet

APPROXIMATE ICE PRODUCTION PER 24 HR.	AMBIENT TEMP. (°F/°C)	WATER TEMP. (°F/°C)					
		50/10		70/21		90/32	
	70/21	556	<u>252</u>	534	<u>242</u>	497	<u>226</u>
	80/27	539	<u>245</u>	505	<u>229</u>	465	<u>211</u>
	90/32	534	<u>242</u>	480	<u>218</u>	441	<u>200</u>
lbs./day kg./day	100/38	524	<u>238</u>	471	<u>214</u>	405	<u>184</u>
APPROXIMATE ELECTRIC CONSUMPTION	70/21	840		869		891	
	80/27	862		908		919	
	90/32	869		940		956	
watts	100/38	867		944		970	
APPROXIMATE WATER CONSUMPTION PER 24 HR.	70/21	180	<u>0.68</u>	148	<u>0.56</u>	133	<u>0.50</u>
	80/27	156	<u>0.59</u>	106	<u>0.40</u>	107	<u>0.41</u>
	90/32	148	<u>0.56</u>	71	<u>0.27</u>	65	<u>0.25</u>
gal./day m ³ /day	100/38	112	<u>0.42</u>	69	<u>0.26</u>	59	<u>0.23</u>
FREEZING CYCLE TIME	70/21	24		25		28	
	80/27	25		27		31	
	90/32	25		29		32	
min.	100/38	26		30		35	
HARVEST CYCLE TIME	70/21	3.4		3.0		2.9	
	80/27	3.1		2.4		2.6	
	90/32	3.0		2.0		2.0	
min.	100/38	2.6		2.0		2.0	
HEAD PRESSURE	70/21	200	<u>14.1</u>	218	<u>15.4</u>	248	<u>17.4</u>
	80/27	214	<u>15.1</u>	243	<u>17.1</u>	275	<u>19.3</u>
	90/32	218	<u>15.4</u>	263	<u>18.5</u>	295	<u>20.7</u>
PSIG kg/cm ² G	100/38	226	<u>15.9</u>	270	<u>19.0</u>	324	<u>22.8</u>
SUCTION PRESSURE	70/21	46	<u>3.2</u>	49	<u>3.4</u>	52	<u>3.6</u>
	80/27	48	<u>3.4</u>	52	<u>3.7</u>	55	<u>3.9</u>
	90/32	49	<u>3.4</u>	55	<u>3.9</u>	58	<u>4.1</u>
PSIG kg/cm ² G	100/38	49	<u>3.5</u>	56	<u>3.9</u>	61	<u>4.3</u>
TOTAL HEAT OF REJECTION FROM CONDENSER	6,600 BTU/h [AT 90°F (32°C) / WT 70°F (21°C)]						
TOTAL HEAT OF REJECTION FROM COMPRESSOR	1,100 BTU/h [AT 90°F (32°C) / WT 70°F (21°C)]						

7. KM-520MWJ

Specification Sheet

AC SUPPLY VOLTAGE	115/60/1	
AMPERAGE	8.45 A (5 Min. Freeze AT 104°F / WT 80°F)	
MINIMUM CIRCUIT AMPACITY	20 A	
MAXIMUM FUSE SIZE	20 A	
ELECTRIC & WATER CONSUMPTION	90/70°F	70/50°F
ELECTRIC W (kWH/100 lbs.)	860 (4.65)	880 (4.45)
WATER gal./24HR (gal./100 lbs.)	66 (14.8)	114 (24.1)
WATER COOLED CONDENSER	333 (75)	149 (31)
gal./24HR (gal./100 lbs.)		
ICE PRODUCTION PER CYCLE	10.7 lbs. (4.8 kg) 480pcs.	
BIN CONTROL SYSTEM	Ultra-Sonic Sensor	
REFRIGERANT CHARGE	R404A, 0 lb. 12.7 oz. (360g)	

Performance Data Sheet

APPROXIMATE ICE PRODUCTION PER 24 HR.	AMBIENT TEMP. (°F/°C)	WATER TEMP. (°F/°C)					
		50/10		70/21		90/32	
	70/21	474	<u>215</u>	465	<u>211</u>	451	<u>204</u>
	80/27	467	<u>212</u>	454	<u>206</u>	438	<u>199</u>
	90/32	465	<u>211</u>	444	<u>201</u>	428	<u>194</u>
lbs./day <u>kg./day</u>	100/38	462	<u>209</u>	440	<u>200</u>	414	<u>188</u>
APPROXIMATE ELECTRIC CONSUMPTION	70/21	880		874		864	
	80/27	876		866		856	
	90/32	874		860		850	
watts	100/38	872		858		840	
APPROXIMATE WATER CONSUMPTION PER 24 HR.	70/21	263	<u>1.00</u>	303	<u>1.15</u>	376	<u>1.42</u>
	80/27	294	<u>1.11</u>	355	<u>1.34</u>	438	<u>1.66</u>
	90/32	303	<u>1.15</u>	399	<u>1.51</u>	479	<u>1.81</u>
gal./day <u>m³/day</u>	100/38	371	<u>1.40</u>	418	<u>1.58</u>	552	<u>2.09</u>
FREEZING CYCLE TIME	70/21	30		30		31	
	80/27	30		31		32	
	90/32	30		32		33	
min.	100/38	30		32		33	
HARVEST CYCLE TIME	70/21	3.1		2.8		2.7	
	80/27	2.9		2.4		2.5	
	90/32	2.8		2.0		2.0	
min.	100/38	2.5		2.0		2.0	
HEAD PRESSURE	70/21	284	<u>20.0</u>	284	<u>19.9</u>	282	<u>19.8</u>
	80/27	284	<u>20.0</u>	283	<u>19.9</u>	280	<u>19.7</u>
	90/32	284	<u>19.9</u>	283	<u>19.9</u>	280	<u>19.7</u>
PSIG <u>kg/cm²G</u>	100/38	283	<u>19.9</u>	282	<u>19.9</u>	278	<u>19.5</u>
SUCTION PRESSURE	70/21	54	<u>3.8</u>	54	<u>3.8</u>	55	<u>3.9</u>
	80/27	54	<u>3.8</u>	55	<u>3.8</u>	56	<u>3.9</u>
	90/32	54	<u>3.8</u>	55	<u>3.9</u>	56	<u>3.9</u>
PSIG <u>kg/cm²G</u>	100/38	55	<u>3.8</u>	55	<u>3.9</u>	57	<u>4.0</u>
TOTAL HEAT OF REJECTION FROM CONDENSER	6,300 BTU/h [AT 90°F (32°C) / WT 70°F (21°C)]						
TOTAL HEAT OF REJECTION FROM COMPRESSOR	2,100 BTU/h [AT 90°F (32°C) / WT 70°F (21°C)]						
WATER FLOW FOR CONDENSER	20 gal./h [AT 100°F (38°C) / WT 90°F (32°C)]						

8. KM-520MRJ with URC-5F

Specification Sheet

AC SUPPLY VOLTAGE	115/60/1	
AMPERAGE	12.05 A (5 Min. Freeze AT 104°F / WT 80°F)	
MINIMUM CIRCUIT AMPACITY	20 A	
MAXIMUM FUSE SIZE	20 A	
ELECTRIC & WATER CONSUMPTION	90/70°F	70/50°F
ELECTRIC W (kWH/100 lbs.)	990 (4.80)	920 (4.05)
WATER gal./24HR (gal./100 lbs.)	67 (13.6)	173 (31.6)
ICE PRODUCTION PER CYCLE	10.6 lbs. (4.8 kg) 480pcs.	
BIN CONTROL SYSTEM	Ultra-Sonic Sensor	
REFRIGERANT CHARGE	TOTAL R404A, 4 lb. 2.7 oz. (1890g) ICEMAKER, 2 lb. 4.7 oz. (1040g) CONDENSER, 1 lb. 14 oz. (850g)	

Performance Data Sheet

APPROXIMATE ICE PRODUCTION PER 24 HR.	AMBIENT TEMP. (°F/°C)	WATER TEMP. (°F/°C)					
		50/10		70/21		90/32	
	70/21	547	<u>248</u>	532	<u>241</u>	507	<u>230</u>
	80/27	535	<u>243</u>	512	<u>232</u>	484	<u>220</u>
	90/32	532	<u>241</u>	495	<u>225</u>	468	<u>212</u>
lbs./day kg./day	100/38	525	<u>238</u>	489	<u>222</u>	444	<u>201</u>
APPROXIMATE ELECTRIC CONSUMPTION	70/21	920		941		963	
	80/27	936		968		986	
	90/32	941		990		1011	
watts	100/38	943		995		1030	
APPROXIMATE WATER CONSUMPTION PER 24 HR.	70/21	173	<u>0.65</u>	142	<u>0.54</u>	129	<u>0.49</u>
	80/27	149	<u>0.57</u>	101	<u>0.38</u>	105	<u>0.40</u>
	90/32	142	<u>0.54</u>	67	<u>0.25</u>	64	<u>0.24</u>
gal./day m ³ /day	100/38	108	<u>0.41</u>	66	<u>0.25</u>	60	<u>0.23</u>
FREEZING CYCLE TIME	70/21	25		26		28	
	80/27	26		28		30	
	90/32	26		29		32	
min.	100/38	26		30		34	
HARVEST CYCLE TIME	70/21	3.4		3.0		2.9	
	80/27	3.1		2.5		2.6	
	90/32	3.0		2.0		2.0	
min.	100/38	2.6		2.0		2.0	
HEAD PRESSURE	70/21	207	<u>14.6</u>	223	<u>15.6</u>	249	<u>17.5</u>
	80/27	219	<u>15.4</u>	243	<u>17.1</u>	272	<u>19.1</u>
	90/32	223	<u>15.6</u>	260	<u>18.3</u>	289	<u>20.3</u>
PSIG kg/cm ² G	100/38	230	<u>16.1</u>	267	<u>18.8</u>	315	<u>22.1</u>
SUCTION PRESSURE	70/21	50	<u>3.5</u>	50	<u>3.5</u>	53	<u>3.7</u>
	80/27	50	<u>3.5</u>	51	<u>3.6</u>	55	<u>3.9</u>
	90/32	50	<u>3.5</u>	51	<u>3.6</u>	55	<u>3.8</u>
PSIG kg/cm ² G	100/38	52	<u>3.6</u>	52	<u>3.6</u>	58	<u>4.1</u>
TOTAL HEAT OF REJECTION FROM CONDENSER	6,200 BTU/h [AT 90°F (32°C) / WT 70°F (21°C)]						
TOTAL HEAT OF REJECTION FROM COMPRESSOR	1,000 BTU/h [AT 90°F (32°C) / WT 70°F (21°C)]						
CONDENSER VOLUME	44 CU. IN. URC-5F						

9. KM-520MRJZ with URC-5FZ

Specification Sheet

AC SUPPLY VOLTAGE	115/60/1	
AMPERAGE	12.05 A (5 Min. Freeze AT 104°F / WT 80°F)	
MINIMUM CIRCUIT AMPACITY	20 A	
MAXIMUM FUSE SIZE	20 A	
ELECTRIC & WATER CONSUMPTION	90/70°F	70/50°F
ELECTRIC W (kWH/100 lbs.)	990(4.80)	920(4.05)
WATER gal./24HR (gal./100 lbs.)	67(13.6)	173(31.6)
ICE PRODUCTION PER CYCLE	10.6 lbs. (4.8 kg) 480pcs.	
BIN CONTROL SYSTEM	Ultra-Sonic Sensor	
REFRIGERANT CHARGE	TOTAL R404A, 4 lb. 2.7 oz. (1890g)	
	ICEMAKER, 2 lb. 4.7 oz. (1040g)	
	CONDENSER, 1 lb. 14 oz. (850g)	

Performance Data Sheet

APPROXIMATE ICE PRODUCTION PER 24 HR.	AMBIENT TEMP. (°F/°C)	WATER TEMP. (°F/°C)					
		50/10		70/21		90/32	
	70/21	547	<u>248</u>	532	<u>241</u>	507	<u>230</u>
	80/27	535	<u>243</u>	512	<u>232</u>	484	<u>220</u>
	90/32	532	<u>241</u>	495	<u>225</u>	468	<u>212</u>
lbs./day kg./day	100/38	525	<u>238</u>	489	<u>222</u>	444	<u>201</u>
APPROXIMATE ELECTRIC CONSUMPTION	70/21	920		941		963	
	80/27	936		968		986	
	90/32	941		990		1011	
watts	100/38	943		995		1030	
APPROXIMATE WATER CONSUMPTION PER 24 HR.	70/21	173	<u>0.65</u>	142	<u>0.54</u>	129	<u>0.49</u>
	80/27	149	<u>0.57</u>	101	<u>0.38</u>	105	<u>0.40</u>
	90/32	142	<u>0.54</u>	67	<u>0.25</u>	64	<u>0.24</u>
gal./day m3/day	100/38	108	<u>0.41</u>	66	<u>0.25</u>	60	<u>0.23</u>
FREEZING CYCLE TIME	70/21	25		26		28	
	80/27	26		28		30	
	90/32	26		29		32	
min.	100/38	26		30		34	
HARVEST CYCLE TIME	70/21	3.4		3.0		2.9	
	80/27	3.1		2.5		2.6	
	90/32	3.0		2.0		2.0	
min.	100/38	2.6		2.0		2.0	
HEAD PRESSURE	70/21	207	<u>14.6</u>	223	<u>15.6</u>	249	<u>17.5</u>
	80/27	219	<u>15.4</u>	243	<u>17.1</u>	272	<u>19.1</u>
	90/32	223	<u>15.6</u>	260	<u>18.3</u>	289	<u>20.3</u>
PSIG kg/cm2G	100/38	230	<u>16.1</u>	267	<u>18.8</u>	315	<u>22.1</u>
SUCTION PRESSURE	70/21	50	<u>3.5</u>	50	<u>3.5</u>	53	<u>3.7</u>
	80/27	50	<u>3.5</u>	51	<u>3.6</u>	55	<u>3.9</u>
	90/32	50	<u>3.5</u>	51	<u>3.6</u>	55	<u>3.8</u>
PSIG kg/cm2G	100/38	52	<u>3.6</u>	52	<u>3.6</u>	58	<u>4.1</u>
TOTAL HEAT OF REJECTION FROM CONDENSER	6,200 BTU/h [AT 90°F (32°C) / WT 70°F (21°C)]						
TOTAL HEAT OF REJECTION FROM COMPRESSOR	1,000 BTU/h [AT 90°F (32°C) / WT 70°F (21°C)]						
CONDENSER VOLUME	44 CU. IN. URC-5FZ						

10. KM-660MAJ

Specification Sheet

AC SUPPLY VOLTAGE	115/60/1	
AMPERAGE	15.2 A (5 Min. Freeze AT 104°F / WT 80°F)	
MINIMUM CIRCUIT AMPACITY	20 A	
MAXIMUM FUSE SIZE	20 A	
ELECTRIC & WATER CONSUMPTION	90/70°F	70/50°F
ELECTRIC W (kWH/100 lbs.)	1320 (5.12)	1200 (4.34)
WATER gal./24HR (gal./100 lbs.)	91 (14.8)	204 (30.6)
ICE PRODUCTION PER CYCLE	10.7 lbs. (4.8 kg) 480pcs.	
BIN CONTROL SYSTEM	Ultra-Sonic Sensor	
REFRIGERANT CHARGE	R404A, 1 lb. 9.8 oz. (730g)	

Performance Data Sheet

APPROXIMATE ICE PRODUCTION PER 24 HR.	AMBIENT TEMP. (°F/°C)	WATER TEMP. (°F/°C)					
		50/10		70/21		90/32	
	70/21	665	<u>301</u>	650	<u>295</u>	627	<u>285</u>
	80/27	654	<u>297</u>	632	<u>287</u>	607	<u>275</u>
	90/32	650	<u>295</u>	617	<u>280</u>	591	<u>268</u>
lbs./day kg./day	100/38	645	<u>292</u>	611	<u>277</u>	569	<u>258</u>
APPROXIMATE ELECTRIC CONSUMPTION	70/21	1200		1235		1278	
	80/27	1227		1281		1321	
	90/32	1235		1320		1362	
watts	100/38	1242		1330		1400	
APPROXIMATE WATER CONSUMPTION PER 24 HR.	70/21	204	<u>0.77</u>	171	<u>0.65</u>	157	<u>0.59</u>
	80/27	178	<u>0.68</u>	127	<u>0.48</u>	131	<u>0.50</u>
	90/32	171	<u>0.65</u>	91	<u>0.35</u>	87	<u>0.33</u>
gal./day m ³ /day	100/38	134	<u>0.51</u>	90	<u>0.34</u>	84	<u>0.32</u>
FREEZING CYCLE TIME	70/21	20		21		23	
	80/27	21		22		24	
	90/32	21		24		25	
min.	100/38	21		24		27	
HARVEST CYCLE TIME	70/21	3.4		3.0		2.8	
	80/27	3.1		2.4		2.5	
	90/32	3.0		2.0		2.0	
min.	100/38	2.5		2.0		2.0	
HEAD PRESSURE	70/21	212	<u>14.9</u>	232	<u>16.3</u>	264	<u>18.5</u>
	80/27	227	<u>16.0</u>	257	<u>18.1</u>	292	<u>20.6</u>
	90/32	232	<u>16.3</u>	279	<u>19.6</u>	313	<u>22.0</u>
PSIG kg/cm ² G	100/38	240	<u>16.9</u>	287	<u>20.2</u>	345	<u>24.3</u>
SUCTION PRESSURE	70/21	37	<u>2.6</u>	39	<u>2.8</u>	46	<u>3.2</u>
	80/27	39	<u>2.7</u>	42	<u>3.0</u>	51	<u>3.6</u>
	90/32	39	<u>2.8</u>	45	<u>3.2</u>	53	<u>3.7</u>
PSIG kg/cm ² G	100/38	42	<u>2.9</u>	47	<u>3.3</u>	60	<u>4.2</u>
TOTAL HEAT OF REJECTION FROM CONDENSER	8,000 BTU/h [AT 90°F (32°C) / WT 70°F (21°C)]						
TOTAL HEAT OF REJECTION FROM COMPRESSOR	1,500 BTU/h [AT 90°F (32°C) / WT 70°F (21°C)]						

11. KM-660MWJ

Specification Sheet

AC SUPPLY VOLTAGE	115/60/1	
AMPERAGE	12.35 A (5 Min. Freeze AT 104°F / WT 80°F)	
MINIMUM CIRCUIT AMPACITY	20 A	
MAXIMUM FUSE SIZE	20 A	
ELECTRIC & WATER CONSUMPTION	90/70°F	70/50°F
ELECTRIC W (kWH/100 lbs.)	1190 (4.28)	1130 (4.07)
WATER gal./24HR (gal./100 lbs.)	107 (16.1)	194 (29.1)
WATER COOLED CONDENSER	1017 (152)	483 (72)
gal./24HR (gal./100 lbs.)		
ICE PRODUCTION PER CYCLE	10.8 lbs. (4.9 kg) 480pcs.	
BIN CONTROL SYSTEM	Ultra-Sonic Sensor	
REFRIGERANT CHARGE	R404A, 0 lb. 15.0 oz. (425g)	

Performance Data Sheet

APPROXIMATE ICE PRODUCTION PER 24 HR.	AMBIENT TEMP. (°F/°C)	WATER TEMP. (°F/°C)					
		50/10		70/21		90/32	
	70/21	669	<u>303</u>	669	<u>303</u>	644	<u>292</u>
	80/27	669	<u>303</u>	668	<u>303</u>	630	<u>286</u>
	90/32	669	<u>303</u>	668	<u>303</u>	635	<u>288</u>
lbs./day <u>kg./day</u>	100/38	655	<u>297</u>	661	<u>300</u>	605	<u>274</u>
APPROXIMATE ELECTRIC CONSUMPTION	70/21	1130		1148		1130	
	80/27	1143		1171		1130	
	90/32	1148		1190		1159	
watts	100/38	1130		1183		1130	
APPROXIMATE WATER CONSUMPTION PER 24 HR.	70/21	677	<u>2.56</u>	808	<u>3.06</u>	998	<u>3.78</u>
	80/27	777	<u>2.94</u>	981	<u>3.71</u>	1176	<u>4.45</u>
	90/32	808	<u>3.06</u>	1125	<u>4.26</u>	1322	<u>5.00</u>
gal./day <u>m³/day</u>	100/38	1010	<u>3.82</u>	1171	<u>4.43</u>	1503	<u>5.69</u>
FREEZING CYCLE TIME	70/21	19		19		19	
	80/27	19		20		19	
	90/32	19		20		19	
min.	100/38	19		20		19	
HARVEST CYCLE TIME	70/21	3.1		2.8		2.7	
	80/27	2.9		2.4		2.4	
	90/32	2.8		2.0		2.0	
min.	100/38	2.4		2.0		2.0	
HEAD PRESSURE	70/21	228	<u>16.0</u>	229	<u>16.1</u>	231	<u>16.2</u>
	80/27	228	<u>16.1</u>	229	<u>16.1</u>	232	<u>16.3</u>
	90/32	229	<u>16.1</u>	230	<u>16.2</u>	233	<u>16.4</u>
PSIG <u>kg/cm²G</u>	100/38	229	<u>16.1</u>	231	<u>16.2</u>	235	<u>16.5</u>
SUCTION PRESSURE	70/21	40	<u>2.8</u>	41	<u>2.9</u>	44	<u>3.1</u>
	80/27	41	<u>2.9</u>	43	<u>3.1</u>	46	<u>3.2</u>
	90/32	41	<u>2.9</u>	45	<u>3.2</u>	48	<u>3.3</u>
PSIG <u>kg/cm²G</u>	100/38	42	<u>3.0</u>	46	<u>3.2</u>	50	<u>3.5</u>
TOTAL HEAT OF REJECTION FROM CONDENSER	8,900 BTU/h [AT 90°F (32°C) / WT 70°F (21°C)]						
TOTAL HEAT OF REJECTION FROM COMPRESSOR	1,400 BTU/h [AT 90°F (32°C) / WT 70°F (21°C)]						
WATER FLOW FOR CONDENSER	59 gal./h [AT 100°F (38°C) / WT 90°F (32°C)]						

12. KM-660MRJ with URC-5F

Specification Sheet

AC SUPPLY VOLTAGE	115/60/1	
AMPERAGE	16.1 A (5 Min. Freeze AT 104°F / WT 80°F)	
MINIMUM CIRCUIT AMPACITY	20 A	
MAXIMUM FUSE SIZE	20 A	
ELECTRIC & WATER CONSUMPTION	90/70°F	70/50°F
ELECTRIC W (kWH/100 lbs.)	1400 (5.60)	1270 (4.72)
WATER gal./24HR (gal./100 lbs.)	88 (14.7)	213 (32.9)
ICE PRODUCTION PER CYCLE	10.4 lbs. (4.7 kg) 480pcs.	
BIN CONTROL SYSTEM	Ultra-Sonic Sensor	
REFRIGERANT CHARGE	TOTAL R404A, 4 lb. 2.7 oz. (1890g)	
	ICEMAKER, 2 lb. 4.7 oz. (1040g)	
	CONDENSER, 1 lb. 14 oz. (850g)	

Performance Data Sheet

APPROXIMATE ICE PRODUCTION PER 24 HR.	AMBIENT TEMP. (°F/°C)	WATER TEMP. (°F/°C)					
		50/10		70/21		90/32	
	70/21	646	<u>293</u>	633	<u>287</u>	612	<u>277</u>
	80/27	636	<u>289</u>	616	<u>279</u>	592	<u>269</u>
	90/32	633	<u>287</u>	602	<u>273</u>	578	<u>262</u>
lbs./day <u>kg./day</u>	100/38	628	<u>285</u>	596	<u>270</u>	557	<u>253</u>
APPROXIMATE ELECTRIC CONSUMPTION	70/21	1270		1308		1359	
	80/27	1299		1358		1409	
	90/32	1308		1400		1452	
watts	100/38	1318		1412		1500	
APPROXIMATE WATER CONSUMPTION PER 24 HR.	70/21	213	<u>0.80</u>	176	<u>0.67</u>	162	<u>0.61</u>
	80/27	185	<u>0.70</u>	128	<u>0.49</u>	134	<u>0.51</u>
	90/32	176	<u>0.67</u>	88	<u>0.33</u>	85	<u>0.32</u>
gal./day <u>m³/day</u>	100/38	136	<u>0.52</u>	87	<u>0.33</u>	82	<u>0.31</u>
FREEZING CYCLE TIME	70/21	20		21		22	
	80/27	20		22		24	
	90/32	21		23		25	
min.	100/38	21		24		26	
HARVEST CYCLE TIME	70/21	3.5		3.0		2.9	
	80/27	3.1		2.5		2.6	
	90/32	3.0		2.0		2.0	
min.	100/38	2.6		2.0		2.0	
HEAD PRESSURE	70/21	215	<u>15.1</u>	232	<u>16.3</u>	260	<u>18.3</u>
	80/27	228	<u>16.0</u>	254	<u>17.9</u>	285	<u>20.0</u>
	90/32	232	<u>16.3</u>	273	<u>19.2</u>	303	<u>21.3</u>
PSIG <u>kg/cm²G</u>	100/38	239	<u>16.8</u>	280	<u>19.7</u>	330	<u>23.2</u>
SUCTION PRESSURE	70/21	40	<u>2.8</u>	41	<u>2.9</u>	44	<u>3.1</u>
	80/27	41	<u>2.9</u>	43	<u>3.1</u>	46	<u>3.2</u>
	90/32	41	<u>2.9</u>	45	<u>3.2</u>	48	<u>3.3</u>
PSIG <u>kg/cm²G</u>	100/38	42	<u>3.0</u>	46	<u>3.2</u>	50	<u>3.5</u>
TOTAL HEAT OF REJECTION FROM CONDENSER	8,100 BTU/h [AT 90°F (32°C) / WT 70°F (21°C)]						
TOTAL HEAT OF REJECTION FROM COMPRESSOR	1,500 BTU/h [AT 90°F (32°C) / WT 70°F (21°C)]						
CONDENSER VOLUME	44 CU. IN. URC-5F						

13. KM-660MRJZ with URC-5FZ

Specification Sheet

AC SUPPLY VOLTAGE	115/60/1	
AMPERAGE	16.1 A (5 Min. Freeze AT 104°F / WT 80°F)	
MINIMUM CIRCUIT AMPACITY	20A	
MAXIMUM FUSE SIZE	20A	
ELECTRIC & WATER CONSUMPTION	90/70°F	70/50°F
ELECTRIC W (kWH/100 lbs.)	1250(5.25)	1160(4.34)
WATER gal./24HR (gal./100 lbs.)	86(15.0)	181(28.2)
ICE PRODUCTION PER CYCLE	10.4 lbs. (4.7 kg) 480pcs.	
BIN CONTROL SYSTEM	Ultra-Sonic Sensor	
REFRIGERANT CHARGE	TOTAL R404A, 4 lb. 2.7 oz. (1890g)	
	ICEMAKER, 2 lb. 4.7 oz. (1040g)	
	CONDENSER, 1 lb. 14 oz. (850g)	

Performance Data Sheet

APPROXIMATE ICE PRODUCTION PER 24 HR.	AMBIENT TEMP. (°F/°C)	WATER TEMP. (°F/°C)					
		50/10		70/21		90/32	
	70/21	642	<u>291</u>	621	<u>282</u>	577	<u>262</u>
	80/27	626	<u>284</u>	593	<u>269</u>	541	<u>245</u>
	90/32	621	<u>282</u>	570	<u>258</u>	520	<u>236</u>
lbs./day kg./day	100/38	607	<u>275</u>	558	<u>253</u>	474	<u>215</u>
APPROXIMATE ELECTRIC CONSUMPTION	70/21	1160		1186		1218	
	80/27	1180		1221		1251	
	90/32	1186		1250		1281	
watts	100/38	1191		1257		1310	
APPROXIMATE WATER CONSUMPTION PER 24 HR.	70/21	181	<u>0.69</u>	153	<u>0.58</u>	136	<u>0.52</u>
	80/27	160	<u>0.60</u>	116	<u>0.44</u>	112	<u>0.42</u>
	90/32	153	<u>0.58</u>	86	<u>0.32</u>	76	<u>0.29</u>
gal./day m3/day	100/38	120	<u>0.46</u>	83	<u>0.32</u>	66	<u>0.25</u>
FREEZING CYCLE TIME	70/21	21		22		25	
	80/27	22		24		27	
	90/32	22		25		28	
min.	100/38	23		26		30	
HARVEST CYCLE TIME	70/21	3.2		2.8		2.7	
	80/27	2.9		2.3		2.4	
	90/32	2.8		2.0		2.0	
min.	100/38	2.4		2.0		2.0	
HEAD PRESSURE	70/21	219	<u>15.4</u>	238	<u>16.7</u>	261	<u>18.4</u>
	80/27	234	<u>16.4</u>	263	<u>18.5</u>	285	<u>20.0</u>
	90/32	238	<u>16.7</u>	284	<u>20.0</u>	307	<u>21.6</u>
PSIG kg/cm2G	100/38	242	<u>17.0</u>	289	<u>20.3</u>	328	<u>23.1</u>
SUCTION PRESSURE	70/21	44	<u>3.1</u>	46	<u>3.2</u>	50	<u>3.5</u>
	80/27	46	<u>3.2</u>	49	<u>3.4</u>	53	<u>3.7</u>
	90/32	46	<u>3.2</u>	51	<u>3.6</u>	55	<u>3.9</u>
PSIG kg/cm2G	100/38	47	<u>3.3</u>	52	<u>3.7</u>	59	<u>4.1</u>
TOTAL HEAT OF REJECTION FROM CONDENSER	8,100 BTU/h [AT 90°F (32°C) / WT 70°F (21°C)]						
TOTAL HEAT OF REJECTION FROM COMPRESSOR	1,500 BTU/h [AT 90°F (32°C) / WT 70°F (21°C)]						
CONDENSER VOLUME	44 CU. IN. URC-5FZ						

B. Wiring Diagrams

1. K Control Board (2A8242-02) with Ultrasonic Bin Control

Ultrasonic Bin Control Board (4A6838-01)

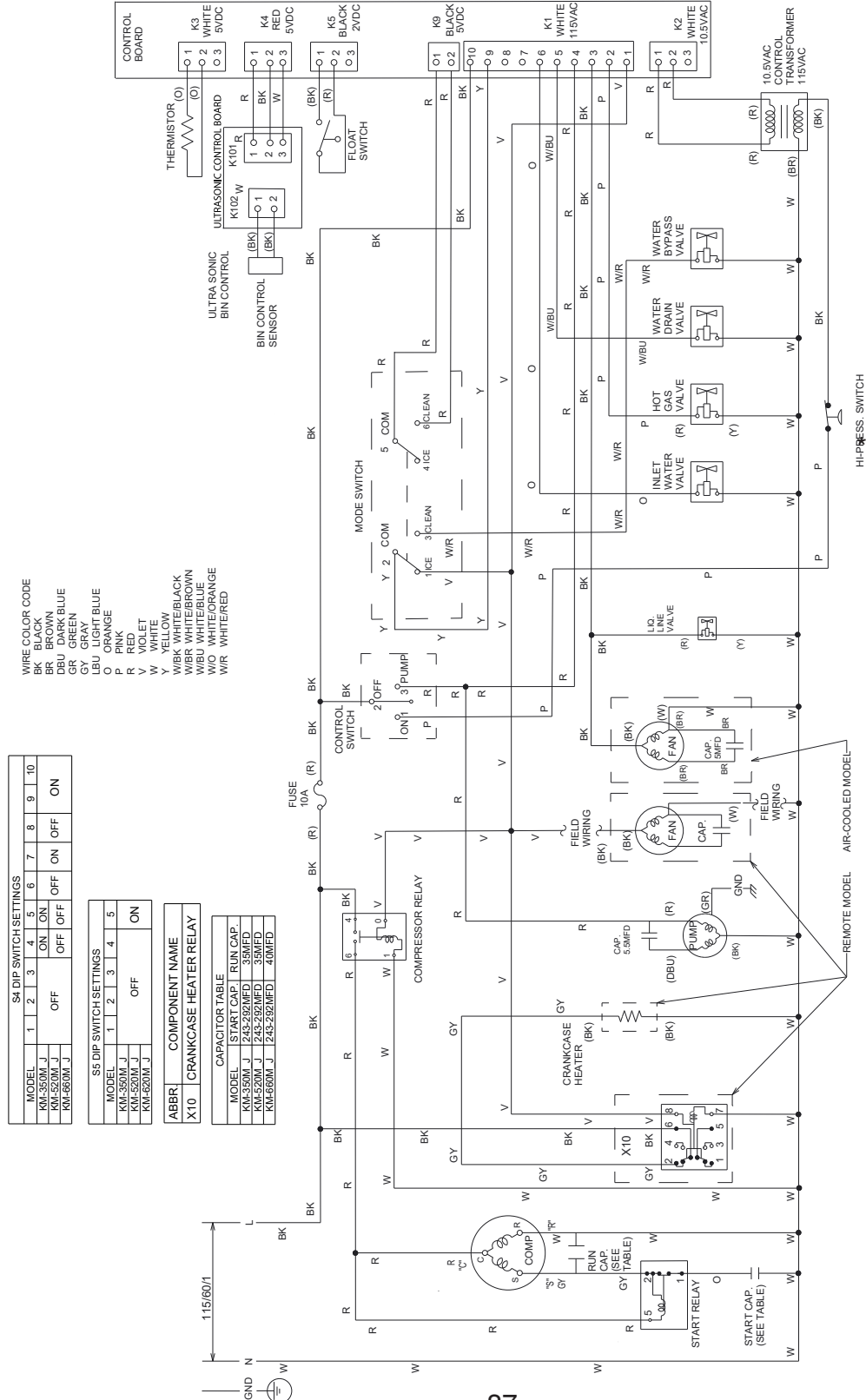

* High-Pressure Switch	
Water-Cooled Model	Air and Remote Models
Cut-out	384±22 PSIG
Cut-in	284±22 PSIG
	412±22 PSIG
	327±22 PSIG

2. K Control Board (2A8242-02) with Mechanical Bin Control

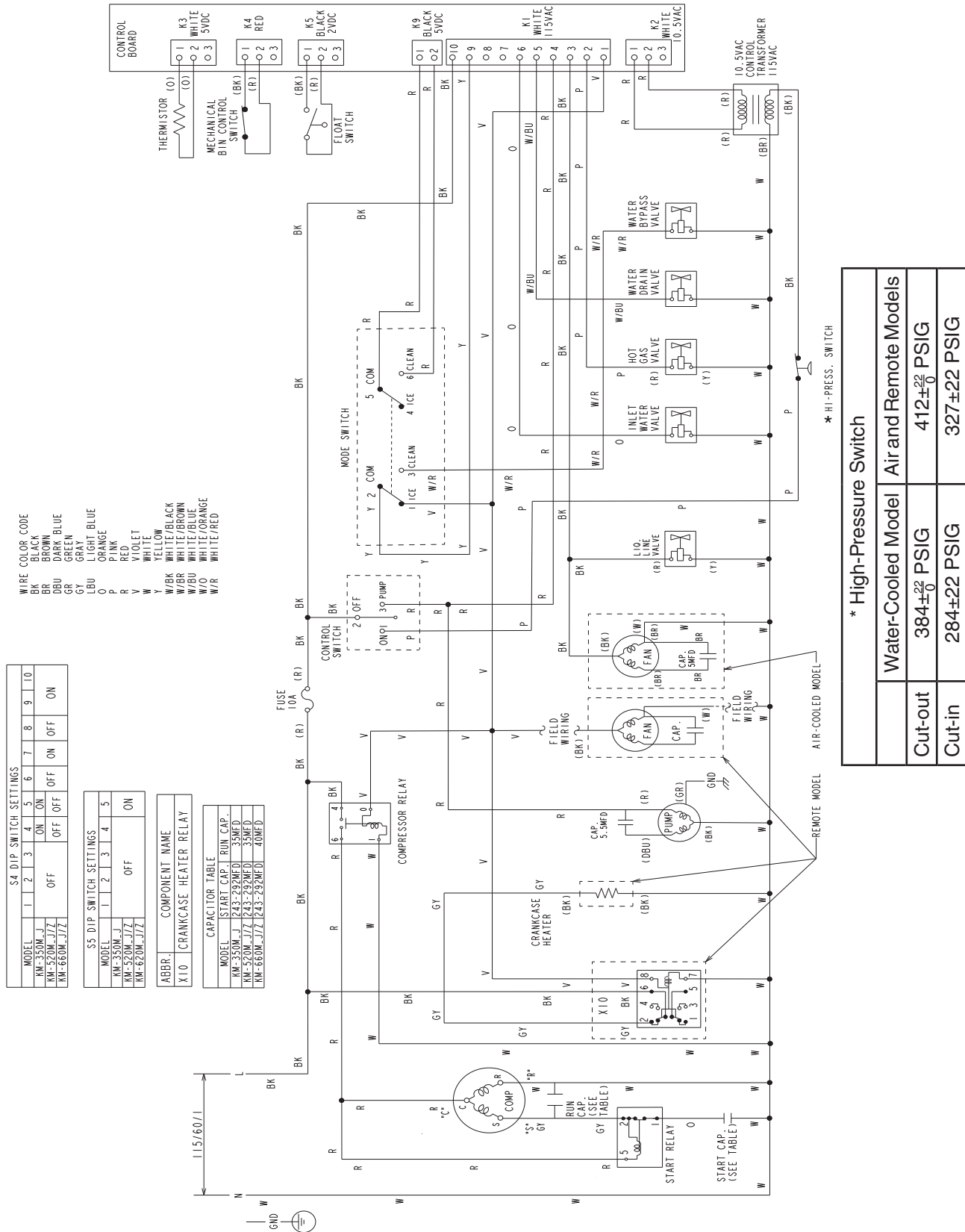

3. K+ Control Board (2A9678-01) with Ultrasonic Bin Control

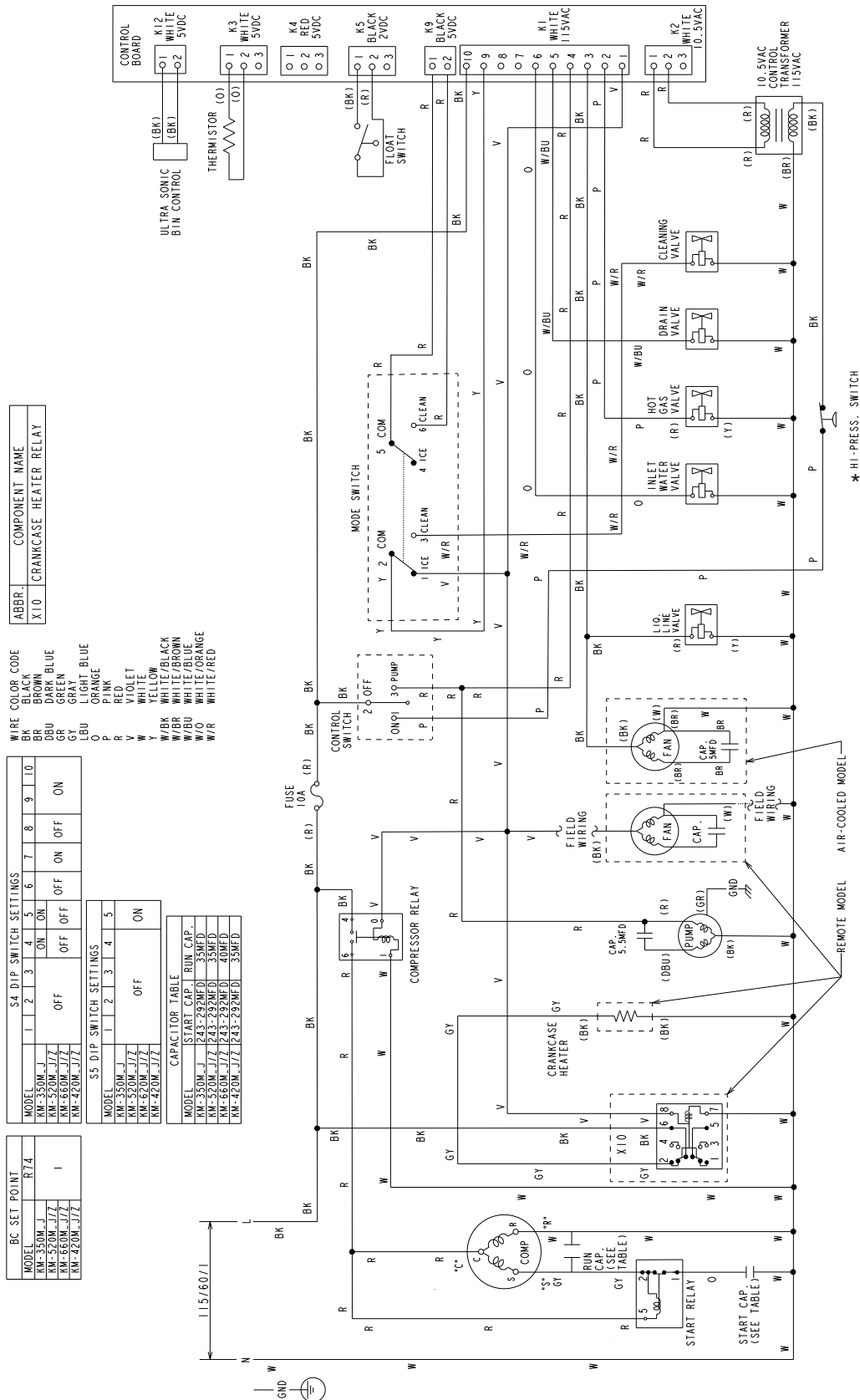

* High-Pressure Switch		
Water-Cooled Model	Air and Remote Models	
Cut-out	384±22 PSIG	412±22 PSIG
Cut-in	284±22 PSIG	327±22 PSIG