



Project _____
 AIA # _____ SIS # _____
 Item # _____ Quantity _____ C.S.I. Section 114000



LXGnR advansys ENERGY RECOVERY Glass Washing Machine



LXGnR with 6" Stand



STANDARD FEATURES

- + Racks per hour – Light 30 / Normal 24
- + .62 gallons of water per cycle
- + High temperature sanitization unit
- + Steam elimination and energy recovery
- + AutoClean cycle washes down inside of machine at shutdown
- + User-friendly smart touchscreen controls
- + Wi-Fi connectivity
- + SmartConnect App with machine status, temperature logs, error code reporting, and usage analysis
- + Temperature and chemical alerts (lockouts available)
- + Sense-A-Temp™ 70°F rise electric booster heater
- + Chemical pumps with auto-prime for detergent and rinse aid
- + Soft start to protect glassware
- + Auto delime cycle with auto dispensing and booster assurance
- + Deep drawn stainless steel tank
- + Revolving upper and lower anti-clogging interchangeable wash arms
- + Snap-in revolving upper and lower interchangeable rinse arms
- + 2-stage wash tank filtration
- + Energy saver mode
- + Automatic pumped rinse and drain
- + 12" door opening
- + Automatic fill
- + Electric tank heat
- + One glass/wine rack
- + 6" leg stand (ships with LXGnR-2)
- + 14" leg stand (ships with LXGnR-1)

SPECIFIER STATEMENT

Specified unit will be a NSF rated Advansys under-counter glasswasher with hot water sanitization. Features up to 30 racks per hour, .62 gallons per cycle, AutoClean, 12" door opening, color touchscreen with Wi-Fi and SmartConnect App connectivity, low temperature and chemical alerts, advanced diagnostics and service connection, rinse aid, detergent and delime pumps. Constructed of stainless steel.

1-year parts and labor warranty.

OPTIONS & ACCESSORIES (Available at extra cost)

- Power cord kit
- Drain water tempering kit
- Splash reduction panel
- Door lock (prevents door from opening until completion of cycle)
- Trim strip
- External height adjustable casters
- Internal height adjustable casters (3")
- Water hammer arrestor kit
- Pumped drain air gap kit

LXGnR SERIES – LXGnR advansys ENERGY RECOVERY

Approved by _____ Date _____ Approved by _____ Date _____



LXGnR advansys ENERGY RECOVERY Glass Washing Machine (On Feet)

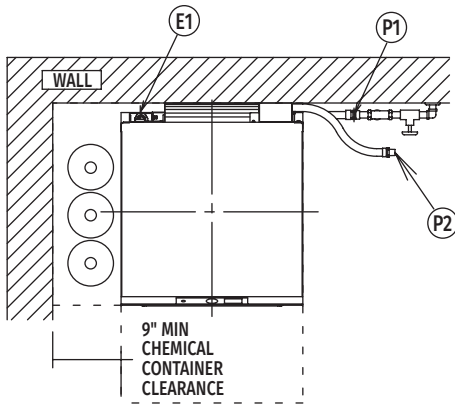

Top View

LEGEND

Electrical Connections	
E1	Electrical connection: 1-3/8" dia. hole for 1" trade size conduit; 10-5/8" AFF (18-1/8" AFF with 14" stand).
Plumbing Connections	
P1	Single fill and rinse connection: 3/4" female garden hose fitting on 6' long hose supplied with machine; 55-85° F (cold) recommended for LXGnR.
P2	Common drain connection: 5/8" barb fitting with 6' long hose supplied with machine.

WARNING: Electrical and grounding connections must comply with the applicable portions of the National Electrical Code and/or other local electrical codes.

Plumbing connections must comply with applicable sanitary, safety and plumbing codes. Drain and fill line configurations vary, some methods are shown on this drawing.

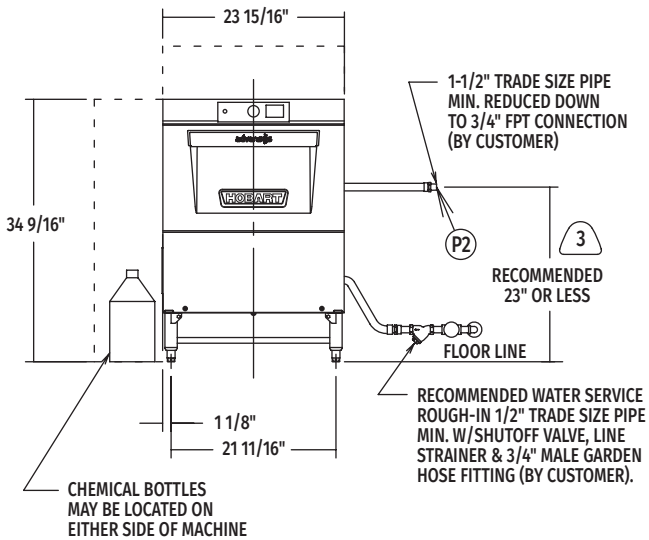

Front View on Feet

(E1) STANDARD ELECTRICAL OPTIONS

Tank Heat, Booster, Pump & Controls			
Voltage	Rated Amps	Minimum Supply Circuit Ampacity	Maximum Protective Device
120/208(3W)/60/1*	23.7	30	30
120/208-240(3W)/60/1*	34.0	40	40

NOTE: For supply connections, use copper wire only rated at 90°C minimum.

*This system requires three power wires which includes a current carrying neutral, an additional fourth wire must be provided for machine ground.

Dishmachine not provided with internal GFCI protection.

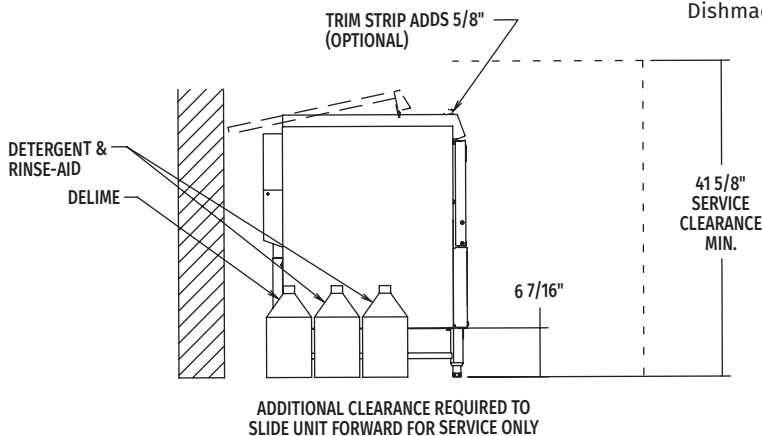

Left Side View on Feet

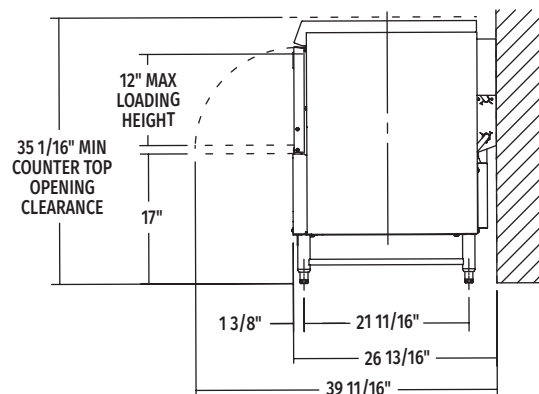

Right Side View on Feet

MODEL:
LXGnR FOOT
00-563662
REV: A3

CAD and/or Revit Files Available



LXGnR advansys ENERGY RECOVERY

Glass Washing Machine

(With 14" Leg Stand)

SPECIFICATIONS

Capacities

Cycle Time (seconds) Light 119 / Normal 148
 Racks per Hour Light 30 / Normal 24
 Tank Capacity – Gallons 2.9

Motor Horsepower

Wash 0.85
 Rinse 0.19

Water Consumption

U.S. Gallons per Cycle 0.62
 U.S. Gallons per Hour (maximum use) 18.6
 Peak Drain Flow – U.S. Gallons 4.0

Temperatures °F

Wash 150
 Rinse 180
 Incoming Water Temperature
 (minimum recommended) 55-85

Heating

Tank Heat, electric (kW) 1.8
 Electric Booster (kW) 4.9

Standard 20" x 20" Rack Complement

Wine/glass 1

Shipping Weight (approximate) 215 lbs.

Crated Dimensions

With 6" Leg Stand 34"W x 24"L x 27"H
 With 14" Leg Stand 42"W x 24"L x 27"H

Heat Output, BTU/Hour	
Latent	Sensible
1,100	2,000

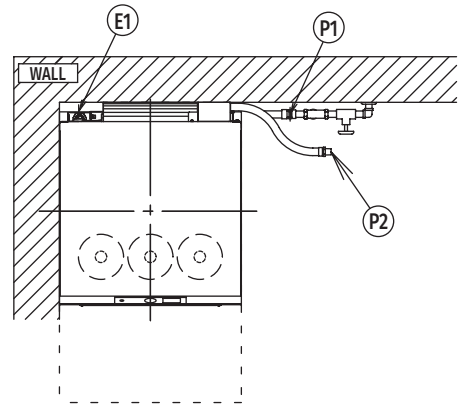

Top View

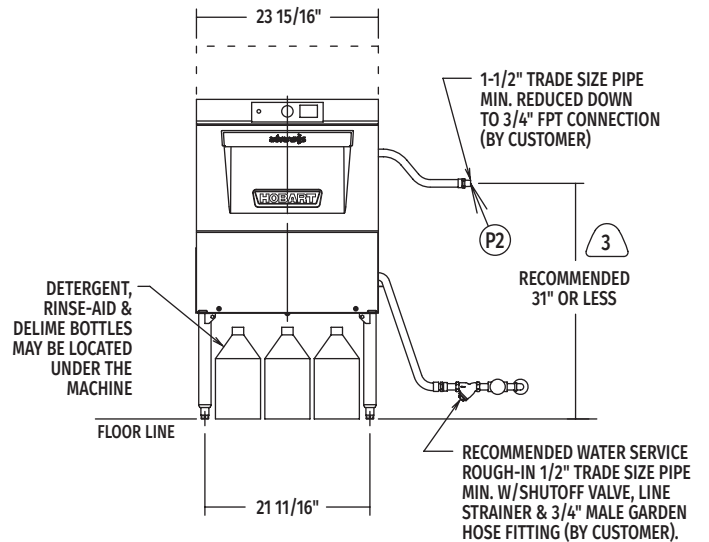

Front View with 14" Leg Stand

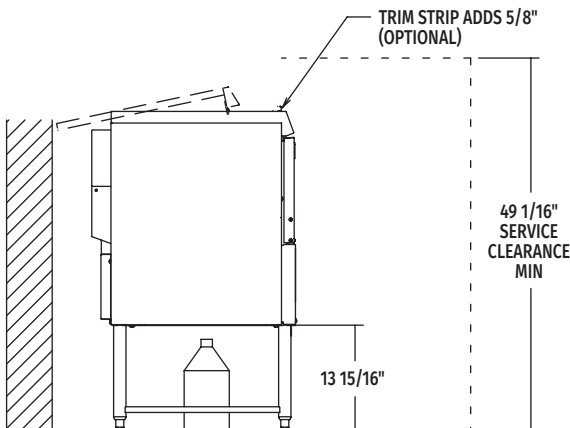

ADDITIONAL CLEARANCE REQUIRED TO SLIDE UNIT FORWARD FOR SERVICE ONLY

Left Side View with 14" Leg Stand

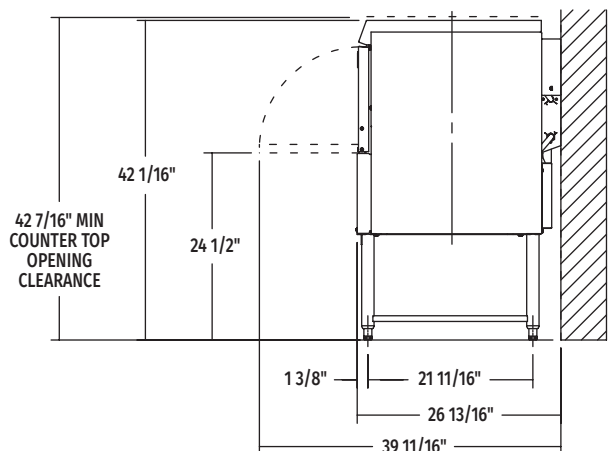

Right Side View with 14" Leg Stand

MODEL:
 LXGnR TALL
 00-563662
 REV: A3

CAD and/or Revit Files Available



LXGnR advansys ENERGY RECOVERY Glass Washing Machine

NOTICE

Required flowing water pressure to the dishmachine is 15-65 PSIG. If pressures higher than 65 PSIG are present, a pressure regulating valve must be installed in the water line to the dishmachine (by others).

Pressure gauge not required on pumped rinse machines.

Important: The chemical containers should be placed no higher than 16" above floor (24" above floor with 14" stand).

If chemical containers are to be placed in cabinet adjacent to machine, a 1/2" dia. hole is required in the cabinet to run chemical supply line.

Notes:

1. All vertical machine dimensions taken from floor may be increased by 1/2" or decreased by 3/8".
2. Moist air escapes from the door.
Use only moisture resistant materials adjacent to dishmachine sides and top.
3. A vent hood is not recommended above the undercounter dishmachine since it does not produce excessive vapors.

Plumbing Notes:

1. Water hammer arrestor (meeting ASSE-1010 Standard or equivalent) to be supplied (by others) in common water supply line at service connection.
2. Recommended water hardness to be 3 grains or less for best results.
3. If drain hose is looped above a sink, the loop must not exceed 44" AFF (51" AFF with 14" stand).
4. Backflow prevention provided by NSF-approved air gap device.