

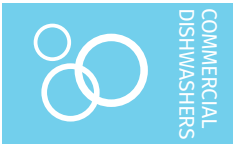

Project _____
 AIA # _____ SIS # _____
 Item # _____ Quantity _____ C.S.I. Section 114000

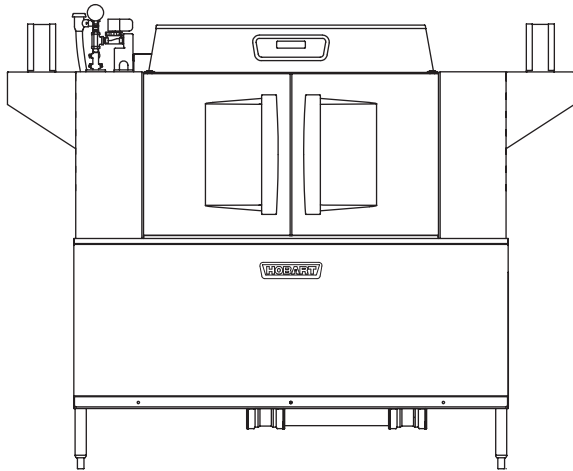

CL64eN-BAS ELECTRIC High Temperature Rack Conveyor Dishwashing Machine



SPECIFIER STATEMENT

Specified dishwasher will be Hobart CL64eN Base electric tank heat model with Opti-Rinse™. Includes 342 racks per hour capacity, dirty water indicator, configurable “intelligent” de-lime notification, top mounted computer controls, and NSF approved pot and pan cycle mode. The wash tank utilizes durable precision pressure sensor monitors in lieu of conventional mechanical floats. The 19.5" standard chamber height will accommodate up to (6) standard sheet pans at a time on an open-end sheet pan rack.

STANDARD FEATURES

- + 342 racks per hour
- + Opti-Rinse™ system
- + Rapid return conveyor drive mechanism
- + Large double door opening for ease of cleaning
- + Doors are insulated & hinged with door interlock switches
- + 19.5" chamber height opening (accepts sheet pans)
- + Top mounted micro-processor control module
- + Energy saver mode (programmable auto-shut down)
- + Dirty water indicator
- + Manager activated low temperature alert
- + NSF rated configurable pot and pan dwell mode
- + Configurable “intelligent” de-lime notification
- + Service diagnostics
- + Self-aligning wash manifolds
- + Stainless steel anti-clogging wash arms
- + Removable pump intake screen
- + Stainless steel self-draining pump and impeller
- + Single, sloping scrap screen and deep scrap basket
- + Stainless panels enclose perimeter and bottom
- + Door actuated drain closure
- + Convertible hot water or low temp final rinse
- + Vent fan control
- + Booster heater control
- + ENERGY STAR® Certified

OPTIONS & ACCESSORIES (Available at extra cost)

- Standard, short, and extended stainless steel vent hoods
- Internal stainless steel pressure-less 30 kW booster heater field convertible to 15 kW (booster includes PRV)
- Direct drive unloader – adds 38" length. Reference spec F39520 for more details
- Side loader – SL23 adds 23" length, SL30 adds 30" length. Reference specs F40926 and F40927 for more details
- Blower-dryer – adds 33¾" to length. Reference spec F40252 for more details (ships separate from dishmachine, contact Hobart Service for installation)
- Drain water tempering kit (field installed)
- Flanged feet kit (requires two kits)
- Higher than standard chamber (24" opening)
- Table limit switch with 10' wire
- Correctional package (contact Hobart for details)
- Pressure regulator valve (PRV), for use with external booster
- Water shock absorber kit
- Factory-mounted circuit breakers (contact Hobart for details)
- Common electrical connection (see page 4)

CLEAN SERIES – CL64eN-BAS ELECTRIC

Approved by _____ Date _____ Approved by _____ Date _____



CL64eN-BAS ELECTRIC

High Temperature Rack Conveyor Dishwashing Machine

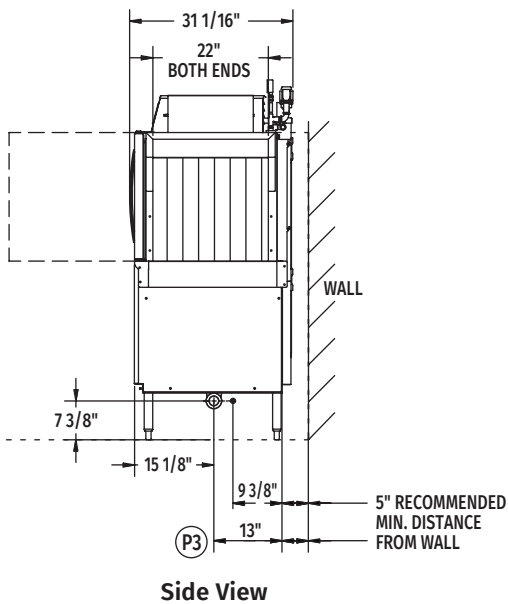
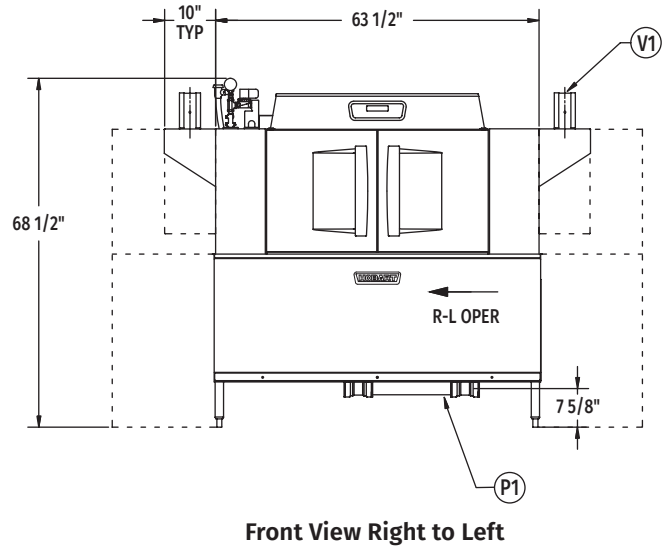
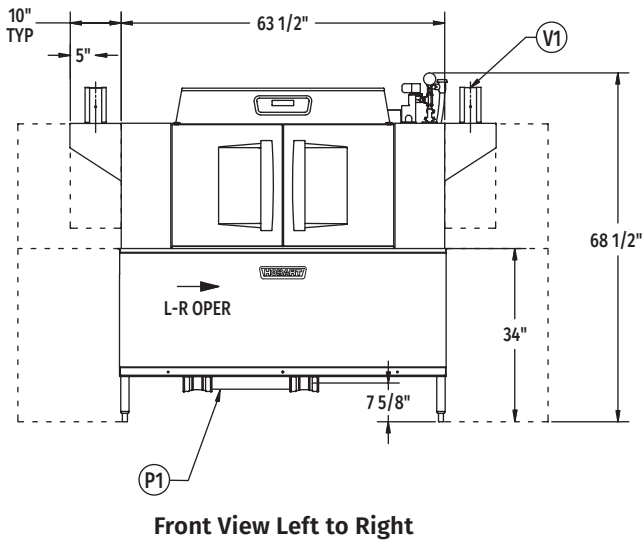
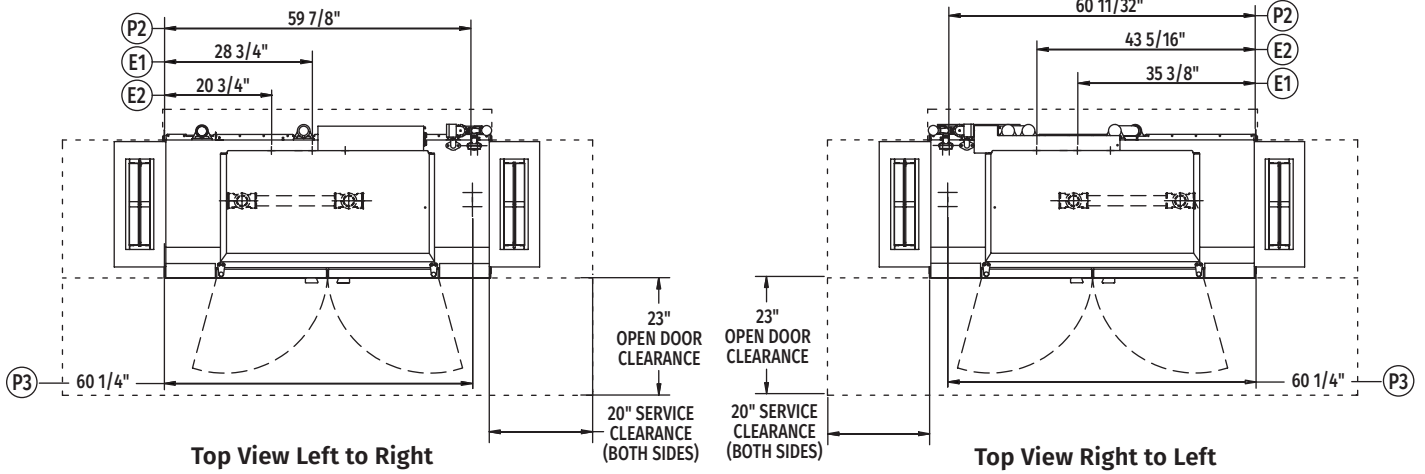

Tabling Connection: 64" inside tank (at table connection)

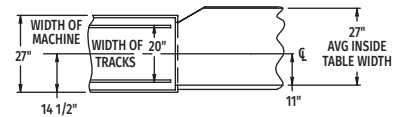

Suggested Track and Table Layout

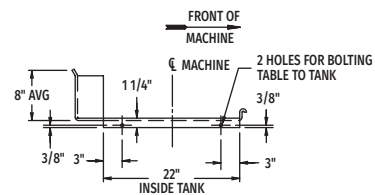

View Showing Hole Locations in Turned Down Portion of Table

MODEL- CL64eN BASE
L-R OPERATION
D-974805
REV B

MODEL- CL64eN BASE
R-L OPERATION
D-974804
REV B



CL64eN-BAS ELECTRIC

High Temperature Rack Conveyor Dishwashing Machine

LEGEND

Electrical Connections	
E1	Motors, controls, and electric tank heat 1-1/4" or 2" conduit, 63-3/4" AFF.
E2	Internal electric booster 1-1/4" or 2" conduit, 63-3/4" AFF.
NOTE: Common electrical connection (single point) available, see page 4 for details.	
Plumbing Connections	
P1	Drain. May be drained to either side of valve, plug opposite side 2" FPT. Recommend a floor drain minimum of 12" from machine for access and maintenance. 7-3/8" AFF.
P2	Hot water. 1/2" FPT connection. 1/2", 11-3/16" AFF. See plumbing notes for required temperatures.
P3	Optional cold water connection for drain water tempering 1/2" FPT, cold water temperature 80°F, maximum 7-3/8" AFF.
Vent Connections	
V1	Optional vent hoods, 4" x 16" vent stack with damper.

SPECIFICATIONS

Capacities

Racks Per Hour (NSF rated)	342
Wash Tank (U.S. gallons).	23
Rinse Tank (U.S. gallons)	22
Conveyor Speed (feet per minute).	9.5

Motor Horsepower

Drive	1/6
Wash2
Rinse2

Water Consumption

U.S. Gallons per Hour (maximum use at 20 PSI).	132
U.S. Gallons per Rack	0.39
Peak Drain Flow (U.S. gallons per minute).	38

Heating

Tank Heat, Electric (kW)	25
Optional Electric Booster (built-in) (kW for 40°F rise).	15
Optional Electric Booster (built-in) (kW for 70°F rise).	30

Venting

Load End (minimum CFM).	200
Unload End (minimum CFM).	400

Shipping Weight (approximate)840 lbs.

Crated Dimensions.74"L x 38"W x 78"H

E1	Electrical Connection (3 PH only) Motors, Controls and Electric Tank Heat			
	Voltage	Rated Amps	Minimum Supply Circuit Ampacity	Maximum Protective Device
	208/60/3	90.6	125	125
	240/60/3	86.6	125	125
	480/60/3	44.9	60	60
	600/60/3	32.2	45	45
NOTE: Electric tank heat can be split from motors & controls, see page 4 for details.				

Dishmachine not provided with internal GFCI protection.

NOTE: Additional CLeN Voltages and Amperages are available, see document F40972.

WARNING: Plumbing and electrical connections should be made by qualified personnel who will observe all the applicable plumbing, sanitary, safety codes and National Electrical Code.

Plumbing Notes: Minimum incoming water temperatures: 110°F for 30kW internal booster, 140°F for 15kW field converted internal booster, 180°F without internal booster. Building flowing water pressure to dish machine is 20 PSI, (+/- 5 PSI). For non-booster machines, a PRV with internal expansion bypass is required.

Recommended water hardness to be 3 grains or less for best results.

E2	Booster Heat 30 kW (Standard) Minimum 110°F Incoming Water			
	Voltage	Rated Amps	Minimum Supply Circuit Ampacity	Maximum Protective Device
	208/60/3	83.9	90	90
	240/60/3	80.2	90	90
	480/60/3	40.1	50	50
	600/60/3	26.9	40	40

E2	Booster Heat 15 kW (Field Convertible) Minimum 140°F Incoming Water			
	Voltage	Rated Amps	Minimum Supply Circuit Ampacity	Maximum Protective Device
	208/60/3	45.0	60	60
	240/60/3	40.1	50	50
	480/60/3	20.0	25	25
	600/60/3	13.5	20	20

CL64eN-BAS Electric Heat Dissipation		
Booster	BTU/HR.	
	Latent	Sensible
Without Booster	24,800	10,600
15kW Booster	38,400	16,400
30kW Booster	51,900	22,200



CL64eN-BAS ELECTRIC

High Temperature Rack Conveyor Dishwashing Machine

COMMON ELECTRICAL CONNECTION (SINGLE POINT) – CONTACT FACTORY FOR ADDITIONAL INFORMATION

Common Electrical Connection (Includes Motors & Controls, Electric Wash Tank Heat, Electric Rinse Tank Heat & Electric Booster Heater)						
Voltage	MACHINE AND 15kW BOOSTER			MACHINE AND 30kW BOOSTER		
	Rated Amps	Minimum Supply Circuit Ampacity	Maximum Protective Device	Rated Amps	Minimum Supply Circuit Ampacity	Maximum Protective Device
208/60/3	136	150	150	175	200	200
240/60/3	127	150	150	167	200	200
480/60/3	65	80	80	85	100	100
600/60/3	45.7	65	65	59.1	85	85

FIELD CONVERTIBLE SERVICE CONNECTIONS

At time of installation, service connections for motors, controls, and electric tank heat can be split as necessary for installation.

Separate Service Connection for Wash Tank			
Voltage	Rated Amps	Minimum Supply Circuit Ampacity	Maximum Protective Device
208/60/3	45.0	60	60
240/60/3	43.0	60	60
480/60/3	22.0	30	30
600/60/3	14.4	20	20

Separate Service Connection for Motors & Controls			
Voltage	Rated Amps	Minimum Supply Circuit Ampacity	Maximum Protective Device
208/60/3	15.6	20	20
240/60/3	15.1	20	20
480/60/3	9.1	20	20
600/60/3	8.2	15	15

Separate Service Connection for 10 kW Rinse Tank			
Voltage	Rated Amps	Minimum Supply Circuit Ampacity	Maximum Protective Device
208/60/3	30.0	40	40
240/60/3	28.6	40	40
480/60/3	14.3	20	20
600/60/3	9.6	15	15

NOTE: Additional CLeN Voltages and Amperages are available, see document F40972.

VENT HOOD OPTIONS (Adjustable, vent stack can be adjusted 1" to either side)

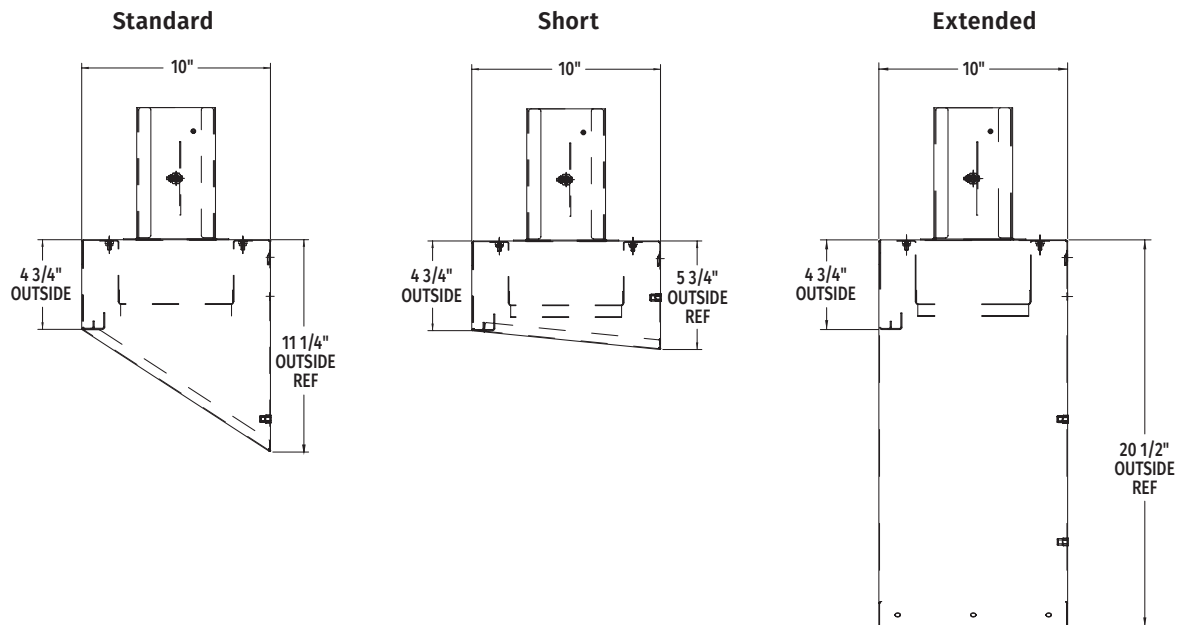

As continued product improvement is a policy of Hobart, specifications are subject to change without notice.