

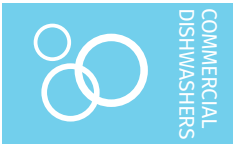

Project \_\_\_\_\_  
 AIA # \_\_\_\_\_ SIS # \_\_\_\_\_  
 Item # \_\_\_\_\_ Quantity \_\_\_\_\_ C.S.I. Section 114000

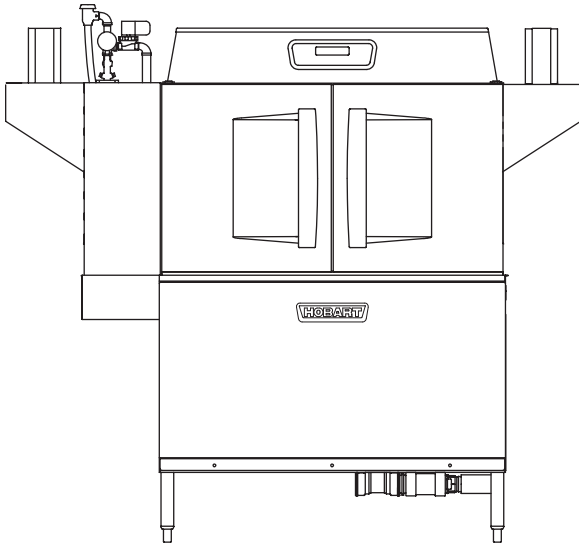

## CL54eN-EGR ELECTRIC High Temperature Rack Conveyor Dishwashing Machine



### SPECIFIER STATEMENT

Specified dishwasher will be Hobart CL54eN Energy Recovery electric tank heat model with drain water energy recovery (DWER) and Opti-Rinse™. Includes 245 racks per hour capacity, insulated ergonomic cabinet style doors, dirty water indicator, configurable “intelligent” de-lime notification, top mounted computer controls, and NSF approved pot and pan cycle mode. The wash tank utilizes durable precision pressure sensor monitors in lieu of conventional mechanical floats. The 19.5" standard chamber height will accommodate up to (6) standard sheet pans at a time on an open-end sheet pan rack.

### STANDARD FEATURES

- + 245 racks per hour
- + Drain water energy recovery (DWER)
- + Opti-Rinse™ system
- + Drain water tempering kit
- + Rapid return conveyor drive mechanism
- + Internal stainless steel pressure-less 30 KW booster heater
- + Large double door opening for ease of cleaning
- + Doors are insulated & hinged with door interlock switches
- + 19.5" chamber height opening (accepts sheet pans)
- + Top mounted micro-processor control module
- + Energy saver mode (programmable auto-shut down)
- + Dirty water indicator
- + Manager activated low temperature alert
- + NSF rated configurable pot and pan dwell mode
- + Configurable “intelligent” delime alert notification
- + Service diagnostics
- + Self-aligning wash manifolds
- + Stainless steel anti-clogging wash arms
- + Removable pump intake screen
- + Stainless steel self-draining pump and impeller
- + Single, sloping scrap screen and deep scrap basket
- + Stainless panels enclose perimeter and bottom
- + Door actuated drain closure
- + Vent fan control
- + Booster heater control
- + ENERGY STAR® Certified

### OPTIONS & ACCESSORIES (Available at extra cost)

- Standard, short, and extended stainless steel vent hoods
- Direct drive unloader – adds 38" length. Reference spec F39520 for more details
- Side loader – SL23 adds 23" length, SL30 adds 30" length. Reference specs F40926 and F40927 for more details
- Blower-dryer – adds 33¼" to length. Reference spec F40252 for more details (ships separate from dishmachine, contact Hobart Service for installation)
- Flanged feet kit (requires two kits)
- Higher than standard chamber (24" opening)
- Table limit switch with 10' wire
- Correctional package (contact Hobart for details)
- Pressure regulator valve (PRV), for use with external booster
- Water shock absorber kit
- Factory-mounted circuit breakers (contact Hobart for details)
- Common electrical connection (see page 4)

CLEAN SERIES – CL54eN-EGR ELECTRIC

Approved by \_\_\_\_\_ Date \_\_\_\_\_ Approved by \_\_\_\_\_ Date \_\_\_\_\_



# CL54eN-EGR ELECTRIC

## High Temperature Rack Conveyor

### Dishwashing Machine

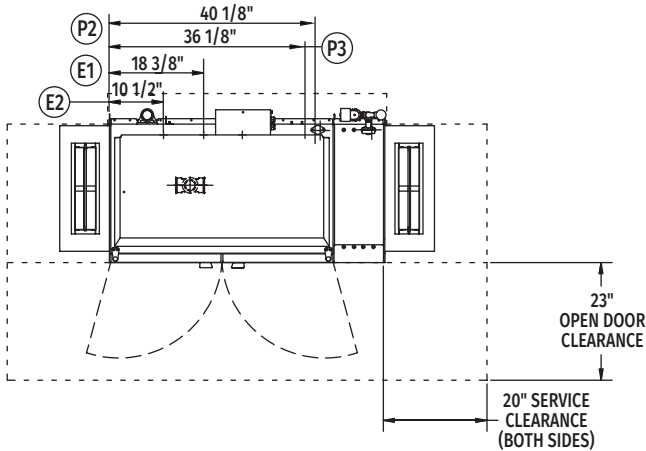

Top View Left to Right

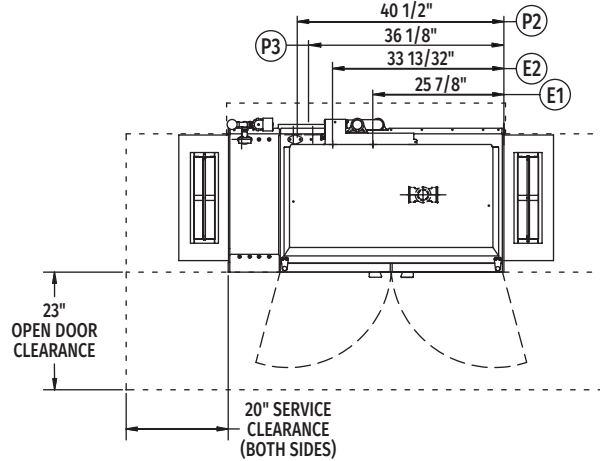

Top View Right to Left

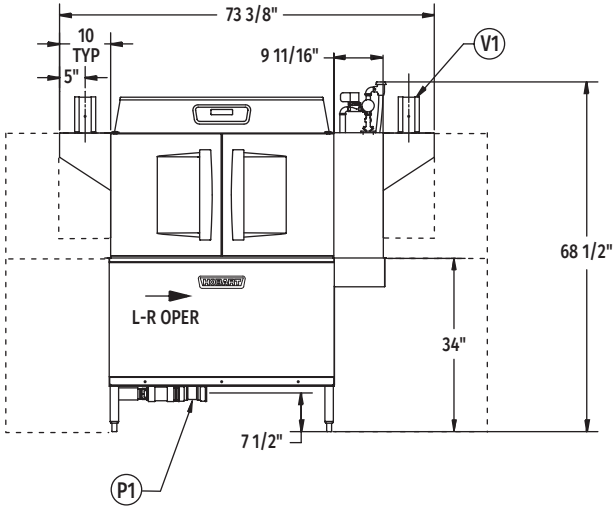

Front View Left to Right

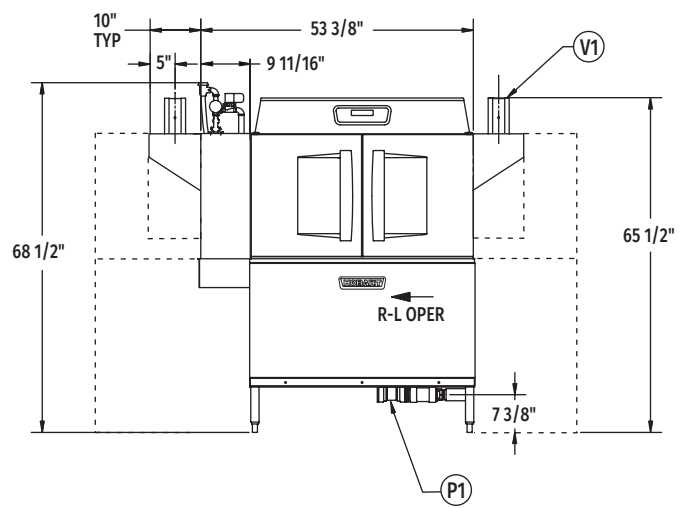

Front View Right to Left

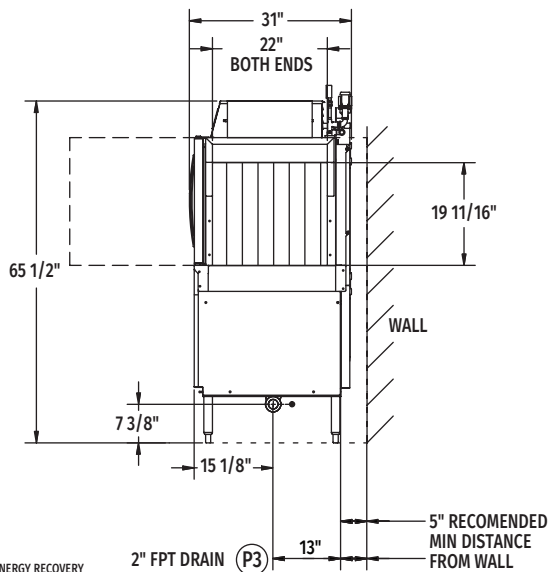

Side View

#### Tabling Connection: 54" inside tank (at table connection)

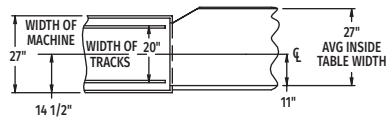

#### Suggested Track and Table Layout

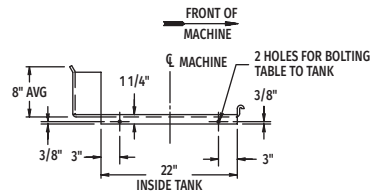

#### View Showing Hole Locations in Turned Down Portion of Table

MODEL- CL54eN ENERGY RECOVERY  
L-R OPERATION  
D-974803  
REV B

MODEL- CL54eN ENERGY RECOVERY  
R-L OPERATION  
D-974802  
REV B



# CL54eN-EGR ELECTRIC

## High Temperature Rack Conveyor Dishwashing Machine

### LEGEND

Electrical Connections	
<b>E1</b>	Motors, controls, and electric tank heat 1-1/4" or 2" conduit, 63-3/4" AFF.
<b>E2</b>	Internal electric booster 1-1/4" or 2" conduit, 63-3/4" AFF.
<b>NOTE:</b> Common electrical connection (single point) available, see page 4 for details.	
Plumbing Connections	
<b>P1</b>	Drain. May be drained to either side of valve, plug opposite side 2" FPT. Recommend a floor drain minimum of 12" from machine for access and maintenance. 7-3/8" AFF.
<b>P2</b>	Hot water. 1/2" FPT connection. 1/2", 11-3/16" AFF. See plumbing notes for required temperatures.
<b>P3</b>	Cold water connection 1/2" FPT, cold water temperature 80°F, maximum 7-3/8" AFF.
Vent Connections	
<b>V1</b>	Optional vent hoods, 4" x 16" vent stack with damper.

### SPECIFICATIONS

#### Capacities

Racks per Hour (NSF rated) . . . . .	245
Wash Tank (U.S. gallons). . . . .	23
Conveyor Speed (feet per minute). . . . .	6.8

#### Motor Horsepower

Drive . . . . .	1/6
Wash . . . . .	.2

#### Water Consumption

U.S. Gallons per Hour (maximum use at 20 PSI). . . . .	138
U.S. Gallons per Rack . . . . .	0.56
Peak Drain Flow (U.S. gallons per minute). . . . .	38

#### Heating

Tank Heat, Electric (kW) . . . . .	15
Electric Booster (built-in) (kW for 70°F rise) . . . . .	30

#### Venting

Load End (minimum CFM) . . . . .	200
Unload End (minimum CFM) . . . . .	400

**Shipping Weight (approximate)** . . . . .654 lbs.

**Crated Dimensions.** . . . . .63"L x 38"W x 78"H

<b>E1</b>	Electrical Connection (3 PH only) Motors, Controls and Electric Tank Heat		
Voltage	Rated Amps	Minimum Supply Circuit Ampacity	Maximum Protective Device
208/60/3	55.0	70	70
240/60/3	52.6	70	70
480/60/3	27.9	40	40
600/60/3	20.3	25	25
<b>NOTE:</b> Electric tank heat can be split from motors & controls, see page 4 for details.			

Dishmachine not provided with internal GFCI protection.

**NOTE:** Additional CLeN Voltages and Amperages are available, see document F40972.

<b>E2</b>	Booster Heat 30 kW Minimum 110°F Incoming Water		
Voltage	Rated Amps	Minimum Supply Circuit Ampacity	Maximum Protective Device
208/60/3	83.9	90	90
240/60/3	80.2	90	90
480/60/3	40.1	50	50
600/60/3	26.9	40	40

CL54eN-EGR Electric Heat Dissipation	
BTU/HR.	
Latent	Sensible
42,000	18,000

**WARNING: Plumbing and electrical connections should be made by qualified personnel who will observe all the applicable plumbing, sanitary, safety codes and National Electrical Code.**

**Plumbing Notes:** Minimum incoming water temperatures: 110°F for 30kW internal booster. Building flowing water pressure to dish machine is 20 PSI (+/- 5 PSI).

Single cold water connection supplies both drain water energy recovery and drain water tempering.

Recommended water hardness to be 3 grains or less for best results.



# CL54eN-EGR ELECTRIC

## High Temperature Rack Conveyor Dishwashing Machine

### COMMON ELECTRICAL CONNECTION (SINGLE POINT) – CONTACT FACTORY FOR ADDITIONAL INFORMATION

Common Electrical Connection (Includes Motors & Controls, Electric Tank Heat, & Electric Booster Heater)			
Voltage	MACHINE AND 30kW BOOSTER		
	Rated Amps	Minimum Supply Circuit Ampacity	Maximum Protective Device
208/60/3	139	175	175
240/60/3	133	150	150
480/60/3	68	90	90
600/60/3	47.2	65	65

### FIELD CONVERTIBLE SERVICE CONNECTIONS

At time of installation, service connections for motors, controls, and electric tank heat can be split as necessary for installation.

Separate Service Connection for Electric Heat			
Voltage	Rated Amps	Minimum Supply Circuit Ampacity	Maximum Protective Device
208/60/3	45.0	60	60
240/60/3	43.0	60	60
480/60/3	22.0	30	30
600/60/3	14.4	20	20

Separate Service Connection for Motors & Controls			
Voltage	Rated Amps	Minimum Supply Circuit Ampacity	Maximum Protective Device
208/60/3	10.0	15	15
240/60/3	9.7	15	15
480/60/3	6.4	15	15
600/60/3	5.8	15	15

**NOTE:** Additional CLeN Voltages and Amperages are available, see document F40972.

### VENT HOOD OPTIONS (Adjustable, vent stack can be adjusted 1" to either side)

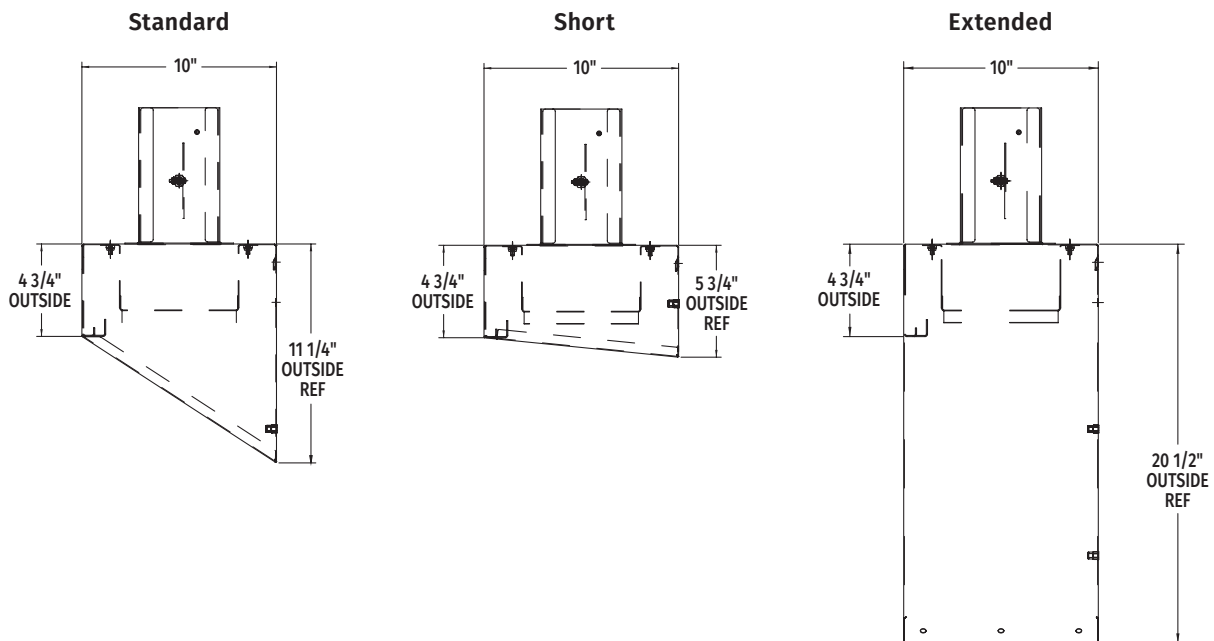

As continued product improvement is a policy of Hobart, specifications are subject to change without notice.