



Project _____

Item # _____

Quantity _____

Flav-R-Savor® Large Capacity Display Cabinets

Models: WFST-1X, -2X,
LFST-48-1X, -2X

Hatco's Large Capacity Display Cabinets help you hold more food, while still maintaining proper serving temperatures. The left and right side heat sources create a "blanket" effect around the food. The air flow rate enables the cabinets to rapidly recover to preset temperature after opening and closing the door. Single-door or two-door options give you ease of self-serve applications or pass-thru convenience.

WFST (humidified). Prepare food in advance of peak periods and place product straight from the oven into the full-view cabinets to increase impulse sales. The use of controlled, moisturized heat maintains serving temperature and texture longer than conventional holding equipment.

LFST (non-humidified) models are perfect for holding wrapped or boxed products side-by-side, increasing visibility and easy access.

Standard features

- Hold standard sheet pans 18" x 26" (457 x 660 mm)
- Tempered glass doors and side panels provide maximum heat retention and allow for full cabinet display
- Shatter-resistant incandescent lights (LFST) or LED lighting (WFST), enhance product displays
- Standard multi-purpose rack with shelves adjustable in 2" (51 mm) increments to fit multiple foodservice uses with slant or horizontal shelves

WATER QUALITY REQUIREMENTS

Water supply in excess of 3.0 grains of hardness per gallon (GPG) (.75 grains of hardness per liter) must be treated and softened before being used. Water containing over 3.0 GPG (.75 GPL) will decrease the efficiency and reduce the operating life of the unit.

Note: Product failure caused by liming or sediment buildup is not covered under warranty.



IFS anti-microbial coatings use naturally-occurring, environmentally sustainable, silver ions to help inhibit the growth of microbes on the powder coated surface. See www.hatcocorp.com/antimicrobial-paint for more information.



For operation, location and safety information, please refer to the Installation and Operating Manual.



WFST-1X in standard Unfinished Metal (signs not included)



LFST-2X in Designer Black

Options (available at time of purchase only)

Designer Colors – Non-standard colors are non-returnable

- Unfinished Metal standard on WFST
- Black standard on LFST
- Clear Anodized Aluminum (LFST only)
- Warm Red Black Gray Granite White Granite
- Navy Blue Hunter Green Antique Copper
- Self-Closing Sliding Doors (WFST-2X only, in lieu of Hinged Doors on one side only)
- Self-Closing French Doors (WFST models only)
- Neutral White (cool) LED lighting (in lieu of standard Warm White) (WFST models only)
- 60 Watt Halogen Bulb in lieu of Standard Display Light (LFST models only)
- Temperature Control Timer - 6 channel control touchscreen display (WFST models only)

Accessories

- 4" (102 mm) Adjustable Legs (WFST models only)

HATCO CORPORATION | P.O. Box 340500 Milwaukee, WI 53234-0500 U.S.A. | (800) 558-0607 | (414) 671-6350



www.hatcocorp.com | support@hatcocorp.com | [Find a Hatco Rep](#) | [Image Library](#) | [Document Library](#) | [Patents](#) | [Chat](#)





Flav-R-Savor® Large Capacity Display Cabinets

Models: WFST-1X, -2X, LFST-48-1X, -2X

WFST MODELS

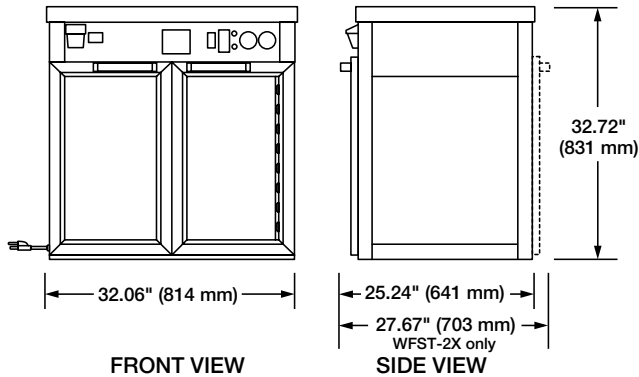

LFST MODELS

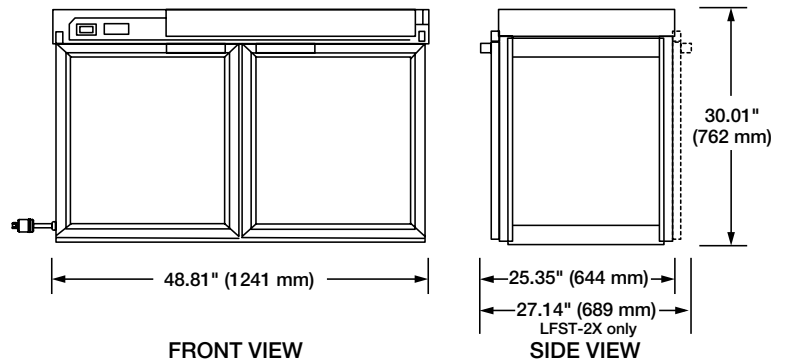

SPECIFICATIONS Large Capacity Holding Cabinets - Humidified

The shaded areas contain electrical information for international models

Model	Description	Dimensions (W x D x H)	Cabinet Opening (W x H)	Volts	Hz	Watts	Amps	Plug	Ship Weight*
WFST-1X	2 Doors with 4-shelf rack	32.06" x 25.24" x 32.72" (814 x 641 x 831 mm)	28" x 21.94" (711 x 557 mm)	120	60	1715	14.3	NEMA 5-15P [▲]	182 lbs. (83 kg)
				120/208-240	60	2315	14.3	NEMA L14-20P	
				220	50/60	1706	7.7	CEE 7/7 Schuko	
				240	50/60	1712	7.1	BS-1363	
WFST-2X	4 Doors with 4-shelf rack	32.06" x 27.67" x 32.72" (814 x 703 x 831 mm)	28" x 21.94" (711 x 557 mm)	120	60	1715	14.3	NEMA 5-15P [▲]	188 lbs. (85 kg)
				120/208-240	60	2315	14.3	NEMA L14-20P	
				220	50/60	1706	7.7	CEE 7/7 Schuko	
				240	50/60	1712	7.1	BS-1363	

Large Capacity Holding Cabinets - Non-Humidified

Model	Bulbs	Description	Dimensions (W x D x H)	Cabinet Opening (W x H)	Volts	Hz	Watts	Amps	Plug	Ship Weight*
LFST-48-1X	6	2 Doors with 3-shelf rack	48.81" x 25.35" x 30.01" (1240 x 644 x 762 mm)	44" x 22" (1118 x 559 mm)	120/208-240	60	2150	14.6	NEMA L14-20P	222 lbs. (101 kg)
LFST-48-2X	6	4 Doors with 3-shelf rack	48.81" x 27.14" x 30.01" (1240 x 689 x 762 mm)	44" x 22" (1118 x 559 mm)	120/208-240	60	2150	14.6	NEMA L14-20P	230 lbs. (104 kg)

* Shipping weight includes packaging.

▲ Canada, use NEMA 5-20P.

WATER TANK CAPACITY

WFST models: ¾ gallon (2.8 liters).

CORD LOCATION

Facing controls, left-hand side panel, lower right corner.

PLUG CONFIGURATIONS

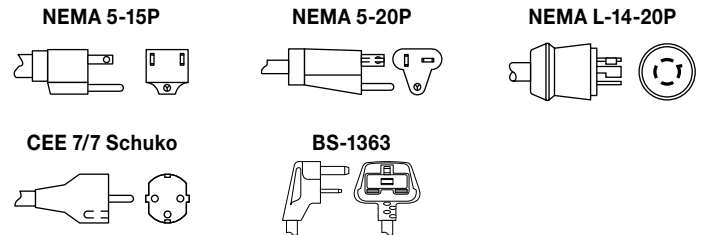

PRODUCT SPECS

Large Capacity Display Cabinets

The Large Capacity Display Cabinet shall be a Flav-R-Savor® Model ..., rated at ... volts and ... watts, as manufactured by the Hatco Corporation, Milwaukee, WI 53234 U.S.A.

The WFST cabinet shall have ... door(s), tempered glass sides, adjustable rack, stacking hardware, and LED display lights. It shall include a water reservoir, humidity selector switch, temperature selector dial, On/Off switch, indicating lights, and a 6' (1829 mm) cord with plug attached.

Accessories shall include adjustable legs and pans.

The LFST cabinet shall have ... self closing French-style glass doors, incandescent display lights, tempered glass sides, sign holders on all four sides, and removable adjustable rack. It shall include a temperature selector dial, On/Off switch, indicating lights, and a 6' (1829 mm) cord with plug attached.

Accessories shall include pans.

Warranty consists of 24/7 parts and service assistance (US and Canada only).

HATCO CORPORATION | P.O. Box 340500 Milwaukee, WI 53234-0500 U.S.A. | (800) 558-0607 | (414) 671-6350



www.hatcocorp.com | support@hatcocorp.com | [Find a Hatco Rep](#) | [Image Library](#) | [Document Library](#) | [Patents](#) | [Chat](#)