



Project _____

Item # _____

Quantity _____

Toast King® Electric Conveyor Toasters

Models: TK-72, -75, -100, -105, -135B, -155B

The Hatco Toast King Conveyorized Toaster combines fast heat-up, uniform toasting and dependable performance to handle peak serving periods.

Standard features

- Utilizes conveyor speed, not temperature to determine toasting color
- Toasts buns up to 5.5" (140 mm) wide and "Texas Toast" up to 1.25" (32 mm) thick
- Stainless steel construction for years of trouble-free service.
- Power saving thermostat for energy savings during non-peak serving times
- Toast storage area keeps bread warm and dry
- Tray extends 3.5" (89 mm)
- Unit comes with 4' (1219 mm) attached cord and plug
- Metal sheathed heating elements guaranteed against burnout and breakage for two years

Capacities below are on highest setting

Model	Bread or bun slices per minute	Bread or bun slices per hour	Basket capacity
TK-72	12	720	2 slices wide
TK-75	12	720	2 slices wide
TK-100	16	1000	3 slices wide
TK-105	16	1000	3 slices wide
TK-135B	22	1350	3 slices wide
TK-155B*	25	1550	3 slices wide

- TK-155B toasts 3-part hamburger buns. the outside buns are toasted on one side, the middle bun is toasted on both sides.



Options (available at time of purchase only)

- Control Cover, Bracket, Mounting Hardware, and Fuse Cover

Accessories

- 4" (102 mm) Adjustable Legs (4)



For operation, location and safety information, please refer to the Installation and Operating Manual.



HATCO CORPORATION | P.O. Box 340500 Milwaukee, WI 53234-0500 U.S.A. | (800) 558-0607 | (414) 671-6350



www.hatcocorp.com | support@hatcocorp.com | [Find a Hatco Rep](#) | [Image Library](#) | [Document Library](#) | [Patents](#) | [Chat](#)



Toast King® Electric Conveyor Toasters

Models: TK-72, -75, -100, -105, -135B, -155B

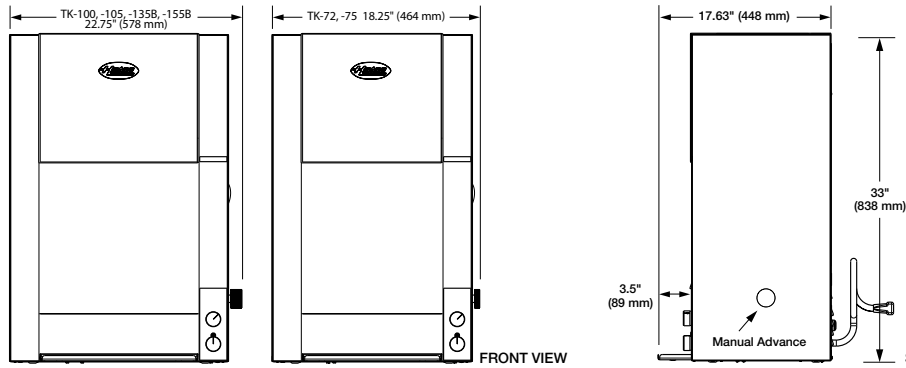

SPECIFICATIONS Toast King Electric Conveyor Toasters

The shaded areas contain electrical information for international models only

Model	Dimensions ¹ (Width x Depth x Height)	Volts	Hertz	Phase	Watts	Amps	Plug	Ship Weight*
TK-72	18.25" x 17.63" x 33.25" (464 x 448 x 845 mm) (Basket size: 10"W x 4.63"H (254 x 118 mm))	208	60	Single	4038	19.4	NEMA 6-20P*	73 lbs. (33 kg)
		240				16.8		
		200	50		3733	18.7	NEMA 6-20P*	
		220			60	4038	18.4	
		220-230 (CE)	50		4038-4414	18.4-19.2	No Cap	
		230-240 (CE)			3708-4038	16.1-16.8		
240	4038	16.8						
TK-75	18.25" x 17.63" x 33.25" (464 x 448 x 845 mm)	220-230 (CE)	50	Single	5238-5725	23.8-24.9	No Cap	73 lbs. (33 kg)
		230-240 (CE)			4811-5238	21.0-21.8		
TK-100	22.75" x 17.63" x 33.25" (578 x 448 x 845 mm) (Basket size: 14.5"W x 4.63"H (368 x 118 mm))	208	60	Single	5038	24.0	NEMA 6-30P	88 lbs. (40 kg)
		240				21.0		
		200	50		4657	23.3	NEMA 6-30P	
		220	60		5038	22.9	No cap	
		220-230 (CE)	50		5038-5507	22.9-23.9		
		230-240 (CE)			4626-5038	20.1-21.0		
240	5038	21.0						
TK-105	22.75" x 17.63" x 33.25" (578 x 448 x 845 mm)	220	50	Single	7438	33.8	No Cord	88 lbs. (40 kg)
		240			5678	23.7	No Cap	
		220-230 (CE)			7438-8129	33.8-35.3	No Cord	
		230-240 (CE)			6830-7438	30.0-31.0		
TK-135B	22.75" x 17.63" x 33.25" (578 x 448 x 845 mm) (Basket size: 14.5"W x 4.63"H (368 x 118mm))	208	60	Single	4338	20.9	NEMA 6-30P	88 lbs. (40 kg)
		240				18.1	NEMA 6-20P*	
		220	60		4338	19.7	No Cap	
		220-230 (CE)	50		4338-4741	19.7-20.6		
		230-240 (CE)			3984-4338	17.3-18.1		
		240			4338	18.1		
TK-155B	22.75" x 17.63" x 33.25" (578 x 448 x 845 mm) (Basket size: 14.5"W x 4.63"H (368 x 118mm))	208	60	Single	5018	24.1	NEMA 6-30P	88 lbs. (40 kg)
		240				20.9		
		220	60		5018	22.8	No Cap	
		240	50					

¹ Width included 3/4" for manual advance knob. Depth includes tray extension of 31/2". * Shipping weight includes packaging.

* NEMA 6-30P for Canada. NOTE: Units with "No Cap" plug configuration come with a power cord only (no plug).

CORD LOCATION

Lower right center of unit on back.

PLUG CONFIGURATIONS

NEMA 6-20P

NEMA 6-30P

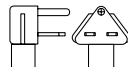
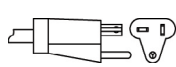

PRODUCT SPECS Conveyor Toasters

The Toast King® Electric Conveyor Toaster shall be a Hatco model ... as manufactured by the Hatco Corporation, Milwaukee, WI 53234 U.S.A. The toaster shall have the capacity to toast up to ... pieces per minute and it shall be rated at ... kW, ... volts, single phase. The toaster shall be of stainless steel design and shall include a front mounted control panel with a toast selector knob, variable speed control knob,

and an aluminum toast collector pan. The toaster will have multiple metal sheathed heating elements and an impedance protected motor. It shall be complete with factory attached UL listed 4' (1219 mm) cord and plug.

Warranty consists of 24/7 parts and service assistance (U.S. and Canada only).

HATCO CORPORATION | P.O. Box 340500 Milwaukee, WI 53234-0500 U.S.A. | (800) 558-0607 | (414) 671-6350



www.hatcocorp.com | support@hatcocorp.com | [Find a Hatco Rep](#) | [Image Library](#) | [Document Library](#) | [Patents](#) | [Chat](#)