

Project: _____	AIA# _____
Item #: _____ Qty: _____	SIS# _____
Model #: _____	

Wait Stations

WS24, WS36, WS36-S

Standard Features

- All stainless steel construction
- Integrated back and side splashes
- Radius work surface corners for easy cleaning
- Work surface features front marine edge
- Cabinet includes intermediate shelf and special compartment for vertical tray storage
- Vertical tray storage compartment specifically designed to hold 14" or 16" round server trays
- Recessed hole in tray storage compartment floor prevents round trays from rolling out
- Includes left side mounted menu holder
- WS36-S model includes welded bowl with removable plastic wash rag basin
- Optional wall mount pan holder (WPH) with 6" deep stainless steel pan for use as an ash tray dump or wash rag basin
- Includes wall mounting bracket



WS24



Intertek
 4004503
 Conforms to ANSI/NSF STD 2



WS36-S
 with optional WPH
 wall mount pan holder

To view cleaning and care instructions, please visit: http://www.glastender.com/PDF/F-423-011_ss_clean_care.pdf

Specifications	Mounting Details
-----------------------	-------------------------

Drain

- No plumbing required

Bowl Dimensions for model WS36-S

- 9-1/4" by 11-1/2" by 6" deep

Materials

- 20 gauge stainless steel parts include:
 All components unless otherwise noted
- 16 gauge stainless steel parts include:
 menu holder and optional wall mount pan holder



Detail showing optional WPH wall mount pan holder installed

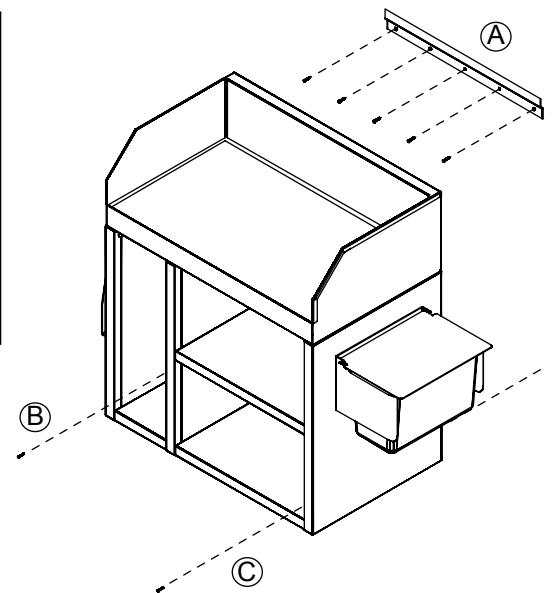

⚠ WARNING: The plastic wet waste strainer included with this product can expose you to chemicals including Bisphenol A (BPA), which is known to the State of California to cause birth defects or other reproductive harm. For more information, go to www.P65Warnings.ca.gov. **Warning applies to State of California only.** Part #03000483

Mounting bracket (A) attaches to the wall. The Wait Station is placed on the mounting bracket, then is secured to the wall with screws at (B) and (C).

Glastender, Inc. • 5400 N Michigan Rd • Saginaw, MI • 48604-9780 989.752.4275 • 800.748.0423 • Fax 989.752.4444 www.glastender.com	Approval/Notes:
Specifications subject to change without notice. For current specifications please visit our website.	

Wait Stations

Dimensional Information

WS24

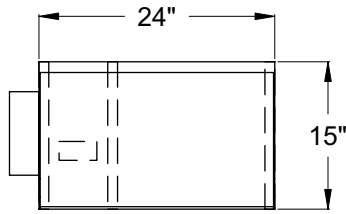

Plan View

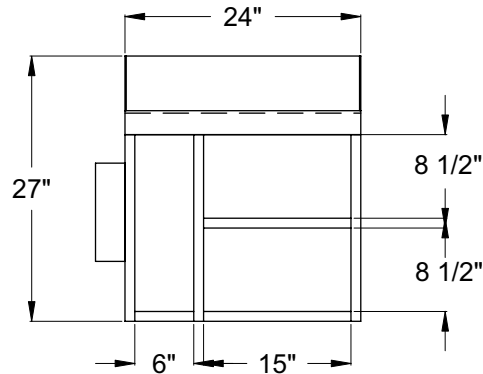

Front View

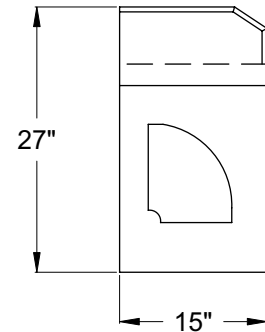

Side View

WS36

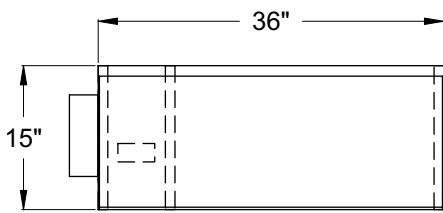

Plan View

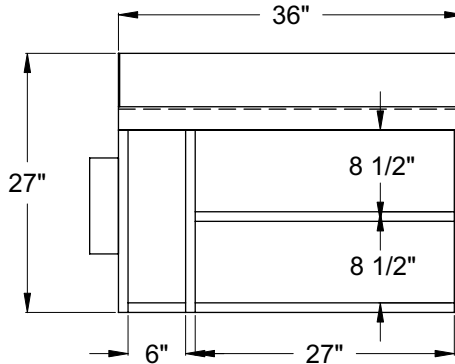

Front View

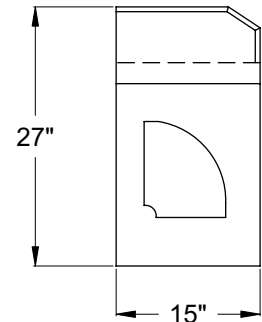

Side View

WS36-S

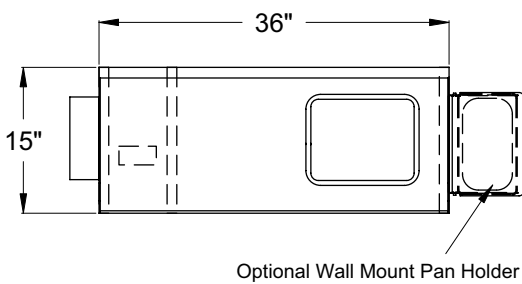

Plan View

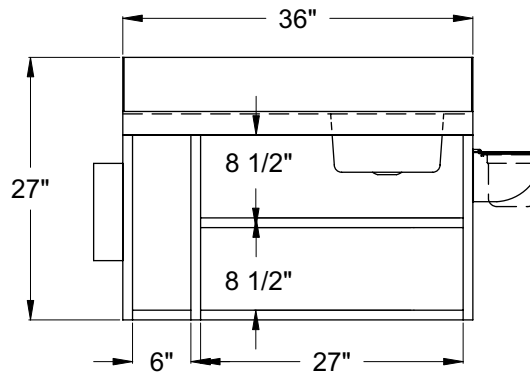

Front View

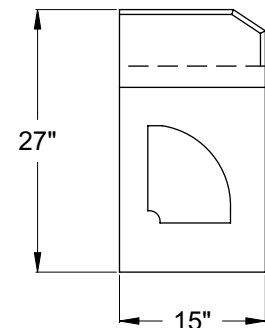

Side View