

Operation Manual

Glastender®

A Family Company Manufacturing In The USA Since 1969

GT-18 SERIES GLASSWASHERS

GT-18, GT-18+1, GT-18+1L, GT-18+1R, GT-18+2, GT-18+2-IC and GT-18+3
(manufactured after August 2006)

GT-18 Glasswasher Operation & Maintenance Video -

<https://glastender.com/pl/operation-manuals/gt-18>

The GT-18 is a simple and effective glasswasher that, if properly maintained, will provide years of reliable service. This video provides a visual illustration of proper care and cleaning of the glasswasher.



GT-18



GT-18+2

Glastender, Inc. · 5400 North Michigan Road · Saginaw, MI · 48604-9780
800.748.0423 · 989.752.4275 · Fax 989.752.4444 · <https://glastender.com>



Index

<u>Topic</u>	<u>Page</u>
Introduction.....	1
What is a glasswasher?	1
Utility Requirements and Connections	2
Main Section - Front View	2
Uncrating and Start-Up Instructions	3
Operation.....	4
Thermostat Control	4
Low Water Pressure.....	4
Exploded View of GT-18 Series Glasswashers	5
Wiring Diagrams	6-8
Useful Information About Water, Detergent and Sanitizer	9
Important Information about Chemicals	10
Tips for Trouble-Free Operation	11
Cleaning Instructions.....	12
Trouble Shooting Guide	13
Terms and Conditions.....	14
Warranty	15

Introduction

This manual describes the operational features of the GT-18, GT-18+1, GT-18+1L, GT-18+1R, GT-18+2, GT-18+2-IC and GT-18+3 model glasswashers. Please review this information before attempting installation and operation. Long term, trouble-free operation will follow if good housekeeping and maintenance procedures are followed.

For a video illustration of care and cleaning of the GT-18 visit <https://glastender.com/pl/operation-manuals/gt-18>.

Thank you for selecting Glastender, Inc. products.

What is a Glasswasher?

Glastender, Inc. has been manufacturing automatic glasswashers since 1969. Today, Glastender glasswashers have been installed around the world. But what is a glasswasher? It is simply a piece of machinery that washes glassware, which eliminates the need for human labor and the conventional three-compartment sink. The glasswasher is, in effect, a mechanized three-compartment sink. It “washes”, “rinses”, and “sanitizes” glassware.

Note the Simplicity:

<u>FUNCTION</u>	<u>DESIGN</u>
WASH	120°F (48.9°C) water and a preset portion of detergent join in the tank. During operation, 5 gallons per minute of hot soapy water are pumped in a forceful, but gentle, spray pattern across the moving glassware. When the wash cycle is complete, all water is drained. While the drain is still open, clean water pre-rinses the holding tank to prepare for the rinse and sanitize cycle.
RINSE AND SANITIZE	120°F (48.9°C) water and a preset portion of sanitizer and rinse aid join in the tank. During operation, 5 gallons per minute of rinse water are pumped in a forceful, but gentle, spray pattern across the moving glassware. At the end of the cycle, all water is drained so the next load can begin with fresh, clean water.

Please read on to learn more about this simple machine.

Utility Requirements and Connections

1. *General Plumbing*
 - a. 1/2" OD (or larger) copper to 3/8" FMPT adapter provided
 - b. Minimum water pressure is 25 PSI
 - c. Maximum water pressure is 100 PSI. Install water pressure regulator if line pressure is over 100 PSI. Water valve on unit has built-in strainer and flow control to provide consistent volume between 25 and 100 PSI
 - d. Install separate water shut-off valve
 - e. Unit has built-in air gap - vacuum breaker is not required
 - f. Maximum temperature is 150°F (66°C)
 - g. Minimum temperature is 120°F (49°C)
 - h. Consumption is 2-1/2 gallons per cycle
2. *Drain*
 - a. 1-1/2" tailpiece
 - b. Use open type floor drain for maximum drainage
3. *Electrical*
 - a. 120V, single phase, 60Hz, 6-foot grounded cord included
 - b. Dedicated 15 amp circuit recommended
 - c. Power requirements - 3.5 amps
4. *Detergent*
 - a. Extra heavy duty, non-foaming, commercial liquid dishwashing detergent is required - .30% concentration
 - b. Consult local chemical supplier to match detergent with local water conditions
5. *Sanitizer*
 - a. Liquid chlorine bleach (sodium hypochlorite - 5.25% solution) adjusted to 50 ppm
6. *Rinse Aid*
 - a. Liquid Rinse Aid adjusted for proper sheeting
7. *Installation Considerations*
 - a. 1" clearance required to remove top
 - b. Front side service is essential
 - c. Detergent, Sanitizer, and Rinse Aid containers are stored externally - six-foot lengths of tubing are provided. Storage for three one-gallon containers is required within five feet

Main Section Front View

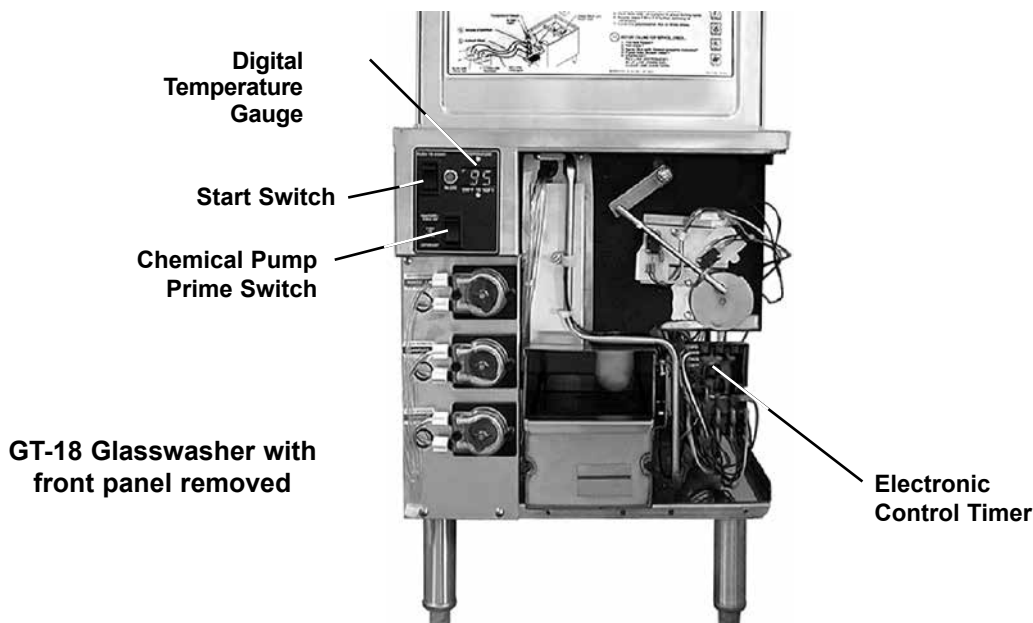

Uncrating and Start-Up Instructions

The glasswasher is shipped in two cartons. After uncrating, follow this procedure:

1. Set in place and install top.
2. Place chemical Feed Lines into the proper chemical containers.
 - a. Red is detergent.
 - b. Blue is rinse aid.
 - c. Clear is sanitizer.

WARNING: The chemicals used in commercial glasswashing are very harsh. Exposure to human skin can cause severe burns. Chemical containers should be stored in a manner and/or location that prevents them from spilling or splashing. Chemical containers must be secured. Please consult your chemical vendor to ensure proper storage or call the Glastender factory to purchase a clip-on chemical rail, part number 01000710.

3. After utility connections described above are completed, plug in glasswasher.
4. Depress Prime switches to fill Feed Lines. NOTE: Always cycle the machine after using the prime switches. Undiluted chemicals will damage stainless steel.
5. Cycle the glasswasher and check chemical settings.
6. If chemical adjustment is required, unplug glasswasher, remove front panel, and adjust chemicals as required using the Electronic Control Timer. See chemical adjustment procedure below.

Chemical Adjustment Procedure

The chemical strengths should be tested with a professional test kit by the chemical supplier. Water samples should be taken during the wash cycle and the rinse cycle.

- Detergent - .30% concentration
- Sanitizer - 50 PPM (sodium hypochlorite [bleach])
- Rinse Aid - until proper sheeting is achieved

Detergent: If the factory setting does not render the proper concentration, turn the detergent adjustment knob clockwise to increase or counterclockwise to decrease the dispense time. Repeat chemical testing procedure and adjust again if necessary.

Sanitizer: If the factory setting does not render the proper concentration, turn the sanitizer adjustment knob clockwise to increase or counterclockwise to decrease the dispense time. Repeat chemical testing procedure and adjust again if necessary.

Rinse Aid: If the factory setting does not render the proper level of sheeting, turn the rinse aid adjustment knob clockwise to increase or counterclockwise to decrease the dispense time. Run a test cycle to check wash results and adjust again if necessary.

7. Replace panel and plug in glasswasher. Cycle the glasswasher and check chemical settings. Repeat step 6 if necessary.

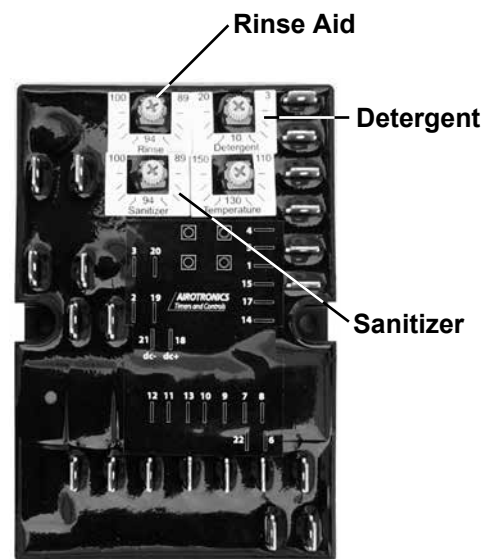

Electronic Control Timer

Operation

The GT-18 glasswasher has a two-minute cycle which consists of the following steps:

1. The drain will close, hot water fills the tank, and detergent dispenses.
2. At 15 seconds, the water recirculating pump starts.
3. At 20 seconds, hot water and detergent stop. NOTE: The detergent is adjustable so this timing may vary.
4. At 72 seconds, the water recirculating pump stops and the drain opens.
5. At 80 seconds, hot water flushes the tank.
6. At 85 seconds, the drain closes, hot water fills the tank, and sanitizer and rinse aid dispense.
7. At 98 seconds, the water recirculating pump starts.
8. At 105 seconds, hot water stops and sanitizer and rinse aid stop depending on the adjustment.
NOTE: The sanitizer and rinse aid are adjustable so this timing may vary.
9. At 115 seconds the water recirculating pump stops and the drain opens. The cycle is complete.

Thermostat Control

The Thermostat Control is pre-set by the factory to start the wash cycle when the water temperature reaches 130°F. When the Start Switch is actuated the Thermostat Control will flush water through the glasswasher for two minutes or until 130°F is reached. If 130°F temperature is not reached within two minutes, the machine will automatically begin the cycle. If the glasswasher starts at the factory setting, no further adjustment is required.

If the machine is regularly experiencing a delay in the cycle start due to low incoming water temperature, the thermostat control can be adjusted down to as low as 120°F to help decrease the delay. Please note the factory recommends a minimum incoming water temperature of 130°F for best wash results.

*NOTES:

1. A minimum incoming water temperature of 120°F is required to achieve proper wash results.
2. The Digital Temperature Gauge reads approximately ten degrees below actual incoming water temperature. (The temperature gauge will be accurate when the water tank is full.)
3. Place a thermometer in the water stream at the water inlet to determine the incoming water temperature.

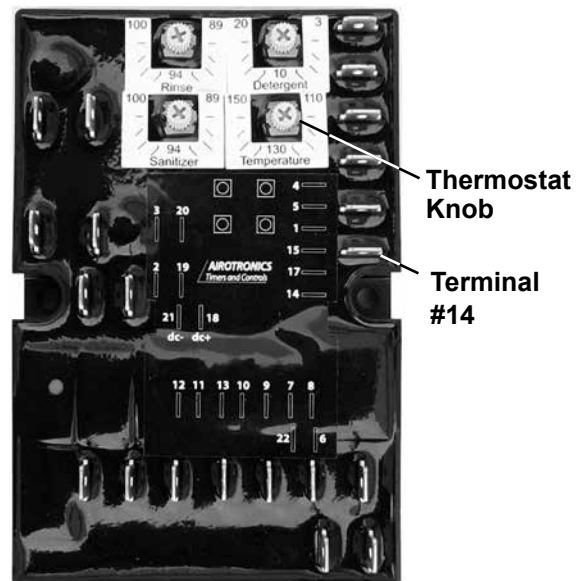

Do You Have Low Water Pressure?

Installations that have abnormally low water pressure may have trouble getting enough water into the glasswasher. Disconnect from the power source. Remove the red wire with white tracer at Terminal #14 on the master circuit board. Reconnect to the power source, resetting the circuit board. The overall cycle time will increase from 2 minutes to 2 minutes and 20 seconds. The additional 20 seconds will provide extra time to fill the tank during each of the wash and rinse cycles.

Exploded View of GT-18 Series Glasswashers

GT-18+3 GLASSWASHER

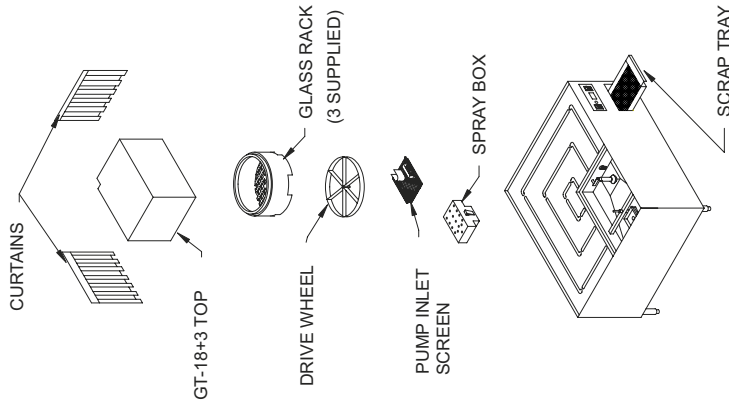

GT-18 SERIES GLASSWASHER
EXPLODED VIEW

GT-18+2 GLASSWASHER

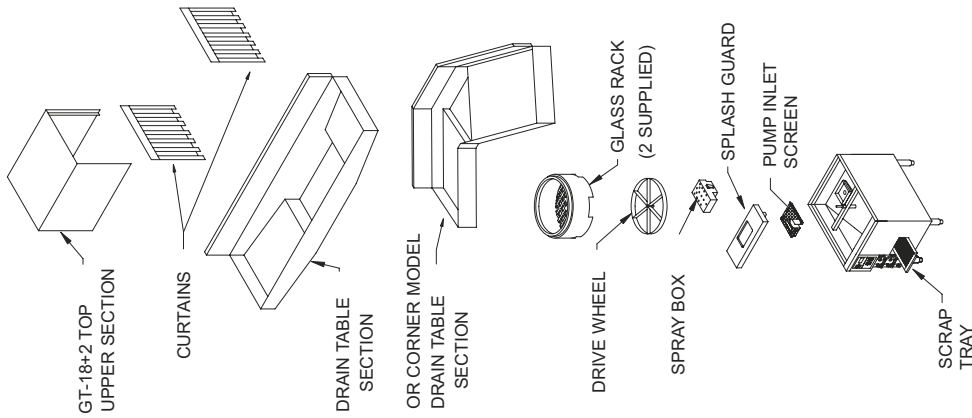

NOTE: EXTENDED DRAIN
TABLE MODELS

SIZE	GLASS RACKS
78"	3
90"	4
108"	5
120"	6

GT-18+1 GLASSWASHER

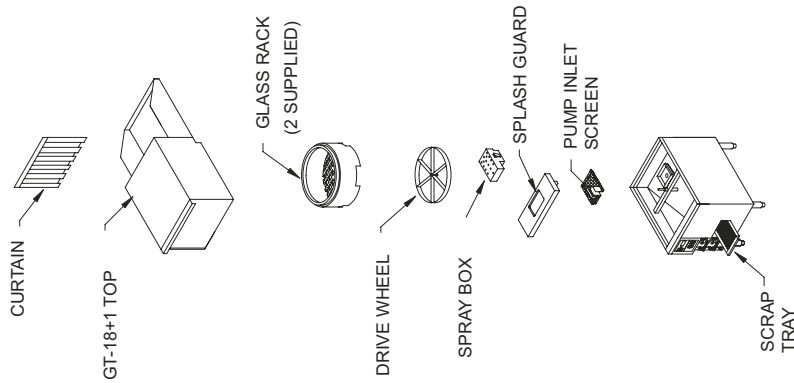

GT-18 GLASSWASHER

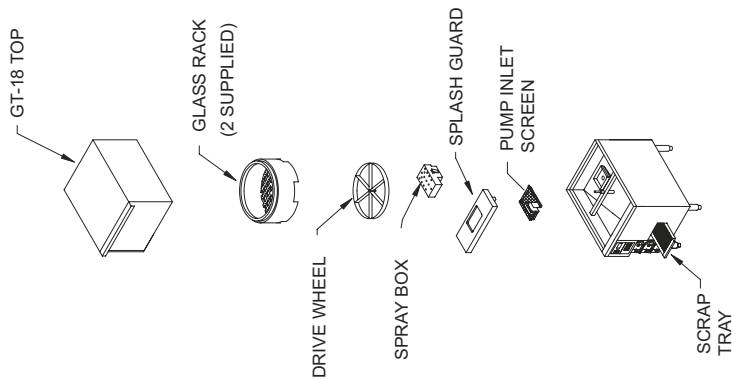

GT-18 Wiring Diagram

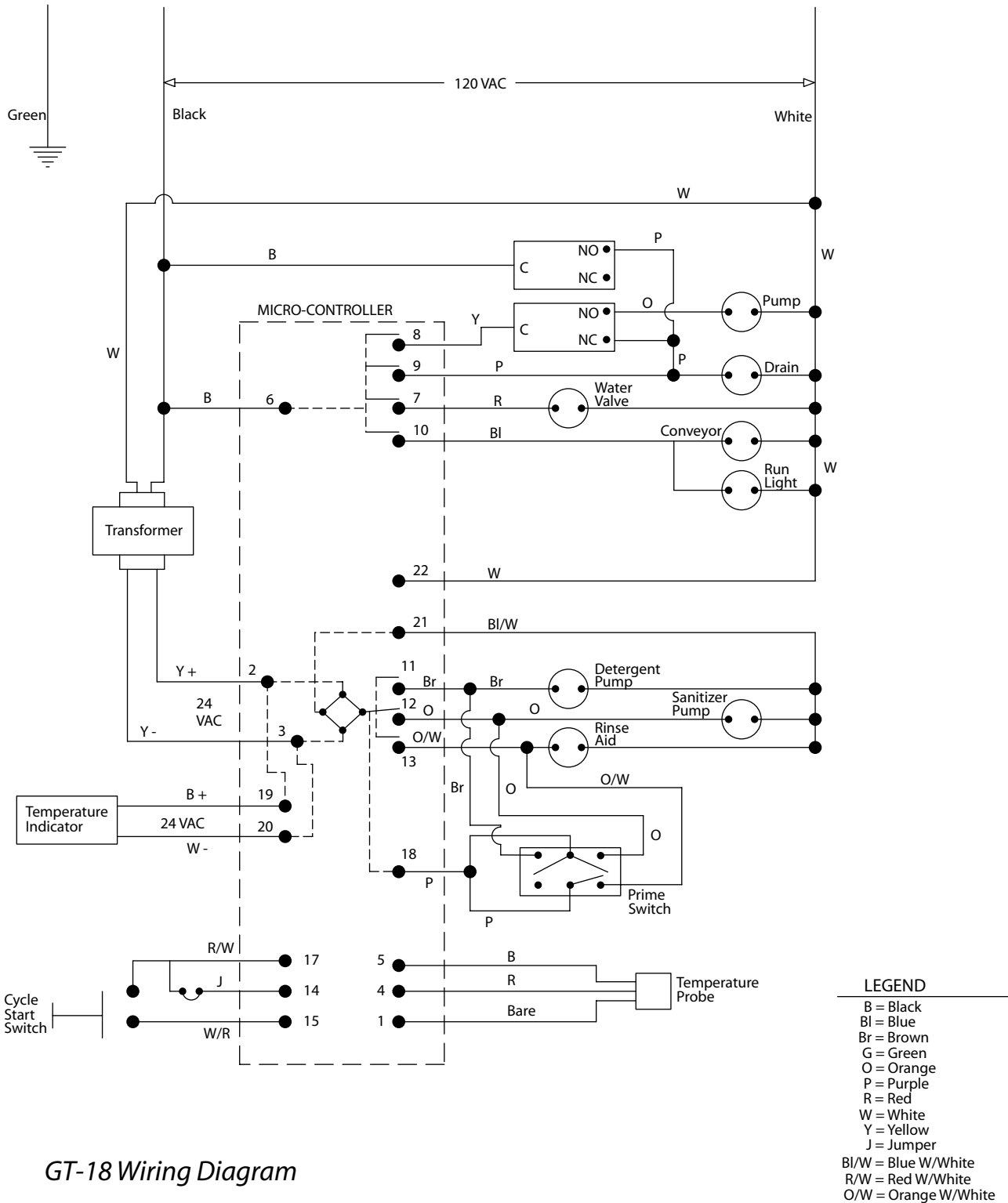

GT-18 Wiring Diagram

GT-18+3 Wiring Diagram

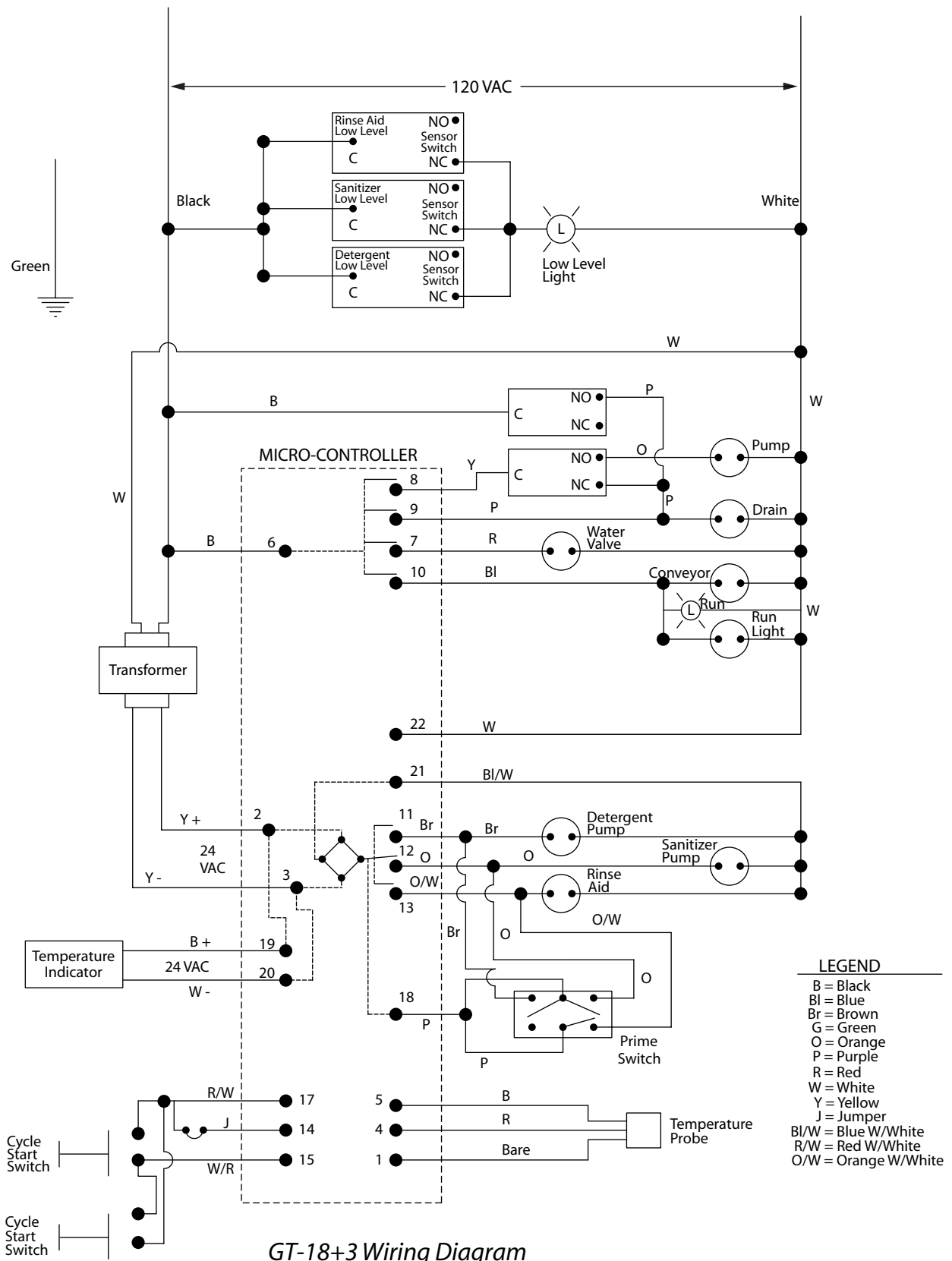

GT-18+3 Wiring Diagram

GT-18 with Export Transformer Wiring Diagram

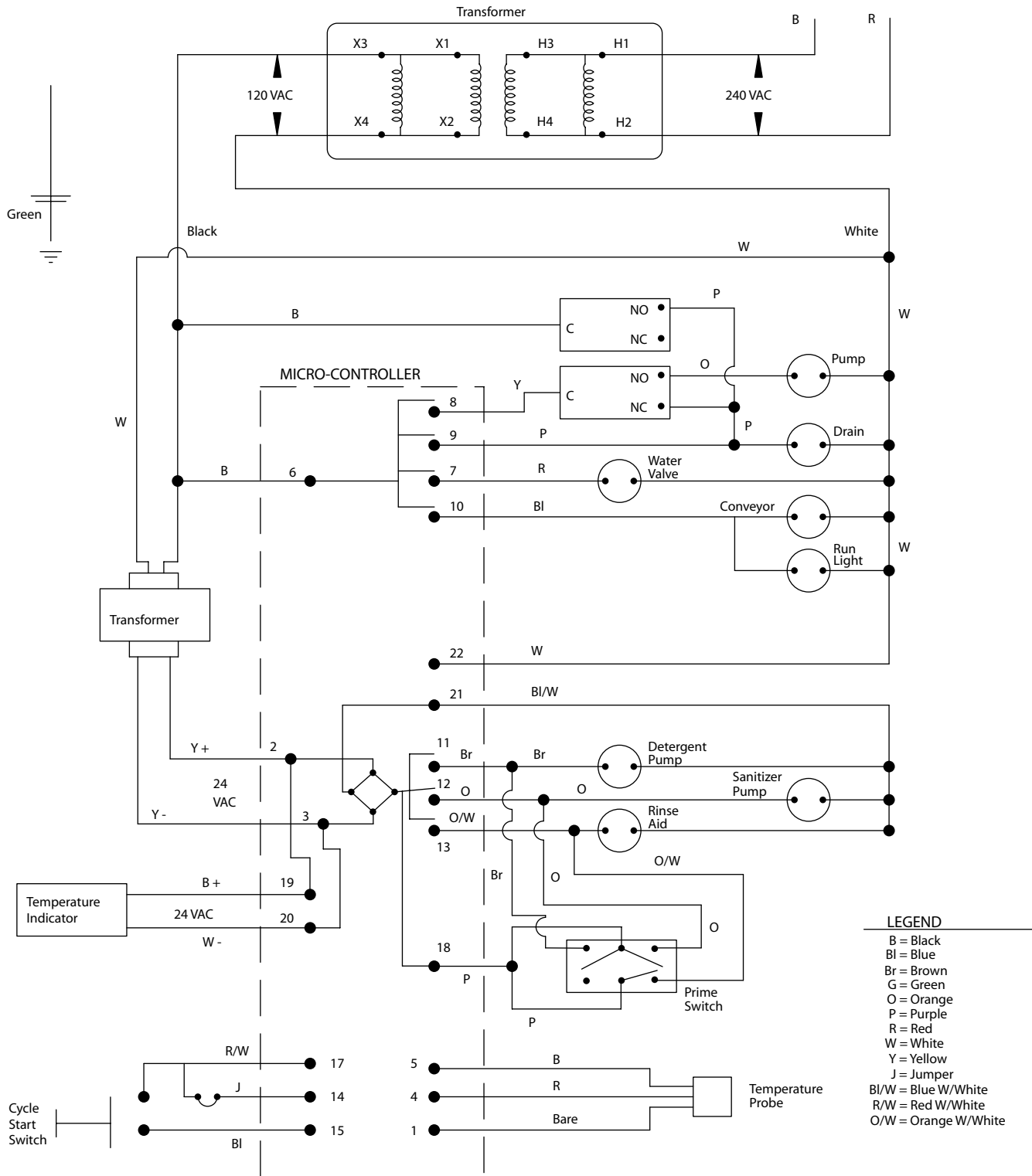

GT-18 with Export Transformer Wiring Diagram

Useful Information About Water, Detergent, and Sanitizer

Water Conditions

Your water supply fits one of the following descriptions.
Greater detergent consumption is required with “hard” water.

<u>DESCRIPTION</u>	<u>GRAINS PER GALLON</u>	<u>PARTS PER MILLION</u>
Soft	Less than 1.0	Less than 17.1
Slightly Hard	1.0 to 3.5	17.1 to 60
Moderately Hard	3.5 to 7.0	60 to 120
Hard	7.0 to 10.5	120 to 180
Very Hard	10.5 and over	180 and over

Detergent Titrating Instructions

An Alkalinity Test Kit, as recommended by your chemical supplier, is required for proper chemical adjustment. Follow kit instructions to test.

Sanitizer Titrating Instructions

Operate glasswasher to allow sanitizer levels to stabilize. With Conveyor removed and Conveyor Switch “On”, dip Chlorine test strip into Rinse Tank near Rinse Spray Box for one (1) second. Then immediately compare the strip to the scale on the side of the test strip container tube. Adjust sanitizer (bleach) to 50 PPM.

IMPORTANT NOTE: Glasswashers are **NOT** water conditioners. Consult local water conditioning experts to determine your specific water condition.

Important Information About Chemicals

The GT-18 glasswasher has chemical pumps that automatically dispense chemicals into the machine. The detergent and sanitizer chemicals are supplied by a chemical vendor. Since the type of chemicals and the condition of water varies by region, the chemical pumps are not pre-set at the factory. *The chemical pumps must be adjusted at start-up to achieve the proper titration levels or the machine may not produce good wash results.* Typically, the chemical vendor is responsible for adjusting the chemical pumps.

Since detergent and sanitizer chemicals play an important role in the performance of a glasswasher, understanding how the chemical pumps work and how to maintain them is very important. Reviewing the following information will help ensure the proper operation of your glasswasher and its chemical pumps:

1. CAUTION: Always cycle the machine after using the prime switches to rinse out the wash/rinse tank. Undiluted chemicals will damage stainless steel.
2. The chemical feed lines must be properly placed inside the appropriate chemical container. Damaged chemical lines will spill chemicals on the machine and floor and create poor wash results.
3. Every glasswasher requires chemical pump adjustment and titrating by a chemical vendor. Poor wash results will occur if the chemicals are not in proper concentration (see the operation manual for proper concentration levels).
4. Glasswasher chemicals are highly caustic and will cause severe burns when they contact human skin. These same caustic chemicals will also corrode stainless steel and destroy machine components. A glasswasher should be checked regularly for chemical leaks and any leaks should be corrected immediately.
5. All of the chemical tubing on a glasswasher should be inspected regularly and replaced at least once per year. The highly caustic chemicals cause the chemical tubing to get brittle, and since leaking chemicals destroy glasswasher components, it is good preventative maintenance to replace chemical tubing often. The various tubing includes the lower tubing assembly or main chemical feed line, the pump squeeze tube (especially susceptible to damage), and the upper tubing assembly from the pump to the glasswasher tank.
6. Chemical vendors that deliver chemicals to your establishment are typically responsible for adjusting the chemical levels in your glasswasher. They are also helpful for assisting you with chemical tubing inspection and replacement. Nothing removes your responsibility for proper maintenance, but the chemical vendor will help.

Tips for Trouble-Free Operation

1. **NEVER, NEVER** wash ash trays in the glasswasher. Since ashes are smaller than the opening in the Pump Inlet Screens, ashes, could adhere to glasses. Also, with ashes recirculating in the wash water, the cleaning effectiveness of the detergent is greatly reduced. The final result of washing ash trays is dirty glasses.
2. For best results, run glasswasher full of glassware. This keeps the water and detergent consumption to a minimum.
3. Water spotting can occur when glassware is placed on flat surfaces after washing thus preventing air to assist the drying process. Make sure the proper shelf liner or drying surface is used.
4. The maximum glass height is ten (10) inches to fit through the Top Section of the glasswasher. Keep this in mind when ordering beer pitchers and wine carafes.
5. Glasses which have been frequently washed by hand may have deposits of invisible “film.” Although initially appearing clean, these glasses may show unsightly signs of “dirt” after passing through the glasswasher. This unsightly condition will exist until the film is removed with frequent passes through the glasswasher, or it may be necessary to use a de-liming agent to clean glassware.
6. Do not place wet glasses into glass chillers or frosters. Allow glasses to dry and sanitizer odors to dissipate first.
7. Changing detergents may require readjustment of the Detergent Pump to maintain .30% detergent concentration. A greater volume of low strength detergent is required to maintain the proper level.
8. Only Glastender, Inc. replacement parts should be used. Components from other suppliers may result in machine malfunctions.

Please consult your Glastender, Inc. service agent if service or technical assistance is required. The factory is also available to answer any operational questions.

Cleaning Instructions

Regular maintenance of your Glastender glasswasher will extend its useful life and lower the service costs. The top section of a GT-18 glasswasher is removable to ease regular maintenance. Also, the following parts are removable for daily cleaning:

1. Spray Box
2. Splash Guard
3. Pump Inlet Screen
4. Drain Stopper (Overflow hole to rear)
5. Scrap Tray

The daily cleaning procedure consists of the following steps:

1. With machine not operating, remove Spray Box, Spray Box Gasket and Pump Inlet Screen.
2. Remove all debris.
3. Wipe the interior of tank with a damp cloth. For more stubborn soil or stains, you may scrub the interior of the tank with a Scotch-Brite® pad. Do **NOT** use steel wool.
4. Rinse the interior with clean water.
5. Rinse and scrub clean the Spray Box, Spray Box Gasket, and Pump Inlet Screen as necessary and reinstall into machine.
6. Check Detergent, Sanitizer, and Rinse Aid Containers. Refill or replace if empty.
7. Visually inspect the Detergent Inlet after the drain has closed and water begins to fill the tank. You should notice detergent intermittently dripping. Approximately 85 seconds later, visually inspect the Sanitizer and Rinse Aid Inlets after the drain has closed and water begins to fill the tank. You should notice sanitizer and rinse aid intermittently dripping.
8. Your glasswasher is now ready for operation.

Deliming Procedure

When the interior is coated with a white chalky substance, perform the following Deliming Procedure (after daily cleaning has been completed):

1. Place empty Glass Rack on drive wheel.
2. Push Start Switch.
3. Catch the detergent in a cup and dispose.
4. Pour one cup of deliming agent in the glasswasher. **WARNING!** Most deliming agents are hazardous. Follow all instructions very carefully!
5. Do not open the door until the cycle is complete.
6. Repeat steps 1 thru 5 if further deliming is necessary.
7. Cycle the glasswasher two or three times.

Trouble Shooting Guide

TROUBLE OR SITUATION	CAUSE	REMEDY
A. Unit does not run	<ol style="list-style-type: none"> 1. No power (Power light "off.") 2. Defective start switch 3. Wire connections poor, loose, or broken. 	<ol style="list-style-type: none"> 1. Check power source. 2. Replace start switch. 3. Re-crimp and/or replace wire connection.
B. Unit experiences a long delay (up to two minutes) before beginning a cycle.	<ol style="list-style-type: none"> 1. Incoming water does not reach minimum operating temperature. 	<ol style="list-style-type: none"> 1. See Thermostat Control information on page 4 and check temperature of water source.
C. Conveyor runs but holding tank not filling	<ol style="list-style-type: none"> 1. Water "off." 2. Bad water valve. 	<ol style="list-style-type: none"> 1. Turn water "on." 2. Test valve, replace if necessary.
D. Conveyor moves intermittently	<ol style="list-style-type: none"> 1. Loose belt. 	<ol style="list-style-type: none"> 1. Tighten belt by first loosening the four motor mount towards front and retighten bolts. Caution: Excessive belt tension could cause drive motor failure.
E. Water recirculating, conveyor not moving	<ol style="list-style-type: none"> 1. Obstruction in tank area 2. Conveyor not engaged with conveyor drive shaft. 3. Defective drive motor. 4. Defective or loose belt. 	<ol style="list-style-type: none"> 1. Remove obstruction. 2. Rotate conveyor until it engages. 3. Replace drive motor. 4. Replace or tighten belt.
F. Water not recirculating	<ol style="list-style-type: none"> 1. Completely plugged pump inlet screen. 	<ol style="list-style-type: none"> 1. Clean pump inlet screen.
G. Water leaking from recirculating pump housing - water on floor	<ol style="list-style-type: none"> 2. Defective recirculating pump. 1. Defective pump seal. 2. Pump housing cracked. 	<ol style="list-style-type: none"> 2. Replace recirculating pump. 1. Replace pump seal. 2. Replace housing.
H. Glasses slimy or soapy at end of cycle	<ol style="list-style-type: none"> 1. Sanitizer feed line in detergent container. 2. Improper Rinse Aid setting. 	<ol style="list-style-type: none"> 1. Clean line and place in proper container. 2. Adjust chemical setting (see page 3).
I. Recirculating water pressure low	<ol style="list-style-type: none"> 1. Spray box not latched properly. 2. Partially plugged pump inlet screen. 3. Missing or worn spray box gasket. 	<ol style="list-style-type: none"> 1. Latch spray box properly. 2. Clean pump inlet screen. Refer to cleaning instructions. 3. Replace gasket.
J. Detergent, sanitizer, and/or rinse aid not feeding properly	<ol style="list-style-type: none"> 1. Chemical container is empty. 2. Feed lines will not fill. 	<ol style="list-style-type: none"> 1. Refill or replace container(s). 2. Replace defective parts. Notes: The detergent, sanitizer, or rinse aid product advances in the line on each stroke of the pump. The product should hold position between strokes. If the product falls back toward the supply container, one or more of the following conditions may exist: <ol style="list-style-type: none"> a. Debris in pump, b. Split feed line, or c. Bad pump tube. Replace parts as necessary.
K. Poor washing results	<ol style="list-style-type: none"> 1. Clogged spray nozzles and dirty holding tank. 2. Detergent container empty. 3. Poor water conditions. 4. Chemicals not adjusted properly. 5. No hot water. 	<ol style="list-style-type: none"> 1. Clean unit. See cleaning instructions. 2. Fill container. 3. Have filter or softener installed. 4. Call chemical technician. 5. Check temperature of water source.

Terms and Conditions

Prices:

All prices are LIST. Applicable taxes will be added.

Quotations:

Unless otherwise stated, quotations are effective for 30 days only.

Acceptance:

All orders are subject to acceptance by Glastender, Inc.'s headquarters in Saginaw, Michigan. Possession of the Product Directory and Price List is not an offer to sell.

Shipments:

F.O.B. factory in Saginaw, Michigan. Freight terms are Third Party or Collect if shipped directly to you. Prepay and Add to Invoice freight terms are available upon request. The approximate shipping weights of all products are listed with the prices. Partial shipments will be made unless otherwise specified by the customer. Surface freight classifications are:

- GT-24/GT-30/GW24 Glasswashers - Class 175
- GT-18 Glasswashers - Class 175
- All Underbar Equipment - Class 175
- Bar Die Orders – Class 250
- Portable Bars - Class 175
- Remote refrigerators (i.e., no compressor) or dry storage back bar equipment - Class 175
- Self-contained refrigeration equipment - Class 150
- Ice Display Units (IDU and GDU) - Class 175
- Lighted Liquor Displays - Class 175
- Beer line chillers and beer towers (beverage dispensing equipment) - Class 175
- Bottle Disintegration System - Class 150
- Ice Cream Freezers - Class 125

All small items are evaluated to see the most cost effective means for shipment. Many small items ship via UPS or FedEx; however, when dimensional weight is excessive, LTL carriers are the most cost effective choice. Spare parts orders received before 1:00 PM EST can usually be shipped the same day.

The order department is happy to assist with routing or shipping questions.

Payment Terms:

Cash should be included with all orders unless credit terms have been arranged. To establish credit, banking and trade references are required. A convenient credit application is available upon request. Payment via credit card is not our normal means of receiving payment. Visa and MasterCard will be accepted, but must be charged at the time of shipment. In addition, a payment via credit card for orders totaling more than \$500 will incur a 3% convenience fee on the total transaction amount.

Delivery:

The majority of equipment is manufactured to order and typically ships within three to six weeks after complete order information is received by the factory. In-stock equipment typically ships within two to three days of the factory receiving complete order information.

Returns:

Items specified as "Manufactured to Order" are NOT returnable. A Return Authorization number must be issued by the factory in advance for any items that are returnable. The number MUST be noted on the outside of the returned package. Returns must be received within 90 days of the issue date. Shipping charges must be prepaid. A minimum 20% restocking charge will be applied to all authorized returns if received in new, unused condition in the original packaging.

The above conditions apply to spare part returns, except spare part returns must be received within 30 days of original shipment for electronic or electrical parts or within 90 days for all other parts.

Loss or Damage:

For customer routed shipments, Glastender, Inc. is not responsible for any loss, damage, or delay of merchandise during shipment. Such transit claims must be filed with the carrier. Merchandise must be examined on arrival. If shortages occur, Glastender,

Inc. must be notified in writing within five (5) days of delivery to honor any shortage claim. Glastender will assume responsibility for freight claims on Prepay and Add shipments but the customer must inspect freight and note any damage upon receipt. Failure to do so may result in losses at the customer's expense.

Custom Orders:

Custom orders must be paid in advance and are not subject to cancellation.

Laminates:

Some products include common, readily available plastic laminates of the customer's selection. There may be an additional charge if uncommon varieties are ordered.

Glastender Freight Program

Program Conditions

Glastender, Inc. equipment pricing includes standard freight costs under the following conditions:

- Equipment order is for a minimum of \$2,500, shipped to a single destination at the same time.
- Freight carrier is selected by Glastender, Inc. and may vary based on destination, transit times, performance history, customer service, or other factors.
- Shipping destination is within the continental United States and Canada. Non-continental or other international destinations are shipped to port of export.
- Combining equipment orders is allowed to reach the minimum order level if combined orders are shipped to the same destination at the same time.
- Equipment order terms of sale are FOB Saginaw MI / Freight Prepaid.
- Equipment returns are not covered.
- Parts orders do not qualify and will be charged shipping accordingly.

Customer Responsibilities

In addition to the program conditions listed above, the receiving customer must:

- Note all damage on the delivery receipt at the time of delivery.
- Open and inspect any items that look suspicious or raise concern, even if the carrier tells you it is not allowed.
- Refuse only the damaged items and keep the other items on the order.
- When in doubt, sign the delivery receipt as damaged.

The only way to hold the carrier liable is to sign the delivery as damaged.

Additional Fees

Additional carrier-related services and fees over and above standard freight costs are not covered. Such services and fees will be invoiced at the time of order or after the order has shipped.

Examples of additional fees include the following:

Split shipment.....	Cost difference between single shipment and split shipment
Lift gate.....	\$55 (Only available for items under 96" in total packaged length)
Inside delivery.....	\$100 per pallet/piece
Residential delivery	\$100
Limited access site	\$100
Expedited delivery	Difference from standard rate
Special delivery time.....	Carrier rate
Storage	Carrier rate
Re-delivery.....	Carrier rate
Re-consignment.....	Carrier rate
Other additional services not listed...	Carrier rate

Questions

For questions regarding the Glastender Freight Program, please contact Shipping & Receiving:

Steve Gunn, Shipping & Receiving Supervisor
989.752.4275, ext 141 • sgunn@glastender.com

11/14/2023

Warranty Statement

APPLICABLE TO ALL PRODUCTS SOLD WITHIN THE UNITED STATES AND CANADA

Glastender, Inc. warrants all products to be free of defects in material and workmanship. One-year labor and parts warranty applies to all glasswashers, self-contained refrigeration models, and BDS model bottle disintegration units. In established areas, a start up is included with GT-24 and GT-30 model glasswashers. Warranty is effective for one year from the date of installation or up to 18 months from date of factory shipment, whichever occurs sooner. Glastender, Inc. will replace any part or assembly found defective under normal use and service.

For warranty labor claims beyond 12 months from the date of factory shipment, proof of date of installation or occupancy must be provided. Authorization for labor must be obtained from Glastender within the warranty period and prior to the service being performed.

Labor warranty applies to the 50 states of the USA and Canada only.

Remote refrigeration models exclude the labor warranty for the condensing unit and issues related to the field installation and test of the completed refrigeration system, provided by others.

Field replacement parts not covered under the original warranty include a 90-day part warranty from the date of installation.

FOUR YEAR ADDITIONAL COMPRESSOR WARRANTY

Glastender will warrant to the original user the compressor for all self-contained refrigeration models for an additional four years following the regular one-year warranty period. This plan applies to the compressor only.

A completed warranty claim form **MUST** accompany all returned defective parts or assemblies. Upon request, a defective part or assembly must be returned to Glastender, Inc., Saginaw, Michigan, with all transportation and delivery charges prepaid. Warranty repairs or replacements will be shipped FOB factory in Saginaw, Michigan. Reimbursement for applicable freight charges covers ground service only.

Glastender provides in-warranty repairs during a service company's regular working days and hours. There is no provision for payment of a premium rate during "overtime" hours. When warranty service is requested during other than normal working hours, the end user will be charged the premium portion of the overtime rate.

The warranty covers substantiated travel expenses for up to 2 hours / 100 miles round trip up to a maximum of \$225. Any additional costs due to installations that require extra work, time, or travel to gain access for service are the sole responsibility of the equipment purchaser. Any exceptions to these travel and access limitations must be pre-approved by a factory representative.

The warranty does not cover door gaskets, chemical tubing, pump squeeze tubing, and/or any equipment subjected to accidents, freight damage, alterations from the original design, improper power and/or plumbing hookups, improper chemical use, general misuse, or lack of routine required maintenance as determined by Glastender, Inc. Installation, normal control adjustments, general maintenance, correcting an installation error, or service calls that reveal the unit is functioning normally will not be reimbursed under warranty.

Condenser coils on self-contained refrigeration products must be cleaned regularly. Failure to provide adequate air flow to a refrigeration unit will void the warranty.

Glastender shall not be liable for loss of use, revenue, or profit, or for any other indirect, incidental, special, or consequential damage including, but not limited to, product spoilage or loss.

This warranty is conditioned upon Glastender receiving notice of any defect subject to this warranty within sixty (60) days of its discovery by the end user or dealer. All products are warranted only for the initial place of installation. Removal of a product automatically terminates this warranty.

SECOND YEAR EXTENDED PARTS & LABOR WARRANTY

Glastender's one-year parts and labor warranty on self-contained refrigeration units can be extended to two years with the purchase of a two year parts and labor warranty. Specify part number EWR2 (\$250 net price) when ordering.

EXPORT WARRANTY - One year parts only.

EXCLUSION OF WARRANTIES

EXCEPT AS PROVIDED ABOVE, GLASTENDER MAKES NO WARRANTIES, EXPRESS OR IMPLIED, INCLUDING, BUT NOT LIMITED TO, ANY IMPLIED WARRANTY OF MERCHANTABILITY, FITNESS FOR A PARTICULAR PURPOSE OR NON-INFRINGEMENT.

LIMITATION OF REMEDIES AND DAMAGES

If Buyer makes a valid and timely claim as outlined above, Glastender's liability and Buyer's remedies under this agreement will be limited solely to labor charges authorized and/or replacement or credit, at Glastender's option, with respect to Products returned at Buyer's expense within thirty (30) days after warranty repair. GLASTENDER'S LIABILITY WILL IN NO EVENT BE GREATER IN AMOUNT THAN THE PURCHASE PRICE OF THE RETURNED PRODUCTS. GLASTENDER WILL NOT BE LIABLE UNDER ANY CIRCUMSTANCE FOR CONSEQUENTIAL OR INCIDENTAL DAMAGES, INCLUDING, BUT NOT LIMITED TO, LABOR COSTS EXCEPT AS COVERED UNDER OUR WARRANTY, LOST PROFITS OR THE LOSS OF PERISHABLE PRODUCTS RESULTING FROM THE USE OF OR INABILITY TO USE OUR PRODUCTS OR FROM OUR PRODUCTS' INCORPORATION INTO OR BECOMING A COMPONENT OF ANY OTHER PRODUCT. NEITHER PARTY WILL HAVE ANY NEGLIGENCE OR OTHER TORT LIABILITY TO THE OTHER, OR TO ANY THIRD PARTY, ARISING FROM ANY BREACH OF THIS AGREEMENT.

GOVERNING LAW - JURISDICTION

The terms and conditions of an order are to be governed and construed according to the laws of the State of Michigan, without regard to conflict of laws principles. Buyer hereby consents to the jurisdiction and venue of the courts located in Saginaw County, Michigan.

No representative, distributor, dealer, or any other person is authorized to modify this warranty. This warranty replaces all other written or verbal warranties.

NOTE: Glastender, Inc.'s policy of constant quality improvement means that prices, specifications, and policies are subject to change without notice. Questions regarding this warranty should be directed to Glastender's Warranty Administrator.

02-16-23

IMPORTANT!!

Attention Service Companies

Please review the important warranty information on this page. If you believe a service call should be covered by the factory, please call the factory for authorization between 8AM and 5PM EST, Monday through Friday.