

# Glastender®

A family company manufacturing in the USA

[www.glastender.com](http://www.glastender.com)



F1SL24  
with compressor right,  
black vinyl-clad glass door,  
and stainless steel top



Capable of storing  
specialty cocktail ice

### CONFIGURATION HIGHLIGHTS



### Standard Features

- Locking door(s)
- Self-contained high capacity refrigeration system
- Digital thermostat control with automatic defrost is easily visible
- Two Defrost Cycles:
  1. Automatic - occurs every eight hours without affecting normal operation
  2. Manual - user initiated button for complete six-hour defrost with automatic restart
- All stainless steel interior
- Three adjustable shelves per door
- Includes LED interior lights with on/off switch
- Available without a finished top for integrated installation below customer supplied bar top
- Automatic condensate evaporator
- Eco friendly foamed-in-place insulation has zero impact on global warming or ozone depletion
- Front of cabinet is electrically heated
- Any door section may be converted to two drawers
- Optional glass door(s) are triple pane, low E, Argon filled

### Specifications

#### Electrical

- 120V, 1 phase, 60 Hz, 5.0 full load amps
- Dedicated 15 amp circuit is required
- Includes a 6 foot NEMA 5-15P grounded cord and plug which exits the back of refrigeration compartment

#### Refrigeration

- 1/3 HP, R290 refrigerant - 110 grams
- Heat rejection - 2048 BTU/Hr
- Operating range: 12°F (-11°C) to 35°F (2°C)
- Fin & tube evaporator with forced air circulation
- Equipped with manual fast freeze mode that accelerates the freezing process and automatically reverts back to the normal operating mode



Project: _____	AIA# _____
Item #: _____ Qty: _____	SIS# _____
Model #: _____	

## Frosters, One Zone, Side Serviced, Low Profile

F1SL24, F1SL28, F1SL36, F1SL44, F1SL48

### F1SL Configurable Options

#### Refrigeration Compartment Location:

- Left or Right

#### Refrigeration Compartment Cover Finish:

- Black vinyl-clad
- Stainless steel
- Jeweled stainless

#### Door/Drawer Style & Finish:

- Door - Black vinyl-clad
- Door - Unlaminated
- Door - Stainless steel
- Door - Jeweled stainless
- Door - Laminated
- Door - Glass, black vinyl-clad
- Door - Glass, stainless steel
- Door - Glass, jeweled stainless
- Door - Glass, laminated
- Drawers - Black vinyl-clad
- Drawers - Stainless steel
- Drawers - Jeweled stainless
- Drawers - Laminated

See our Product Directory for a complete list of cooler accessories.

#### Door Hinge Location (specify for each door):

- Left or Right

#### Door Handle:

(Note: drawers come with a stainless pull tab handle)

- Polished stainless
- Polished brass
- Stainless pull tab

#### Top Style:

- No finished top
- Stainless top
- Laminated top
- Drainboard top

#### Left and Right Side Finish:

- Black vinyl-clad
- Stainless steel
- Laminated

#### Back Finish:

- Galvanized steel
- Stainless steel

#### LED Lighting Style:

- Bright white (7,000k)
- Warm white (3,500k)
- Blue



Intertek

EP 5016978

Energy Performance  
Verified / Rendement  
Énergétique Vérifié



Intertek

4004503  
Conforms to NSF/ANSI STD 7  
and UL STD 471

Certified to CSA STD C22.2 No. 120



Intertek

#### Plumbing

- Automatic condensate evaporator. No drain connection required
- Optional drainboard top - 1/2" ID line stubs out behind the compressor compartment. Field connections must be made at that point.

#### Shelving

- Three adjustable coated shelves included

#### Legs

- Optional 6" legs, specify accessory #CLS-4
- 1-5/8" diameter
- Stainless steel bullet feet

#### Materials

- Stainless steel parts include: exterior sub-top, interior, front of cabinet, exterior sides, hinges, hinge and lock brackets, and optional legs
- Black vinyl-clad steel parts include: standard doors and compressor cover
- Galvanized steel parts include: back and bottom
- Zinc plated CR steel parts include: leg sockets

Glastender, Inc. • 5400 N Michigan Rd • Saginaw, MI • 48604-9780  
989.752.4275 • 800.748.0423 • Fax 989.752.4444  
[www.glastender.com](http://www.glastender.com)

Approval/Notes:

Specifications subject to change without notice. For current specifications please visit our website.

# Frosters - One Zone, Side Serviced, Low Profile

## Dimensional Information

### PLAN VIEWS

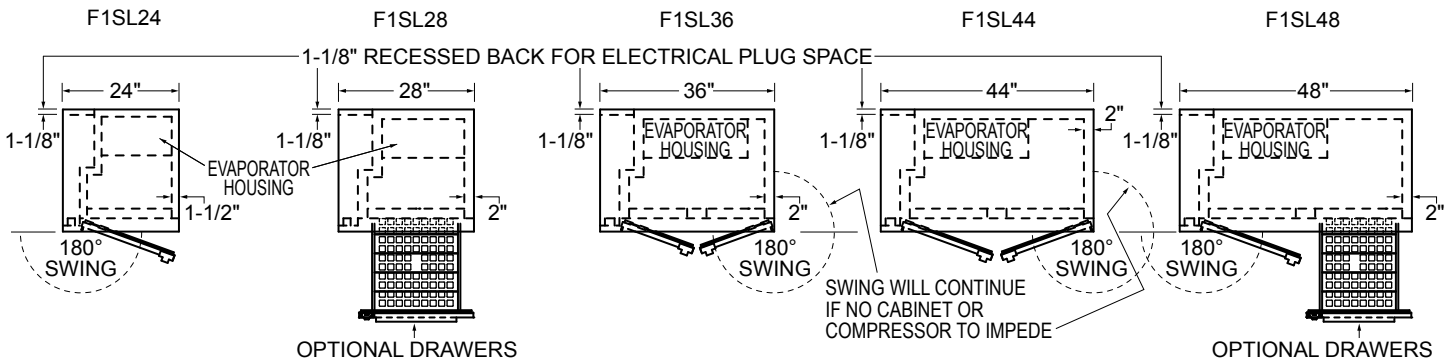

### FRONT VIEWS

\*ADD 1" HEIGHT TO TOP FOR FACTORY INSTALLED TOP

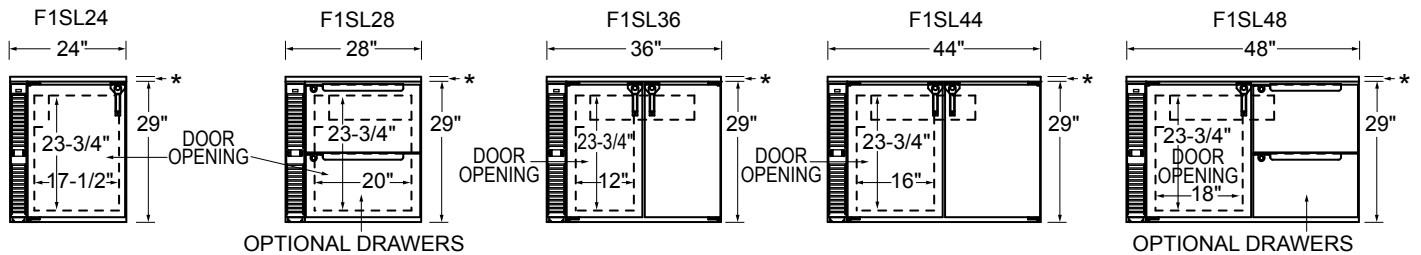

### SIDE VIEWS

\*ADD 1" HEIGHT TO TOP FOR FACTORY INSTALLED TOP

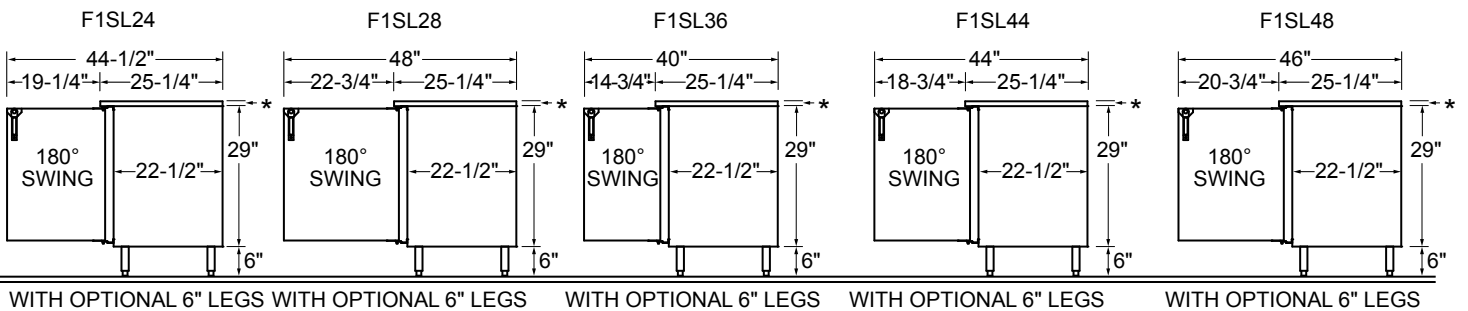

Note: Available with compressor left or right. Compressor left model shown.

Model	Doors	Capacities	
		10 oz. Mugs	6" High Pint Glasses
F1SL24	1	101	72
F1SL28	1	123	75
F1SL36	2	171	115
F1SL44	2	231	151
F1SL48	2	261	169

### SIDE VIEWS

