



Electrolux

Food Processor K180-Vertical Cutter-Mixer 4.5gal (18.5qt), 2 speed-s/s bowl

ITEM # _____

MODEL # _____

NAME # _____

SIS # _____

AIA # _____



Food Processor

K180-Vertical Cutter-Mixer 4.5gal (18.5qt), 2 speed-s/s bowl

600087 (K180S2U)

K180FU S/S CUTTER-MIXER
18.5QT

Short Form Specification

Item No. _____

K180FU-Vertical Cutter/Mixer, bench-style, two speed, 18.5 quart bowl capacity, removable bowl design, stainless steel bowl with clear lexan lid, metal housing, 1800 or 3600 rpm, 4-3/4 HP, 208-240v/60/3, 13.9 amps



APPROVAL: _____

Main Features

- Cutter mixer allows fast liquidizing, mixing, mincing, chopping and pastry-making.
- Lid with opening to add ingredients in mid-cycle.
- Base fixed cover for a better handling.
- Pulse function to coarse chopping.
- Productivity suitable for 100-300 meals per service, up to 18lbs (8kg) per cycle.
- Delivered with:
 - 4.5gal (18.5qt or 17.5lt) stainless steel bowl with max liquid level indication to avoid spillage
 - micro toothed perforated blade
 - scraper
- Angled perforated knives and conical base of the bowl ensure consistent mixing.
- Cover metal frame to ensure seal water tightness to avoid leakage.
- All parts in contact with food are removable without tools and dishwasher safe.

Construction

- 2 speeds: 1500 and 3000 rpm.
- IP65 touch button control panel.
- Transparent polycarbonate cover incorporates a magnetic contact safety system.
- Power: 3600 watts.
- 304 AISI stainless steel bowl with leak resistant spout and handles, easy to manage.
- Scraper with Stainless Steel handle, easy to dismount.
- Cover handle with double safety locking system.
- For user safety, user is required to press the start button to restart the machine after a power cut off.
- Asynchronous silent industrial motor for heavy duty and longer life.

Included Accessories

- 1 of Scraper for K180S and KE180S cutter PNC 650046 mixers
- 1 of Microtoothed blade rotor for 17,5 lt PNC 650047 cutter mixer
- 1 of Bowl, 18.5 quart, for cutter/mixer, PNC 650074 stainless steel

Optional Accessories

- Scraper for K180S and KE180S cutter PNC 650046 mixers
- Microtoothed blade rotor for 17,5 lt cutter PNC 650047 mixer
- Bowl, 18.5 quart, for cutter/mixer, PNC 650074 stainless steel
- Mobile stand, stainless steel PNC 653017
- Blade Rotor, smooth, for 18.5 quart PNC 653119 cutter/mixer
- Blade rotor, serrated, for 18.5 quart PNC 653120 cutter/mixer



Electrolux

K180-Vertical Cutter-Mixer 4.5gal (18.5qt), 2 speed-s/s bowl

Food Processor

Electrolux Professional, Inc.

www.electroluxusa.com/professional

10200 David Taylor Drive, Charlotte, NC 28262 • Telephone Number: 866-449-4200 • Fax Number: 704-547-7401



Electrolux

**Food Processor
K180-Vertical Cutter-Mixer 4.5gal
(18.5qt), 2 speed-s/s bowl**

- Serrated blade rotor for meat for 17,5 lt cutter mixer PNC 653539
□



Electrolux

**Food Processor
K180-Vertical Cutter-Mixer 4.5gal
(18.5qt), 2 speed-s/s bowl**

Front

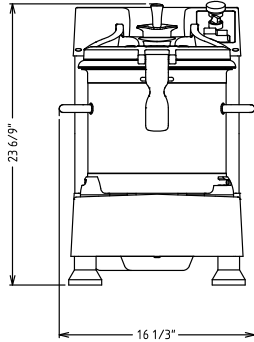

Top

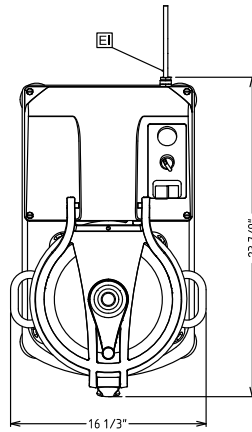

EI = Electrical connection

Side

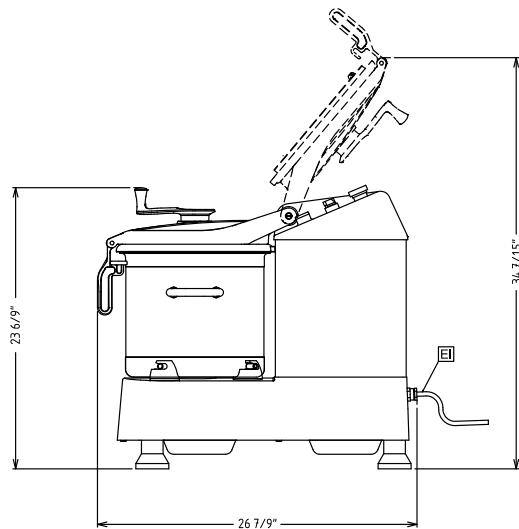

Electric

Supply voltage:

600087 (K180S2U) 208-240 V/3 ph/60 Hz

Electrical power, max:

3.6 kW

Total Watts:

3.6 kW

Key Information:

External dimensions, Width: 16 3/8" (416 mm)

External dimensions, Depth: 25 15/16" (658 mm)

External dimensions, Height: 23 3/4" (603 mm)

Shipping width: 21 5/8" (550 mm)

Shipping depth: 31 1/2" (800 mm)

Shipping height: 31 1/2" (800 mm)

Shipping weight: 165 lbs (75 kg)

**Food Processor
K180-Vertical Cutter-Mixer 4.5gal (18.5qt), 2 speed-s/s bowl**

The company reserves the right to make modifications to the products without prior notice. All information correct at time of printing.

2017.01.10