



Electrolux

EMPower Four (4) Open Gas Burner Range with 24" " Static Oven Base with Safety Thermocouple

ITEM # _____

MODEL # _____

NAME # _____

SIS # _____

AIA # _____



EMPower

Four (4) Open Gas Burner Range with 24" " Static Oven Base with Safety Thermocouple

169134 (ACFG24T)

EMPower Restaurant Range, gas, 24" wide, (4) 33,000 BTU (164,000 BTU total) open burners, static oven base with (2) stainless steel tray racks with (6" adjustable, removable legs)

Short Form Specification

Item No. _____

Unit to be Electrolux Four (4) Open Gas Burner Range with Static Oven. Individually controlled high efficiency 32,500 BTU (9.5 kW) Flower Flame burners. Control knobs provide smooth, continuous rotation from min to max. Suitable for natural gas or propane gas. Cast iron pan supports 12" x 12" (305 mm x 305 mm). Full width crumb tray below the burners. Special heavy duty chrome plated knobs for durability and easy cleaning. The configuration of bezels and knobs provides high level of protection against water infiltrations. Right-angled side edges to allow flush fitting between units. Supplied with 6" (150 mm) height adjustable, removable legs. Unit may be installed on castors. 24" (610 mm) static oven 34,000 BTU/hr (10 kW) with unique baffle above the burner distributes heat to provide even cooking temperatures throughout the cavity. Vitreous enamelled oven interior accommodates two standard Imperial full size 18" x 26" (457 mm x 660 mm) sheet pans. The interior is 19-1/2" w x 26-3/4" d x 15" h (497 mm w x 680 mm d x 380 mm h). 100% safety pilot. Manual oven shut-off valve. Heavy duty thermostat with temperature range from 158°F to 590°F (70°C to 310°C). Oven supplied with two stainless steel tray racks.

Construction

Open Burner Information:

- Four (4) individually controlled high efficiency 33,000 BTU (9.5 kW) Flower Flame gas burners.
- Control knobs provide smooth, continuous rotation from min to max.
- No gaskets and removable one-piece venturis and burners for easy cleaning.
- The geometrics of the venturis and cast iron burners provides the maximum level of heating efficiency.
- The cast iron burners are anti-clogging.
- The cast iron pan supports 12" x 12" (305 mm x 305 mm), thanks to the special configuration, allow for even small pots and pans to be placed over the flame.
- The cast iron pan supports allow to slide pots and pans from section to section as well as to protect the pilot from spilled food and debris.
- Full width crumb tray below the burners captures all overflow and debris and can be easily extracted for dumping and cleaning.
- Unit with thermocouple and flame failure device protects against accidental extinguishing of the flame (model # 169038).

Oven Information:

- 24" (610 mm) static oven 34,000 BTU/hr (10 kW) with unique baffle above the burner distributes heat to provide even cooking temperatures throughout the cavity.
- Vitreous enamelled oven interior accommodates two standard Imperial full size 18" x 26" (457 mm x 660 mm) sheet pans.
- The interior is 19-1/2" w x 26-3/4" d x 15" h (497 mm w x 680 mm d x 380 mm h).
- 100% safety pilot.
- Manual oven shut-off valve.
- Heavy duty thermostat with temperature range from 158°F to 590°F (70°C to 310°C).
- Oven supplied with two stainless steel tray racks.

- General Information:
- Worktop in AISI 304 Stainless Steel.
 - Front and side panels in Stainless Steel with Scotch Brite finish.
 - Special heavy duty chrome plated knobs for durability and easy cleaning.
 - The configuration of bezels and knobs provides high level of protection against water infiltrations.
 - Right-angled side edges to allow flush fitting between units.
 - Provided with kit for side-by-side connection between units for minimizing gaps and possible dirt traps.
 - Supplied with 6" (150 mm) height adjustable, removable legs.
 - Unit may be installed on castors.
 - Included Accessories: propane converter kit, pressure



APPROVAL: _____

Electrolux Professional, Inc.

www.electroluxusa.com/professional

10200 David Taylor Drive, Charlotte, NC 28262 • Telephone Number: 866-449-4200 • Fax Number: 704-547-7401



Electrolux

Four (4) Open Gas Burner Range with 24" Static Oven Base with Safety Thermocouple

EMPower



Electrolux

**EMPower
Four (4) Open Gas Burner Range with 24
" Static Oven Base with Safety Thermocouple**

regulator and main shut off valve.

Optional Accessories

- EMPower Restaurant Range Shelf Support 24". Can be mounted on EMPower Open Gas Burner Tops and Gas Burner Ranges. PNC 169078
- EMPower back mounted rear shelf-spacer, 24" unit PNC 169098
- Portioning Shelf 12" PNC 169173
- Portioning Shelf 16" PNC 169174
- Portioning Shelf 24" PNC 169175
- Kit 4 wheels - 2 swivelling with brake - it is mandatory to install base support and wheels PNC 206135

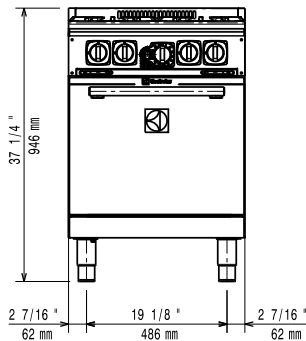
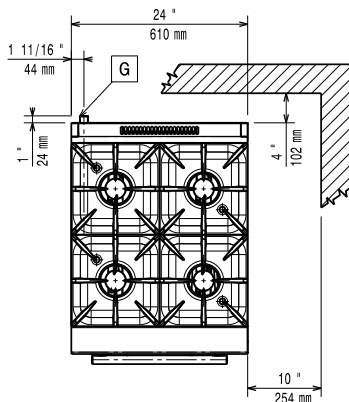
Front

Top

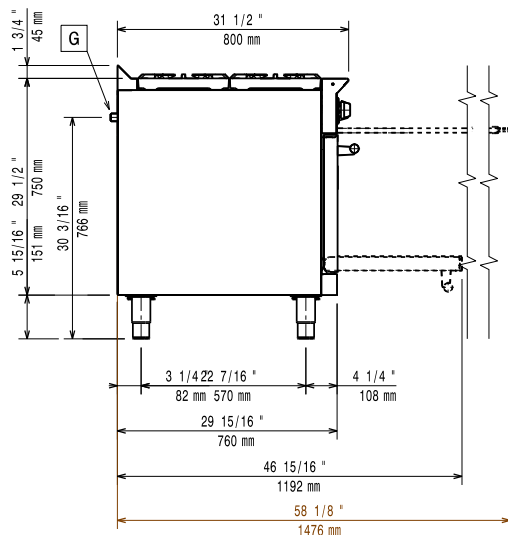
EQ = Equipotential screw
G = Gas connection

Side

Gas

Gas Power:	169134 (ACFG24T)	164000 Btu/hr (48 kW)
Gas Power:		164000 Btu/hr (48 kW)
Gas Type Option:		Propane
Gas Inlet:		1/2"

Key Information:

Front Burners Power:	9.5 - 9.5 kW (32385.5 - 32385.5 Btu/hr)
Middle Burners Power:	0 - 0/0 - 0 kW (0 - 0/0 - 0 Btu/hr)
Front Plates Power:	9.5 - 9.5 kW (32385.5 - 32385.5 Btu/hr)
Back Plates Power:	9.5 - 9.5 kW (32385.5 - 32385.5 Btu/hr)
Oven working Temperature:	158 °F (70 °C) MIN - 590 °F (310 °C) MAX
Oven Cavity Dimensions (width):	19 9/16" (497 mm)
Oven Cavity Dimensions (depth):	26 3/4" (680 mm)
Oven Cavity Dimensions (height):	14 15/16" (380 mm)
External dimensions, Width:	24 1/32" (610 mm)
External dimensions, Depth:	31 1/2" (800 mm)
External dimensions, Height:	37 3/16" (945 mm)
Net weight:	282 lbs (128 kg)
Shipping width:	35 7/8" (911 mm)
Shipping depth:	26 11/16" (678 mm)
Shipping height:	45 7/16" (1154 mm)
Shipping weight:	309 lbs (140 kg)
Shipping volume:	25.17 ft ³ (0.71 m ³)

* The rear and side clearances shown on the diagram indicate the minimum distances recommended from the appliance to combustible surfaces.