

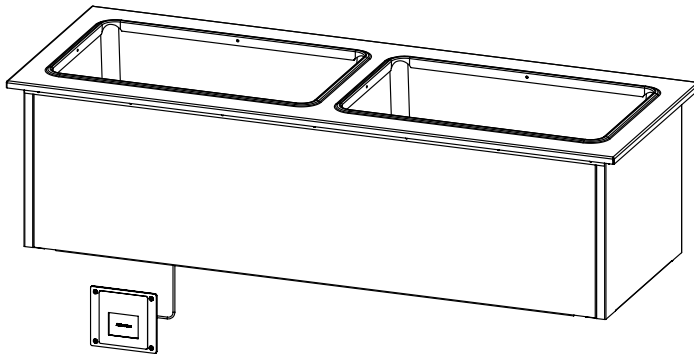

Your Solutions Partner

Specifications

F.O.B. Sedalia, Missouri 65301



Model WWG2-SL Shown Above

OPTIONS:

- Designer Foodshields
- Telescope covers
- Adapter Plates
- Adapter Bars

Agency Listings:



NSF/ANSI 4

DUKE MANUFACTURING CO.

2305 N. Broadway

St. Louis, MO 63102

800.735.3853 Toll Free

314.231.5074 Fax

www.dukemfg.com

SS-1268 Drop In Slimline Ganged Waterless Well

Approval Stamp(s):

PRODUCT INFORMATION:

PROJECT: _____

ITEM: _____

QUANTITY: _____

MODEL:

Drop-Ins - Hot Food

Electric Ganged Waterless Well

- WWG1-SL 24 1/4"L x 17 1/4"W x 12 3/4"H
- WWG2-SL 46 1/4"L x 17 1/4"W x 12 3/4"H
- WWG3-SL 68 1/4"L x 17-1/4"W x 12 3/4"H

BODY:

- Heavy gauge, 300 Series stainless steel top
- Overhang on front, back and ends w/locking tabs
- Vinyl foam gasket as sealant
- Die-stamped openings - 11-7/8" X 19-7/8"

Heat Compartments:

- Voltage/Phase/Watt
 - 120 Volt/1 Ph/665 watt element
 - 208 Volt/1Ph/500 watt element
 - 240 Volt/1Ph/665 watt element
- 6-1/4" deep stainless steel liner for dry operation only
- Includes Silicone bottom pad
- Fully Insulated
- Rope element in each compartment

CONTROLS:

- Standard intuitive, easy to use touch screen control - One control for all wells
- Easily adjusted presets LOW/MED/HIGH
- Built in WIFI and Bluetooth for future connectivity.

EXTERIOR HOUSING:

- Heavy gauge paint grip steel

Specification subject to change



Drop-In Slimline Ganged Waterless Well

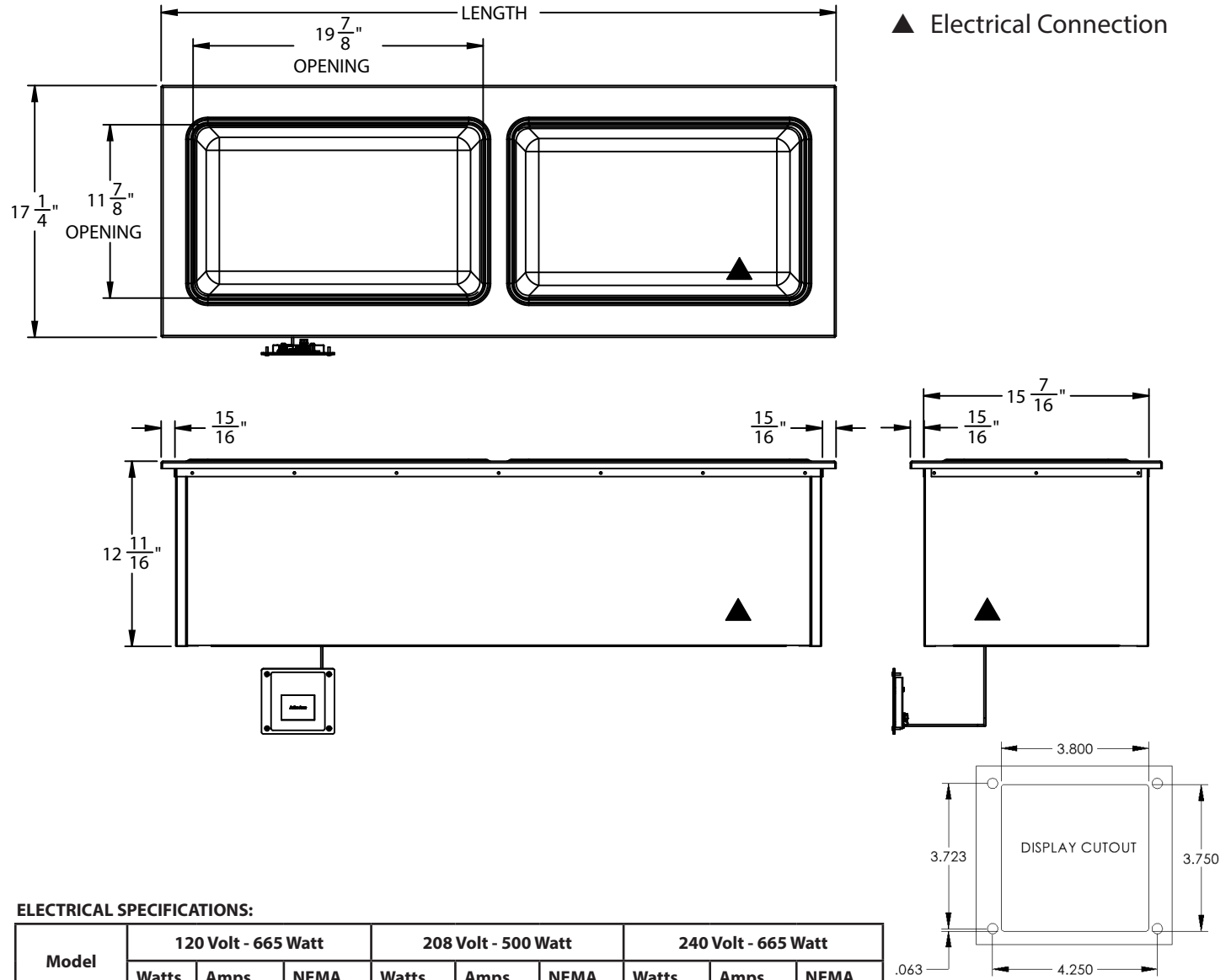

▲ Electrical Connection

ELECTRICAL SPECIFICATIONS:

Model	120 Volt - 665 Watt			208 Volt - 500 Watt			240 Volt - 665 Watt		
	Watts	Amps	NEMA	Watts	Amps	NEMA	Watts	Amps	NEMA
WWG1-SL	665	5.5	5-15	500	2.4	6-20	665	2.8	6-20
WWG2-SL	1330	11.1	5-15	1000	4.8	6-20	1330	5.5	6-20
WWG3-SL	1995	16.6	L5-30	1500	7.2	6-20	1995	8.3	6-20

DIMENSIONS:

Freight Class: 100

Model	Length		Width		Height		Cutout Length		Cutout Width		Cube ft. Crated	Crated Ship Weight	
	in	cm	in	cm	in	cm	in	cm	in	cm		lbs	kg
WWG1-SL	24.25	61.6	17.25	43.8	12.75	32.4	23.	58.4	16	40.6	7.7	80	36.4
WWG2-SL	46.25	117.5	17.25	43.8	12.75	32.4	45	114.3	16	40.6	13.3	135	61.4
WWG3-SL	68.25	173.25	17.25	43.8	12.75	32.4	67	170.2	16	40.6	19.0	185	84.1



Duke Manufacturing Co.
 2305 N. Broadway
 St. Louis, MO 63102

Phone: 314-231-1130
 Toll Free: 1-800-735-3853
 Fax: 314-231-5074

www.dukemfg.com