

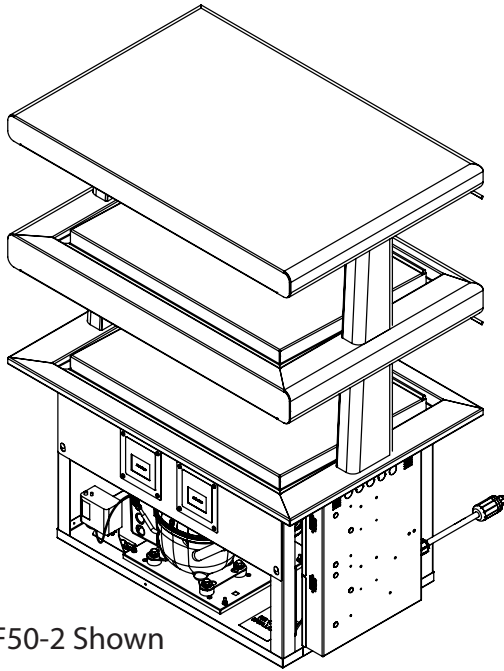

Your Solutions Partner

Specifications

F.O.B. Sedalia, Missouri 65301



HF50-2 Shown

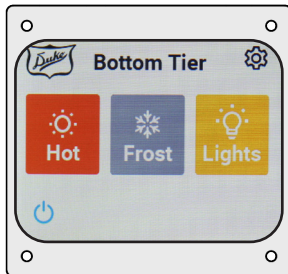

Duke's full color touch screen control with preset temperatures

OPTIONS:

- Available in cold only.
- 72" or 96" Display cables for remote mounting.

DUKE MANUFACTURING CO.
 2305 N. Broadway
 St. Louis, MO 63102
 800.735.3853 Toll Free
 314.231.5074 Fax
 www.dukemfg.com
 SS-1056 2 Tier Hot Frost

Approval Stamp(s):

Merchandiser - HotFrost™

PRODUCT INFORMATION:

PROJECT: _____

ITEM: _____

QUANTITY: _____

MODEL:

HotFrost™ Dual Tier Merchandiser - Sheet pan format

- HF35-2 1ea. 18X26 Sheet Pan/Tier
- HF48-2 2ea. 18X13 Sheet pans/Tier
- HF50-2 3ea. 18x13 Sheet Pans/Tier
- HF64-2 2ea. 18X26 Sheet Pans/Tier
- HF91-2 3ea. 18x26 Sheet Pans/Tier

Features:

- Switch from Hot or Cold display merchandising as your menu dictates.
- Change your serving configuration daily and from breakfast to lunch as your menu dictates.
- Recessed HotFrost Drop in with HotFrost shelves integrated into the breathguards double food display merchandising per linear foot.
- Change the way food is served and merchandised with pre-plated and pre-portioned foods.
- The sheet pan format enables fast line re-load and the ability to handle high throughput in a short period of time.

Controls:

- Intuitive, easy to learn, easy to use full color touch screen control with pre-programmed temperatures assure consistency and high food quality.
- Touchscreen shows alerts and messaging when the unit isn't operating to specification... also easy access to serial #.
- Built in connectivity to allow future firmware updates, and remote alerts, messaging and control.
- Four foot cord supplied between control and touch-screen.
- Complies with part 15 of the FCC rules.

Certifications



Specification subject to change



Catalog No. Hot Frost™

A.I.A. File No. 35-C-13

HotFrost™ Dual Tier Switchable Merchandiser

A.I.A. File No. 35-C-13

Catalog No. Hot Frost™

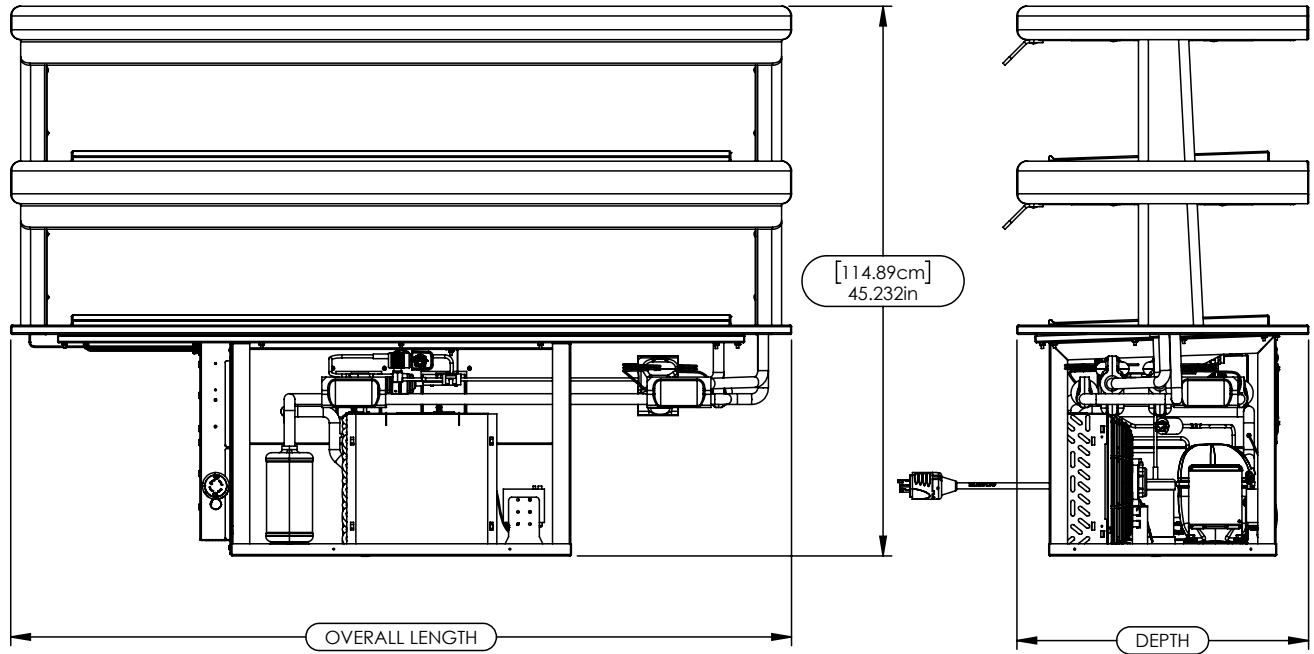

DIMENSIONS:

Freight Class: 110

Model	Overall Length		Cutout Length		Overall Depth		Cutout Depth		Crated Cubic Ft.	Crated Weight	
	in	cm	in	cm	in	cm	in	cm		lbs.	kg.
HF35-2	35.0	88.9	33.375	84.77	24.00	60.96	20.813	52.87	57.4	430	195.0
HF48-2	48.125	122.24	46.625	118.43	32.00	81.28	28.813	73.19	89.6	700	317.5
HF50-2	50.125	127.32	48.5	123.19	24.00	60.96	20.813	52.87	92.4	740	335.7
HF64-2	64.25	163.20	62.625	159.07	24.00	60.96	20.813	52.87	94.4	780	353.8
HF91-2	92.875	235.90	91.25	231.77	24.00	60.96	20.813	52.87	126.3	1000	494.4

ELECTRICAL SPECIFICATIONS:

Model	AMPS	Refrig. R448A	HFL -120/208	FOL-120
			NEMA	NEMA
HF35-2-HFL-HFL - Hot Frost	9.3	31.5oz	L14-20P	N/A
HF35-2-FOL-FOL - Frost Only	9.3	31.5oz	N/A	5-15P
HF48-2-HFL-HFL - Hot Frost	12.5	35.0oz	L14-20P	N/A
HF48-2-FOL-FOL - Frost Only	9.8	35.0oz	N/A	5-15P
HF50-2-HFL-HFL - Hot Frost	13.0	35.0oz	L14-20P	N/A
HF50-2-FOL-FOL - Frost Only	9.8	35.0oz	N/A	5-15P
HF64-2-HFL-HFL - Hot Frost	19.4	38.0oz	L14-30P	N/A
HF64-2-FOL-FOL - Frost Only	9.8	38.0oz	N/A	5-15P
HF91-2-HFL-HFL - Hot Frost	26.8	*30.5oz	14-50P	N/A
HF91-2-FOL-FOL - Frost Only	19.8	*30.5oz	N/A	L5-30P

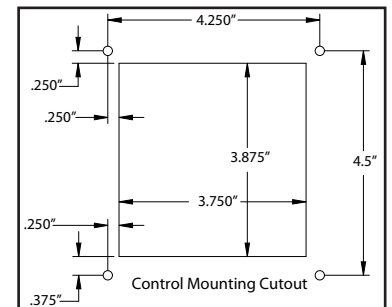
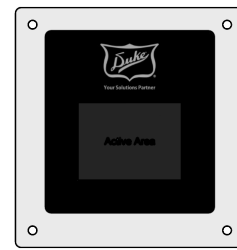
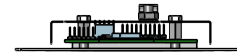

"This product may be covered by one or more patents or pending patent applications. For more details, see <http://dukemfg.com/patents>"

Merchandiser - HotFrost™



Duke Manufacturing Co.

2305 N. Broadway
St. Louis, MO 63102

Phone: 314-231-1130
Toll Free: 1-800-735-3853
Fax: 314-231-5074

www.dukemfg.com

Printed in U.S.A.
© 2022, Duke Manufacturing Co.