

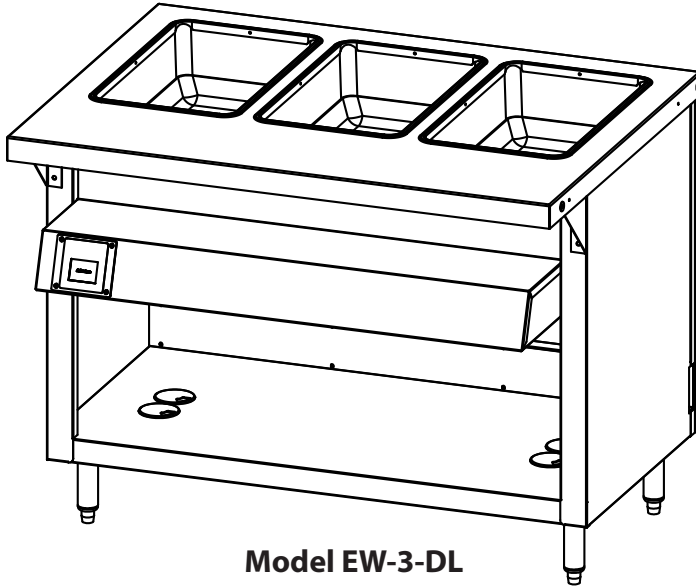

Your Solutions Partner

Specifications

F.O.B. Sedalia, Missouri 65301



Model EW-3-DL

OPTIONS:

- 14 gauge tops
- Electric heat base module
- Sliding/Hinged Doors
- Adaptor plates
- Casters (add cord and plug), 5" swivel with locks
- Veneered plastic laminate panels on body
- Powder coat paint colors
- Foodshields
- Trayslides
- 1/2" poly cutting surface added to integral top
- Kickplates S/S or paint grip
- 6', 8' or 10' Cord and plug

AGENCY LISTINGS:



DUKE MANUFACTURING CO.

2305 N. Broadway

St. Louis, MO 63102

800.735.3853 Toll Free

314.231.5074 Fax

www.dukemfg.com

Specification subject to change



WARNING For CA residents: go to www.dukemfg.com/prop65 for prop 65 warning

Approval Stamp(s):

PRODUCT INFORMATION:

PROJECT: _____

ITEM: _____

QUANTITY: _____

MODEL:

Thurmaduke® Ganged Waterless Well
Hot Food Units - Electric - Deluxe

- EW-2-DLPG/EW-2-DLSS 2 top openings
- EW-3-DLPG/EW-3-DLSS 3 top openings
- EW-4-DLPG/EW-4-DLSS 4 top openings
- EW-5-DLPG/EW-5-DLSS 5 top openings
- EW-6-DLPG/EW-6-DLSS 6 top openings

TOP:

- One piece. 16 gauge, 300 Series stainless steel
- Top openings die-stamped. 11-7/8" x 19-7/8"
- Integral carving/work surface

Heat Compartments:

- 6-1/4" deep stainless steel liner for dry operation only
- Includes Silicone bottom pad
- Fully Insulated
- Rope element in each compartment

CONTROLS:

- Standard intuitive, easy to use touch screen control - One control for all wells
- Easily adjusted presets LOW/MED/HIGH
- Built in WIFI and Bluetooth for future connectivity.

BODY AND INTERIOR SHELF:

- 300 Series stainless steel or paint grip steel
- 6" polished stainless steel adjustable legs

INTEGRAL DISHSHELF:

- Heavy gauge, one piece stainless steel - 8-1/2" wide



Ganged Waterless Well Deluxe

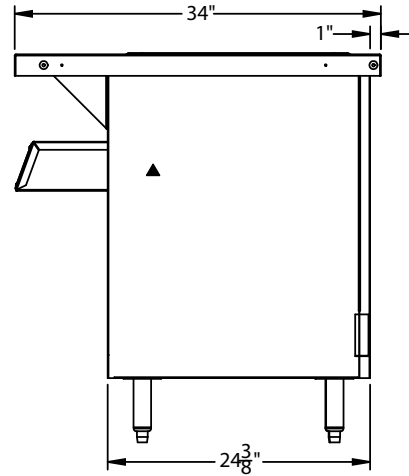
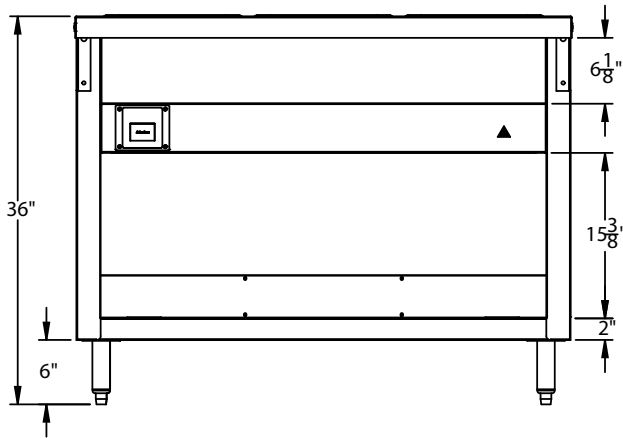
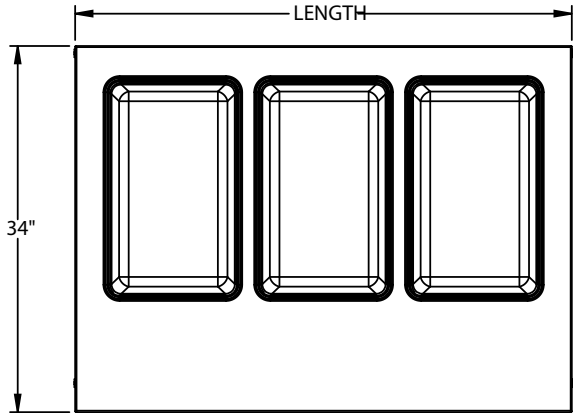
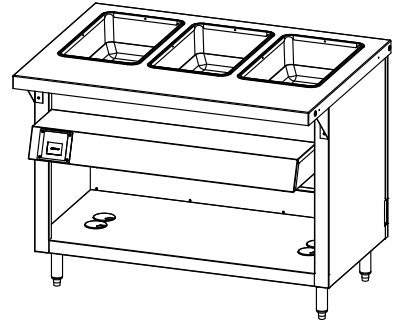

DIMENSIONS:

FREIGHT CLASS: 150

Model		Length		Width		Height		Top Openings	Cube ft. Crated	Weight	
Enameled	Stainless	in	cm	in	cm	in	cm			lbs	kg
EW-2-DLPG	EW-2-DLSS	32	81.3	34	86.4	36	91.4	2	27.0	255	115.9
EW-3-DLPG	EW-3-DLSS	46	116.8	34	86.4	36	91.4	3	38.1	335	152.3
EW-4-DLPG	EW-4-DLSS	60	152.4	34	86.4	36	91.4	4	49.2	410	186.4
EW-5-DLPG	EW-5-DLSS	74	188.0	34	86.4	36	91.4	5	60.2	495	225.0
EW-6-DLPG	EW-6-DLSS	88	223.5	34	86.4	36	91.4	6	71.3	595	270.5

ELECTRICAL SPECIFICATIONS:

Model	120 Volt - 665 watt			208 Volt - 500 watt			240 Volt - 665 watt		
	Watts	Amps	NEMA	Watts	Amps	NEMA	Watts	Amps	NEMA
EW-2-DLPG/SS	1330	11.1	5-15	1000	4.8	6-20	1330	5.5	6-20
EW-3-DLPG/SS	1995	16.6	L5-30	1500	7.2	6-20	1995	8.3	6-20
EW-4-DLPG/SS	2660	22.2	L5-30	2000	9.6	6-20	2660	11.1	6-20
EW-5-DLPG/SS	N/A	N/A	N/A	2500	12.1	6-20	3325	13.9	6-20
EW-6-DLPG/SS	N/A	N/A	N/A	3000	14.4	6-20	3990	16.6	6-20

Cord and NEMA plug NOT included



Duke Manufacturing Co.
2305 N. Broadway
St. Louis, MO 63102

Phone: 314-231-1130
Toll Free: 1-800-735-3853
Fax: 314-231-5074

www.dukemfg.com