

CONNERTON

American Engineering Since 1936

MODELS: CN-SM-36

Salamander Broiler

Counter-Top or Wall Mount or Range Mount

Standard Features

- ◉ Stainless steel exterior and interior
- ◉ Welded stainless and aluminized steel chassis
- ◉ Equipped with one large heavy-duty pre-mix atmospheric infrared ceramic burners at 35,000 BTU with high efficiency performance.
- ◉ Standing pilot ignition system.
- ◉ 1 minute pre-heat time
- ◉ Heavy-duty chrome plated grid rack and 4 position rack guides
- ◉ Removable Stainless-Steel full width spillage pan.
- ◉ 3/4" NPT rear gas connection and Standard Regulator - **One-year limited parts and labor warranty**

ACCESSORIES

- ◉ 4" chrome plated legs with Adjustable feet.
- ◉ Wall mount with mounting Bracket kit
- ◉ Range mount kits are provided with Heavy Duty Connerton Range



CONNERTON

11990 Rivera Rd, Santa Fe Springs, CA 90670

Telephone: (562) 464-9901, (714) 547-9218

Fax: (714) 547-1969

connertoncooking.com

CN-SM-36 Salamander Broiler

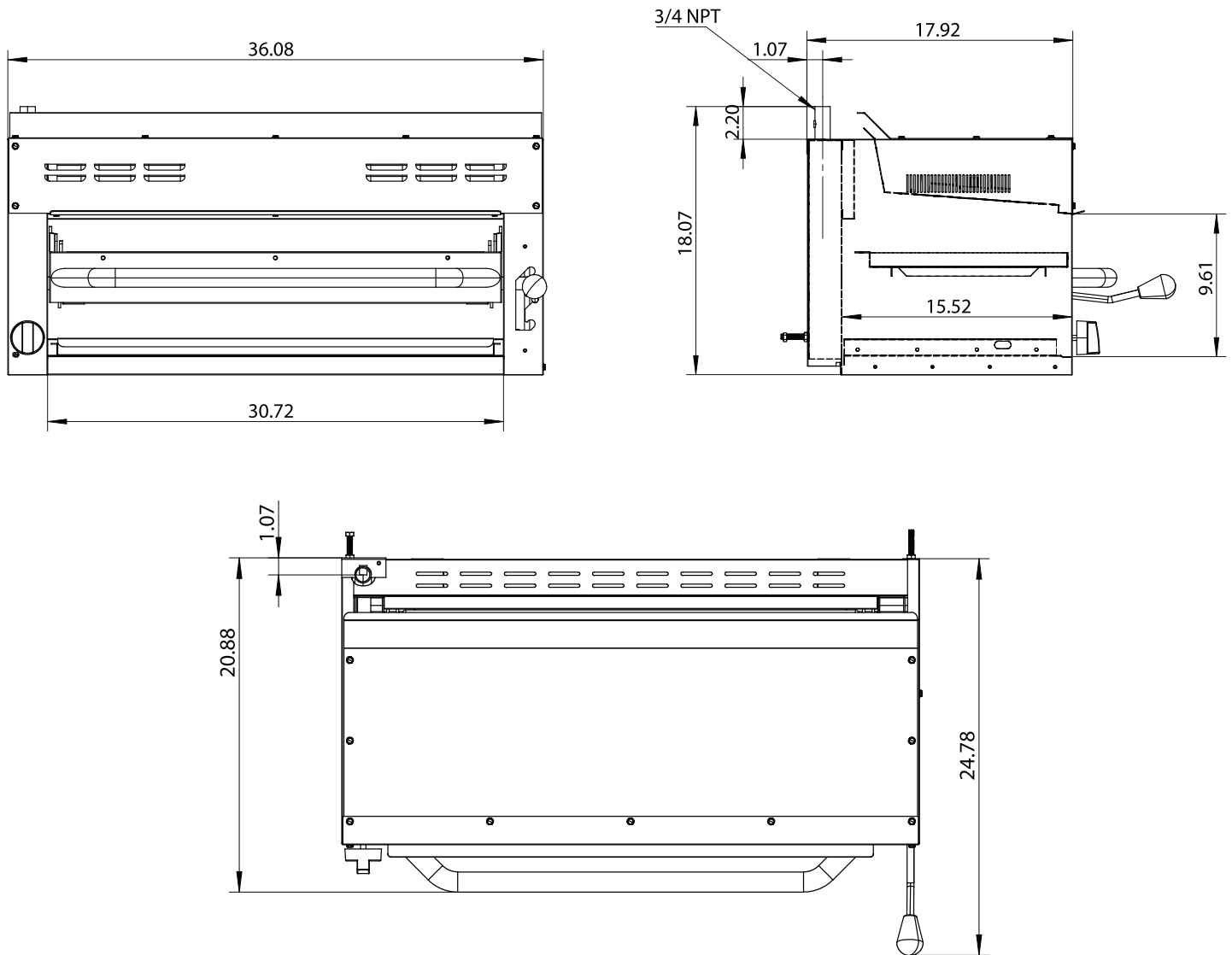

Models	Gas type	Intake-tube Pressure (in.W.C.)	Total BTU B.T.U./h	Regulator	Exterior dimensions (inch)	Net weight (lbs)	Gross weight (lbs)
CN-SM-36	NG	5	35,000	5" w.c.	36×18×18	92	115
	LP	10	32,000	10" w.c.			