

# STAND MOUNTED, DIRECT STEAM

6, 12 OR 20 GAL. TILTING, 2/3 STEAM JACKETED (1 OR 2 EACH)  
 18" HIGH STAND WITH DRAIN  
 450, 650, 1050, 1200 OR 1600MM WIDTHS

Project \_\_\_\_\_  
 Item \_\_\_\_\_  
 Quantity \_\_\_\_\_  
 FCSI Section 11400 \_\_\_\_\_  
 Approved \_\_\_\_\_  
 Date \_\_\_\_\_

## Models

- SD-450-K6
- SD-650-K12
- SD-1050-K20
- SD-1050-K66
- SD-1200-K612
- SD-1600-K1212
- SD-1800-2020



## Standard Features

- Type 304 Stainless Steel construction, with #4 finish on Kettle
- Factory Assembled Kettle/Stand combinations with available kettle capacities to suit most needs
- Steam Control Kit: includes: Needle Type Steam Control Valve, Steam Trap, Condensate Strainer, Check Valve, Nipples and Fittings, factory assembled and mounted on kettles(s)
- Kettles are Mounted on Stainless Steel Stand of Modular Cabinetized Design
- Hot and Cold Water Faucet with Swing Spout
- Table Top has Full Width Drain Trough equipped with standing 1.50" diameter male Drain Connection
- Sliding drain Catch Pan with Splash Shield, easy to position for use
- Kettles are 2/3 Steam Jacketed and include Lift-Off Covers
- 50 psi Steam Jacket Rating
- 50 psi Chrome Plated Safety Valve
- Manual Tilting, Balanced Design
- Typical approvals include NSF and ASME

## Short Form Specifications

Shall be CLEVELAND, Kettle(s) with Stand, Model SD - \_\_\_\_\_ - K \_\_\_\_\_, full width Drain Trough with 1 1/2" male Drain Connection, Sliding Catch Pan and 2/3 Steam Jacketed Kettle(s) \_\_\_\_\_ ea. \_\_\_\_\_ Gallon (and \_\_\_\_\_ ea. \_\_\_\_\_ Gallon) Steam Jacket Ratings to be 50 psi; Kettle and Legs to be Type 304 Stainless Steel. To operate, connect directly to a steam source supplying from 5 to 45 psi steam. Steam Condensate Trap and Strainer, Factory Assembled and Installed; includes: Hot and Cold Water Faucet with Swing Spout and Lift-Off Kettle Covers.

## Options & Accessories

- Type 316 Stainless Steel Kettle Interior for high acid food products (316)
- Cooking Basket (BS)
- Food Strainer (FS)
- Steam Pressure Reducing Valve, where supply exceeds 45 psi (PRV)
- Steam Supply Moisture Separator/Trap (MS)
- Single Pantry Faucet (SPK)
- Wall Meter, wall mount (GM For MLMF)
- Water Cooling, wall mount
- Back Wall or Back Splash (BW-32 or BS-4)
- Self Locking Hand Tilt Mechanism (HTK - 12 gallons only)

SERVICE CONNECTIONS DIAGRAM

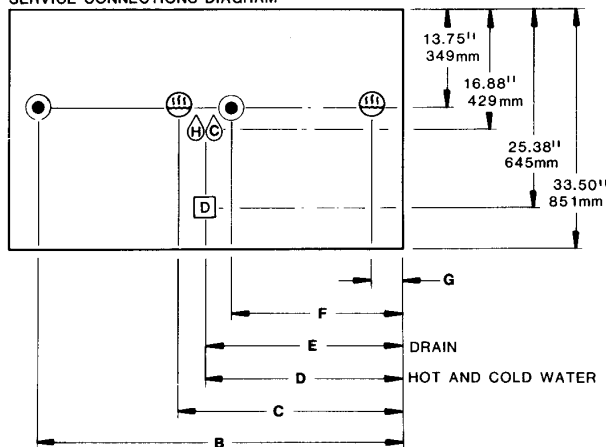

CAPACITIES: (in 4 oz. servings, other sizes may be calculated.)  
 6 Gallon / 23 liters . . . 160 per kettle  
 12 Gallon / 45 liters . . . 352 per kettle  
 20 Gallon / 80 liters . . . 704 per kettle

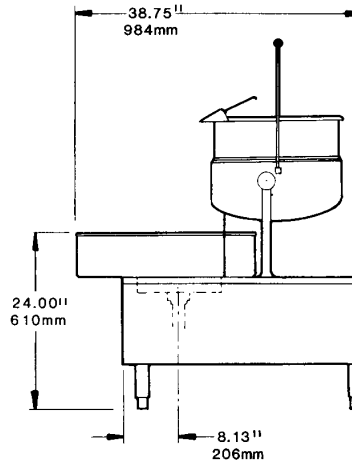
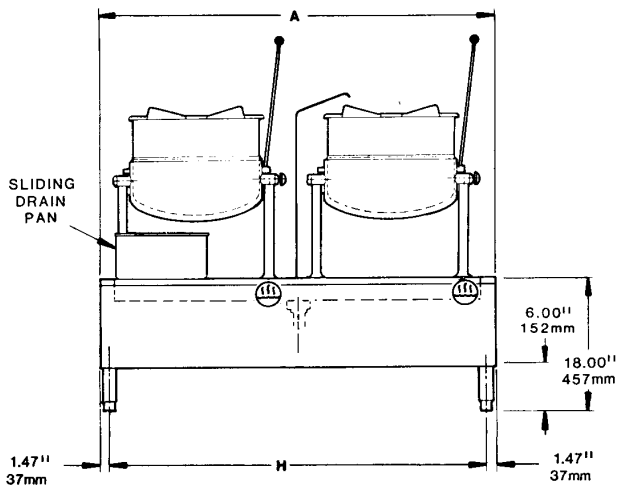

MODEL		A	B	C	D	E	F	G	H
SD- 450-K6	IN	17.72	—	—	—	8.86	15.97	3.97	14.78
	mm	450	—	—	—	225	406	101	375
SD- 650-K12	IN	25.59	—	—	—	12.80	23.84	4.34	22.65
	mm	650	—	—	—	325	606	110	575
SD-1050-K20	IN	41.34	—	—	5.50	20.67	23.75	4.50	38.40
	mm	1050	—	—	140	525	603	114	975
SD-1050-K66	IN	41.34	37.09	25.09	20.67	20.67	16.25	4.25	38.40
	mm	1050	942	637	525	525	413	108	975
SD-1200-K612	IN	47.24	43.50	31.50	27.75	23.62	24.00	4.25	44.30
	mm	1200	1105	800	705	600	610	108	1125
SD-1600-K1212	IN	62.99	55.50	36.00	31.50	31.50	27.00	7.50	60.05
	mm	1600	1410	914	800	800	686	191	1525
SD-1800-K2020	IN	62.99	59.50	35.75	32.00	31.50	28.25	4.50	60.05
	mm	1600	1511	908	813	800	718	114	1525

Shipping Weights & Dimensions  
 Model -  
 SD450K6 Weight - 145 lbs  
 SD650K12 Weight - 240 lbs  
 SD1050K66 Weight - 302 lbs  
 Width - 45"  
 Depth - 44"  
 Height - 55"

DIRECT STEAM	WATER	DRAIN	CLEARANCE
Steam Inlet: 1/2" IPS minimum line Total Kettle capacity: 20 gallons or less = 1/2" 25 gallons or more = 3/4" Operating Pressure: 5 to 45 psi with a 50 psi Safety Valve CONDENSATE RETURN 1/2" N.P.T.	3/4" O.D. copper tube or 1/2" NPT pipe	1 1/2" diameter American Standard straight pipe thread LF.	RIGHT = 0 LEFT = 0 REAR = 0

## NOTES:

Cleveland Range reserves right of design improvement or modification, as warranted.  
 Many regional, state and local codes exist and it is the responsibility of the owner and installer to comply with the codes.  
 Installation of backflow preventers, vacuum breakers and other specific code requirements is the responsibility of the owner and installer.  
 Cleveland Range equipment is built to comply with applicable standards for manufacturers. Included among those approval agencies are U.L., A.G.A., NSF, ASME/N.Bd., CSA, CGA, ETL and others. (NOT TO SCALE)