

# MIXER KETTLES, GAS-FIRED HORIZONTAL AGITATOR 2/3 STEAM JACKETED, TILTING

Project \_\_\_\_\_  
 Item \_\_\_\_\_  
 Quantity \_\_\_\_\_  
 FCSI Section 11400 \_\_\_\_\_  
 Approved \_\_\_\_\_  
 Date \_\_\_\_\_

## Models

- HA-MKGL-60-T    • HA-MKGL-100-T
- HA-MKGL-80-T



## Standard Features

- 60, 80 or 100 gallon working capacity
- Type 304 stainless steel with #4 finish on kettle and supports
- Precise solid state temperature control
- Solid state low water safety controls in a plug-in module
- L.E.D. indicators for heat cycle and low water warning
- 3" dia. butterfly valve
- Three (3) horse power horizontal agitator drive
- Variable mixer speed control from 5 to 20 r.p.m. with agitator start/stop controls
- Spring loaded teflon blades scrape the entire heated surface area
- Internal mixing fins for most efficient, uniform mixing of products
- Easily removable agitator without the use of tools
- 190 M-BTU high efficiency power burner heating system for fast heat-up and recovery times
- "Glow type" automatic safety ignition system
- Power tilt mechanism with case hardened self-locking worm and segment gear
- Kettle steam jacket permanently filled with treated distilled water
- 50 psi steam jacket rating and safety valve
- Front mounted combination pressure-vacuum gauge
- Heavy duty welded rim bar
- Water fill faucet with swing spout for hot and cold water
- Faucet mounting bracket.
- Spring assisted, hinged stainless steel cover
- Standard for Natural Gas operation
- Standard Electrical for agitator drive is 208V/3Ph/60Hz
- Accepted for use in USDA inspected facilities
- Typical approvals include AGA, CSA, CE, NSF and ASME

## Short Form Specifications

Shall be Cleveland Model HA-MKGL- \_\_\_\_ -T, gas fired, 2/3 steam jacketed, \_\_\_\_ gallon operating capacity, tilting horizontal agitator mixer kettle. 190M BTU High Efficiency Power Burner heating system with automatic Glow Type Ignition, type 304 stainless steel with #4 finish on kettle and supports, insulated Heat Exchanger, 50 psi jacket rating, 3HP Motor Drive for mixer arm with variable speed control, variable temperatures control, L.E.D. indicators for heat cycle and low water warning, 3" dia. Butterfly Valve.

## Options & Accessories

- Type 316 stainless steel kettle liner for high acid products (316)
- Dolly for horizontal agitator
- Stainless steel bi-fold hinged cover
- 3" diameter air operated flush mounted piston draw-off valve with variable control (FPVA3, for use with a food pump, replaces 3" butterfly valve, requires air compressor)
- Automatic water meter (GMF or LMF) Wall or stand mounted)
- Food Strainer (FS)
- Kettle Accessory Kit (KAK) includes:
  - Clean-up Brush (CB)
  - 36" Kettle Paddle (KP)
  - 36" Kettle Whip (KW)
  - 36" Kettle Brush (KB)
  - Draw-off Brush (DB)
  - 24 oz. Ladle (KL)
- Option for propane gas operation (PG)
- Voltage option for agitator drive other than standard 208V/3Ph/60Hz

KE004046-48

<b>ELECTRICAL SUPPLY</b>	<b>GAS SUPPLY (PIPING 3/4" NPT)</b>	<b>AIR SUPPLY (PIPING 1/2" NPT)</b>	<b>APPROX. SHIPPING WEIGHTS</b>
<b>VOLTS:</b> 208/240 <b>PHASE:</b> 3 <b>AMPS:</b> 15 <b>FREQ:</b> 60 HZ	<b>TYPE:</b> NAT or LP <b>BTU PER CU. FT.:</b> 1000 (NAT), 2500 (LP) <b>SUPPLY PRESSURE:</b> 4" to 14" W.C.	<b>PRESSURE:</b> 90 - 100 PSI (only required for optional 3" dia. piston draw-off valve)	
<b>APPROVALS</b>		<b>HOT &amp; COLD WATER</b>	<b>60 GAL -</b> 1010 LBS. 458 KG. <b>80 GAL -</b> 1120 LBS. 508 KG. <b>100 GAL -</b> 1325 LBS. 601 KG.
<b>AGA</b> ✓	<b>CGA</b> ✓	<b>NSF</b> ✓	
<b>BTU RATINGS:</b> 190,000 per hour		<b>CLEARANCE</b> RIGHT: 3", LEFT: 3" REAR: 3" (ALLOW 12" SPACE MINIMUM ON LEFT SIDE FOR SERVICE)	

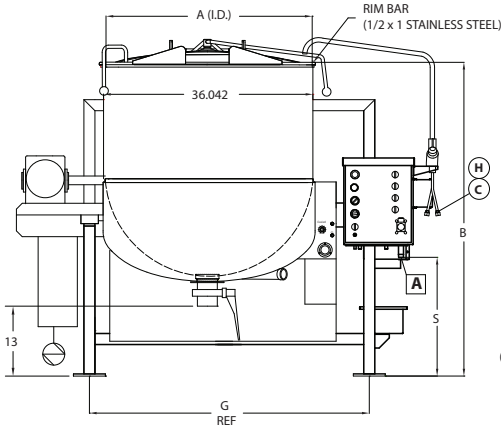
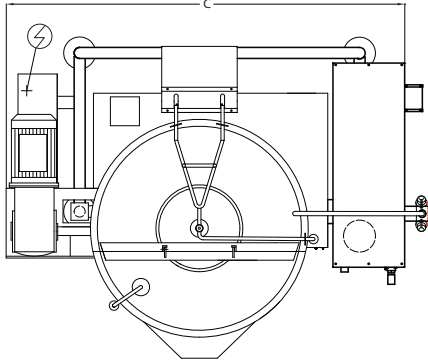
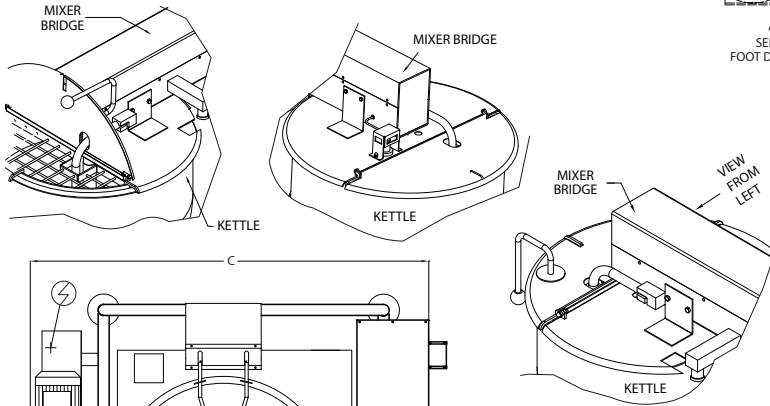
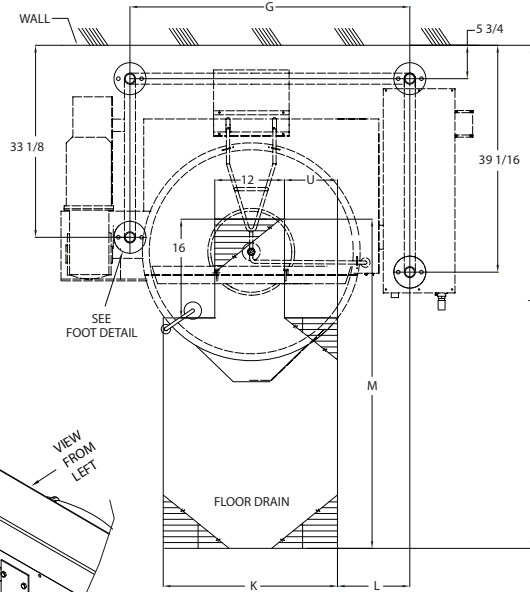

KETTLE WITH REGULAR FAUCET & BUTTERFLY VALVE (BV-3)

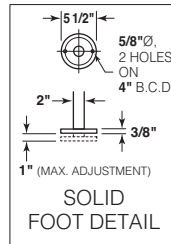

4 INCH MINIMUM  
6 INCH RECOMMENDED  
(SEE ALSO FLOOR DRAIN &  
FEET LOCATION DET.)

PIPE DRAIN RECOMMENDED  
MINIMUM VALVE SIZE PLUS 1"

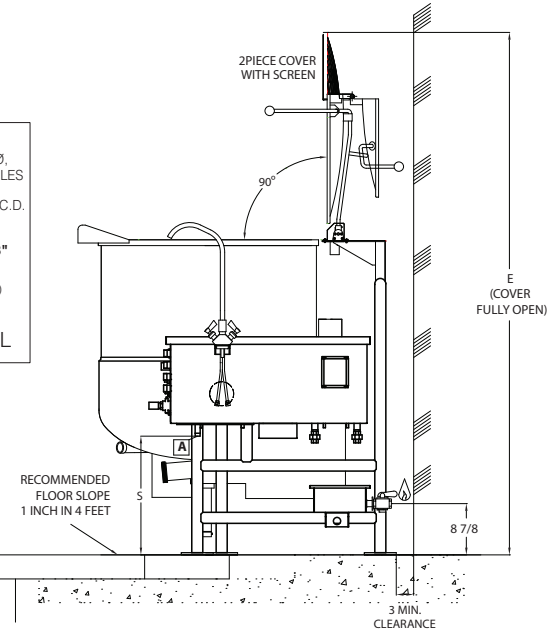

FLOOR DRAIN & FEET LOCATION DET.

**DIMENSIONS**

MODEL	A	B	C	D	E	G	J	K	L	M	N	P	S	U
HA-MKGL-60-T	29 1/2"	50 1/4"	62 5/8"	52 1/4"	93 1/2"	42"	78 5/8"	28"	10 3/8"	53"	65 3/8"	69 1/2"	21 1/4"	8"
HA-MKGL-80-T	33"	51 3/4"	66 1/8"	52 3/4"	96 1/2"	45 11/16"	84 5/8"	30"	11 7/16"	57"	68 7/8"	69"	20 1/2"	9"
HA-MKGL-100-T	35 1/2"	54 1/4"	68 5/8"	55 1/4"	102 1/2"	48 3/16"	96 1/4"	32"	11 5/8"	66"	71 3/8"	71 1/2"	22"	10"

**NOTES:**

Cleveland Range equipment is built to comply with applicable standards for manufacturers. Included among those approval agencies are: UL, A.G.A., NSF, ASME/N.B.D., CSA, CGA, ETL, and others. Installations of back flow preventers, vacuum breakers and other specific code requirements are the responsibility of the owner and installer. All vertical dimensions shown are minimum. Feet are adjustable to +1" maximum. Manufacturer must be notified if unit will be operating above 2000' altitude. Consult factory for manufactured gas. Cleveland Range reserves the right of design improvement or modification, as warranted.

(NOT TO SCALE)

Mixer Kettles