

Belshaw's H & I ("Heat and Ice") Bowl Icers are designed and constructed for convenience, durability and reliability, even after years of use in tough operating conditions. The H & I method provides gentle, uniformly applied heat to the bottom portion of each icing bowl from a large tank full of warmed water. The use of warm water heat allows icing to remain in condition for long periods.

- H&I-2 is a two-bowl icer
- H&I-4 is a four bowl icer, allowing more flexibility in switching between four or more icing flavors

STANDARD FEATURES

- Stainless steel construction
- 13" (33cm) diameter stainless steel bowls with aluminum lids
- Each bowl holds approximately 7 lbs (equivalent to 8 quarts) of icing (3.2 kg, 7.6 liter)
- Large water tank
- H&I-2: water capacity approximately 15 Gallons (57 Liters)
- H&I-4: water capacity approximately 28.5 Gallons (108 Liters)
- Water heat controlled by thermostat (maximum temperature approximately 130°F (55°C))
- 4 heavy duty caster wheels (2 lockable)
- Manual thermometer
- Drain and valve for emptying water
- ETL, NSF listed

CERTIFICATIONS

- Certified to UL-197, NSF-4
- CE models available for European Union and other countries

ACCESSORIES

- Extra bowls and lids are available.



H&I-2 Bowl Icer



H&I-4 Bowl Icer

FRONT VIEW
H&I-2 and

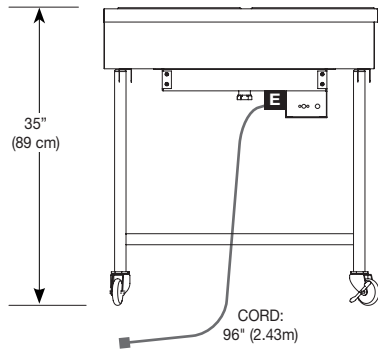

TOP VIEW
H&I-2
Two Bowls

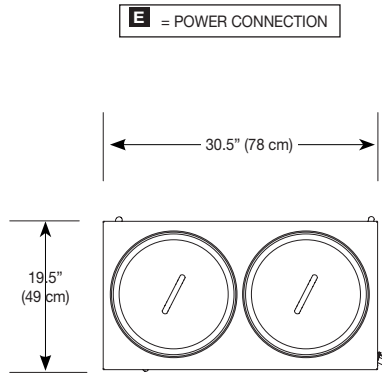

TOP VIEW
H&I-4
Four Bowls

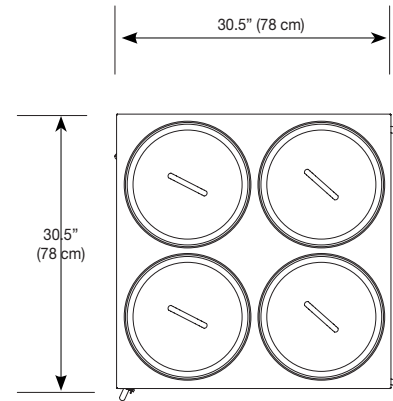

ELECTRICAL DATA

Specify voltage at time of order. Data applies to both H&I-2 and H&I-4

120V, 50/60hz, 1 ph	amps	15 A
	kilowatts	1.8 KW
240V, 50/60hz, 1 ph	amps	7.5 A
	kilowatts	1.8 KW
PLUG	120V	NEMA 5-15P
	240V N.America	NEMA 6-15P
	240V International	Not supplied
CORD	length	96 inches (2.5 m)

SHIPPING DIMENSIONS

(Approximate, shipped in carton or on pallet)

		H&I-2	H&I-4
SHIPPING DIMENSIONS <i>(Approximate, shipped in carton on pallet or crate)</i>	inches	31" x 20" x 37"	31" x 31" x 37"
	cm	79 x 51 x 94 cm	79 x 79 x 94 cm
	lbs	80 lbs	91 lbs
	kg	37 kg	42 kg
FREIGHT CLASS		100	100