

500-2DI Drawer Warmers

UL



Designed for both durability and exceptional food quality, Alto-Shaam's warming drawers seamlessly integrate into any kitchen layout where hot and fresh, ready-to-serve food needs to stay within easy reach. Featuring Halo Heat® technology, these drawers hold food at optimal serving temperatures without added water or harsh heating elements—preserving taste, texture, and freshness. Choose from flexible configurations: install in cabinets or counters, or stack units to make the most of your space.

Alto-Shaam's warming drawers feature a durable, non-magnetic, stainless steel exterior and removable stainless steel drawer rail supports. Each drawer includes one (1) full-size hotel [GN 1/1] stainless steel pan—6 inches [152mm] deep. The unit is operated via an ON/OFF power switch and up and down arrow buttons on a digital display. It also includes a heat indicator light and a temperature display button.



Standard features

- Halo Heat...a controlled, uniform heat source that gently surrounds foods for better appearance, taste, and longer holding life.
- Product moisture is retained without adding water.
- Dual digital controls—one per drawer—sense temperature drops faster, providing quick heat recovery time.
- Can be built into cabinets or counters. Built-in trim kits are available.
- Stackable design.
- Vented for optimal moisture control.



TEMPERATURE

Temperature range: 60°F to 200°F [16°C to 93°C]



CAPACITY

Size	Pan Quantity	Product Weight per Drawer lb (kg)
500-2DI	Two (2) Full-size hotel [GN 1/1]; or Two (2) oversize 15"x20"x6"	36 [16] 41 [19]



ELECTRIC

Power Options and Cord/Plug Assemblies

NOTE: All cord/plug assemblies are 6' [1.82M] long.

120V

- 120V/60 Hz/1 Ph, NEMA 5-15P [5038469]

208V-240V

- 208V-240V/60 Hz/1 Ph, NEMA 6-15P [5038470]



500-2DI Drawer Warmers



DIMENSIONS

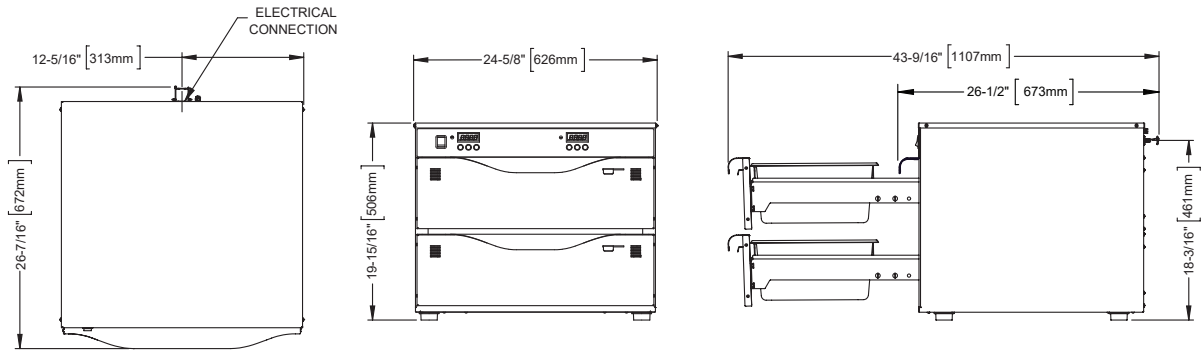

Shown with feet

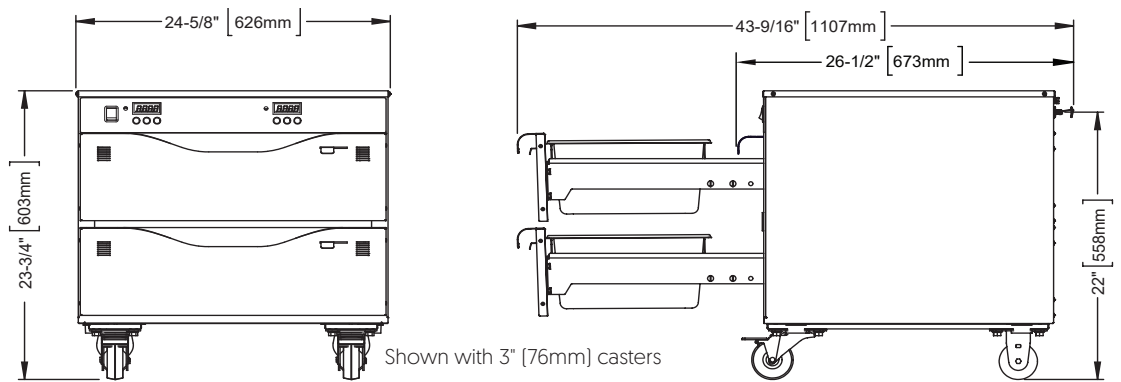

Shown with 3" [76mm] casters

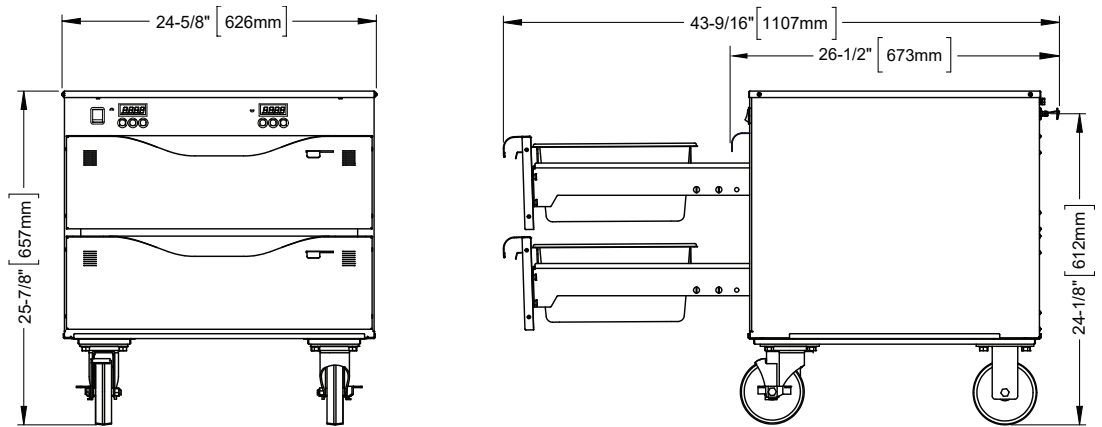

Shown with 5" [127mm] casters

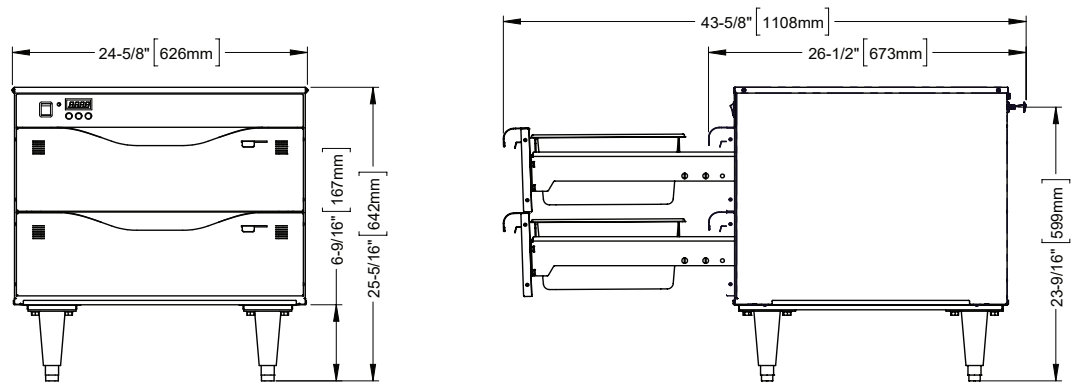

Shown with 6" [152mm] legs

500-2DI Drawer Warmers



DIMENSIONS

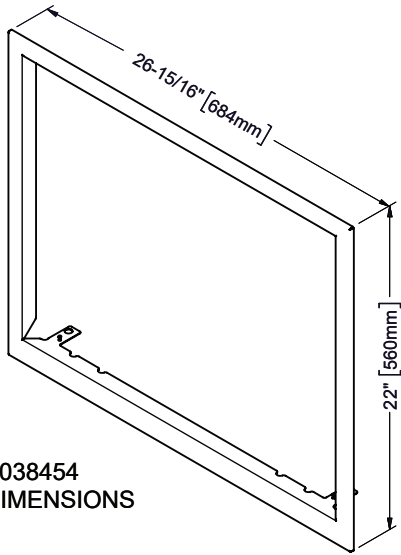

500-2DI 5038454
TRIM KIT DIMENSIONS

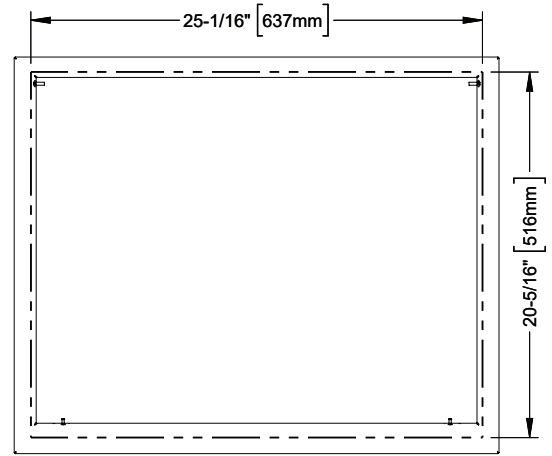

CUT-OUT DIMENSIONS



CLEARANCE

Top: 2" [51mm]
 Left: 1" [25mm]
 Right: 1" [25mm]
 Back: 3" [76mm]



REQUIREMENTS

- Drawer warmer must be installed level.
- Drawer warmer must not be installed in any area where it may be affected by steam, grease, dripping water, extreme temperatures, or any other severely adverse conditions.



HEAT

Heat of rejection

	Heat Gain qs, BTU/hr	Heat Gain qs, kW
500-2DI	262	0.08

Options and Accessories

- Perforated pan grid, 15" x 20" [381mm x 508mm] [1231]
- Perforated pan grid, 12" x 20" [305mm x 508mm] [16642]

Extended warranty

- One-year warranty extension



WEIGHTS

Size	Net Weight (est.)	Shipping Weight (est.)	Carton Dimensions (L x W x H)
500-2DI	115 lb [52 kg]	125 lb [57 kg]	30" x 27" x 23" [762mm x 686mm x 584mm]



ELECTRIC

500-D/DN/DI	V	Ph	Hz	A	Breaker (A)	kW
120V	120	1	60	16	20	1.9
208-240V	208	1	50/60	11	15 UL 20 CSA	2.3
	240	1	50/60	13	15 UL 20 CSA	3.0

Electrical connections must meet all applicable federal, state, and local codes.

CONTACT US

W164 N9221 Water Street | Menomonee Falls, Wisconsin 53051 | U.S.A.
 Phone: 262.251.3800 | 800.558.8744 U.S.A./Canada | Fax: 262.251.7067 | alto-shaam.com