

ALTO-SHAAM®

Hot Food Holding Cabinets Electric

COMBI MATE
W A R M E R



20-20MW

Models:

20-20W

20-20MW

Alto-Shaam_5020829_1

- **Installation**
- **Operation**
- **Maintenance**

W164 N9221 Water Street • P.O. Box 450
Menomonee Falls, Wisconsin 53052-0450 U.S.A.

PHONE: 262.251.3800 • 800.558.8744 U.S.A. / CANADA
FAX: 262.251.7067 • 800.329.8744 U.S.A. ONLY
www.alto-shaam.com



Consult instructions
for operation and use.



Table of Contents

Warranty and Service Information	3
Delivery	4
Transportation Damage Claims	5
Unpacking	6
Safety Procedures	7
Installation	9
Dimensions	10
Electrical Connection	12
Operation	13
General Holding Guidelines	15
Cleaning and Preventative Maintenance	16
Food Safety	18
Troubleshooting	19
Service	21
Limited Warranty	back cover

Extend Your Manufacturer's Warranty

Register

Register your Alto-Shaam appliance online, and you will automatically be entered into a monthly drawing to win an additional year extended warranty! Registering your appliance ensures prompt service in the event of a warranty claim. You will also receive direct notifications of software updates and additional product information.

Your personal information will not be shared with any other company.

www.alto-shaam.com/warranty

Alto-Shaam 24/7 Emergency Repair Service

Call

Call 800-558-8744 to reach our 24-hour emergency service call center for immediate access to local authorized service agencies outside standard business hours. The emergency service access is provided exclusively for Alto-Shaam equipment and is available throughout the United States through Alto-Shaam's toll free number.

Availability

Emergency service access is available seven days a week, including holidays.

Delivery

This Alto-Shaam appliance has been thoroughly tested and inspected to ensure only the highest quality appliance is provided. Upon receipt, check for any possible shipping damage and report it at once to the delivering carrier. See Transportation Damage and Claims section located in this manual.

This appliance, including unattached items and accessories, may be delivered in one or more packages. Ensure all standard items and options have been received with each appliance as ordered. Save all the information packed with the appliance. Register the appliance online at www.alto-shaam.com/en/support/warranty-registration to ensure prompt service in the event of a warranty parts and labor claim.

This manual must be read and understood by all people using or installing the appliance. Contact the Alto-Shaam Tech Team Service Department if you have any questions concerning installation, operation, or maintenance.

1-800-558-8744; servicedept@alto-shaam.com

The serial number is required for all inquiries.

Always include both model and serial number(s) in any correspondence regarding the appliance.

Model: _____

Serial number: _____

Purchased from: _____

Date installed: _____ **Voltage:** _____

CAUTION



Appliance and accessories may be heavy. To prevent serious injury, **always** use a sufficient number of trained and experienced workers when moving or leveling appliance and handling accessories.

Environmental Conditions

Operational Environmental Conditions

- Before use, appliance must acclimate to room temperature in the environment it is placed – 24 hours is recommended.
- Ambient temperature range of 60°F to 110°F (16°C to 43°C).
- Relative humidity of less than 95% non-condensation.
- Atmospheric pressure range of 50kPa to 106kPa.

Transportation Damage Claims



All Alto-Shaam equipment is sold Free on Board (F.O.B.) shipping point, and when accepted by the carrier, such shipments become the property of the consignee.

Should damage occur in shipment, do not put the appliance into service until the damage has been inspected by an authorized Alto-Shaam service provider.

Shipping damages are a matter between the carrier and the consignee. In such cases, the carrier is assumed to be responsible for the safe delivery of the merchandise, unless negligence can be established on the part of the shipper.

1. Make an immediate inspection while the appliance is still in the truck or immediately after it is moved to the receiving area. Do not wait until after the appliance is moved to a storage area.
2. Do not sign a delivery receipt or a freight bill until a proper count has been made and inspection of all appliances are received.

3. Note all damage to packages directly on the carrier's delivery receipt.
4. Make certain the driver signs the delivery receipt. If the driver refuses to sign, make a notation of this refusal on the receipt.
5. If the driver refuses to allow inspection, write the following on the delivery receipt: **Driver refuses to allow inspection of containers for visible damage.**
6. Contact the carrier's office immediately upon finding damage, and request an inspection. Mail a written confirmation to the carrier's office with the time, date, and the person called.
7. Save any packages and packing material for further inspection by the carrier.
8. Promptly file a written claim with the carrier and attach copies of all supporting paperwork.

Alto-Shaam will continue our policy of assisting our customers in collecting claims which have been properly filed and actively pursued. Alto-Shaam cannot, however, file any damage claims, assume the responsibility of any claims, or accept deductions in payment for such claims.

Record the model and serial number of the appliance for easy reference. Always refer to both model and serial number in any contact with Alto-Shaam regarding this appliance.

Model: _____

Serial Number: _____

Date Installed: _____

Voltage: _____

Purchased From: _____



Alto-Shaam has established a twenty-four hour emergency service call center to offer immediate customer access to a local authorized service agency outside of standard business hours. The emergency service access is provided exclusively for Alto-Shaam equipment and is available throughout the United States through the use of Alto-Shaam's toll-free number. Emergency service access is available seven days a week including holidays.

Unpacking

- Carefully remove the appliance from the carton or crate.

NOTE: Do not discard the carton and other packaging material until you have inspected the appliance for hidden damage and tested it for proper operation.

Do not discard this manual. This manual is considered to be part of the appliance and is to be provided to the owner or manager of the business or to the person responsible for training operators. Additional manuals are available from the manufacturer.

- Read all instructions in this manual carefully before installing this appliance, using the appliance or performing routine maintenance. Following procedures other than those indicated in this guide to use and clean the appliance is considered inappropriate and may cause damage, injury or fatal accidents, in addition to voiding the warranty and relieving Alto-Shaam of all liability.
- Remove all protective plastic film, packaging materials, and accessories from the appliance before connecting electrical power. Store any accessories in a convenient place for future use.

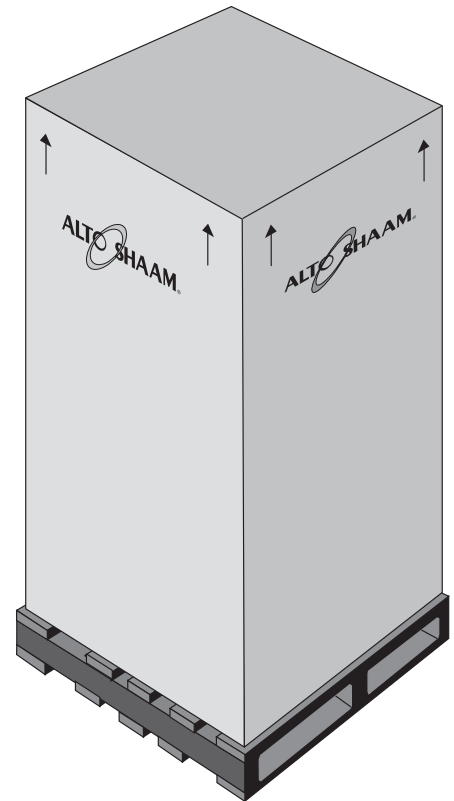

- The appliance is intended to cook, hold or process foods for the purpose of human consumption. No other use for this appliance is authorized and is therefore considered dangerous. The appliance must not be used to cook food containing flammable materials (such as food with alcohol). Substances with a low flash point can ignite spontaneously and cause a fire.
- The appliance is intended for use in commercial establishments where all operators are familiar with the purpose, limitations, and associated hazards of this appliance. Operating instructions and warnings must be read and understood by all operators and users. Alto-Shaam recommends regular staff training to avoid the risk of accident or damage to the appliance. Operators must also receive regular safety instructions.
- Any troubleshooting guides, component views, and parts lists included in this manual are for general reference only and are intended for use by qualified and trained technicians.
- This manual should be considered a permanent part of this appliance. This manual and all supplied instructions, diagrams, schematics, parts lists, notices, and labels must remain with the appliance if the item is sold or moved to another location.

Knowledge of proper procedures is essential to the safe operation of electrically and/or gas energized equipment. The following signal words and symbols may be used throughout this manual.

DANGER

Indicates a hazardous situation that, if not avoided, will result in death or serious injury.

WARNING

Indicates a hazardous situation that, if not avoided, could result in death or serious injury.

CAUTION

Indicates a hazardous situation that, if not avoided, could result in minor or moderate injury.

NOTICE: Indicates information considered important, but not hazard-related (e.g., messages relating to property damage).



Indicates that referral to operating instructions is recommended to understand operation of equipment.

NOTICE: For equipment delivered for use in any location regulated by the following directive: 2012/95/EC WEEE



Do not dispose of electrical or electronic equipment with other municipal waste.

Safety Procedures

- To prevent serious injury, death or property damage, the appliance should be inspected and serviced at least every twelve (12) months by an authorized service partner or trained technician.
- **Only** allow an authorized service partner or trained technician to service or to repair the appliance. Installation or repairs that are not performed by an authorized service partner or trained technician, or the use of non-factory authorized parts will void the warranty and relieve Alto-Shaam of all liability.
- When working on this appliance, observe precautions in the literature, on tags, on labels attached to or shipped with the appliance and other safety precautions that may apply.
- If the appliance is installed on casters, freedom of movement of the appliance must be restricted so that utility connections (including gas, water, and electricity) cannot be damaged when the appliance is moved. If the appliance is moved, ensure that all utility connections are properly disconnected. If the appliance is returned to its original position, ensure that retention devices and utility connections are properly connected.
- **Only** use the appliance when it is stationary. Mobile appliance racks, mobile plate racks, transport trolleys, and appliances on casters can tip over when being moved over an uneven floor or threshold and cause serious injury.
- **Always** apply caster brakes on mobile appliances or accessories when these are not being moved. These items could move or roll on uneven floors and cause property damage or serious injury.
- Be extremely careful when moving appliances because the food trays may contain hot fluids that may spill, causing serious injury.
- **Always** open the appliance door very slowly. Escaping hot vapors or steam can cause serious injury.

WARNING



To prevent **serious personal injury, death, or property damage:**

The appliance must be cleaned thoroughly to avoid deposits of grease and or food residue inside the appliance that may catch fire. If fat deposits and/or food waste inside the appliance ignite, shut down the appliance immediately and keep the appliance door closed to extinguish the fire. If further extinguishing is required, disconnect the appliance from the main power and call the fire department. Failure to clean the appliance properly voids the warranty and relieves Alto-Shaam of all liability.

WARNING

This appliance is not intended for use by persons (including children) with reduced physical, sensory or mental capabilities, or lack of experience and knowledge, unless they have been given supervision concerning use of the appliance by person responsible for their safety.

Children should be supervised to ensure that they do not play with the appliance.

⚠ WARNING

Improper installation, alteration, adjustment, service, cleaning, or maintenance could result in property damage, severe injury, or death.

Read and understand the installation, operating and maintenance instructions thoroughly before installing, servicing, or operating this equipment.

⚠ CAUTION



To prevent **personal injury** or **property damage**:

Always use hand protection when operating this appliance to avoid burns. Metal parts of this equipment become extremely hot when in operation.

⚠ CAUTION



Appliance and accessories may be heavy. To prevent serious injury, **always** use a sufficient number of trained and experienced workers when moving or leveling appliance and handling accessories.

⚠ WARNING



To prevent personal injury, death or property damage:

Do not store or use gasoline or other flammable vapors or liquids in the vicinity of this or any other appliance.

1. This appliance, complete with unattached items and accessories, may be delivered in one or more packages. Check to ensure that all items ordered have been received.
2. This appliance is designed for the purpose of maintaining hot food at a temperature for safe consumption. The unit must be installed on a level surface in a location that will permit the equipment to function for its intended purpose and allow adequate access for proper cleaning and maintenance.
3. The appliance must not be installed in any area where it will be affected by steam, grease, dripping water, high temperatures, or any other severely adverse conditions.
4. Level the appliance from side-to-side and front-to-back with the use of a spirit level. 
5. In order to maintain standards established by the National Sanitation Foundation, floor models must be sealed at bottom by NSF approved sealant, or equipped with casters, or 6" (152mm) legs to provide minimum unobstructed space beneath the unit. Warranty will become null and void if these directions are not followed.

Clearance Requirements

Back	3" (76mm)
Top	2" (51mm)
Left side, Right side	1" (25mm)

Weight

Net	378 lb (171mm)
Ship	513 lb (233 kg)

Dimensions

Model 20-20MW - Mobile

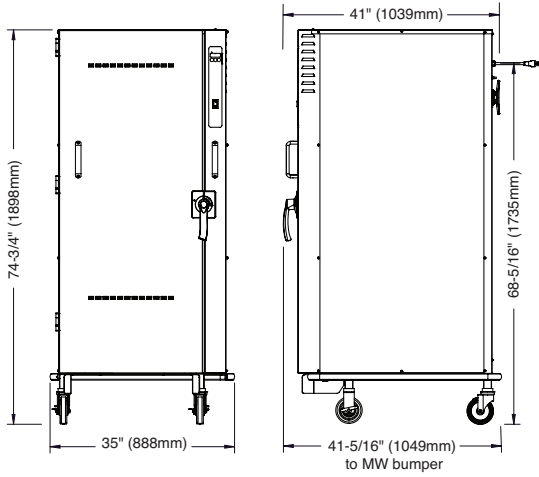
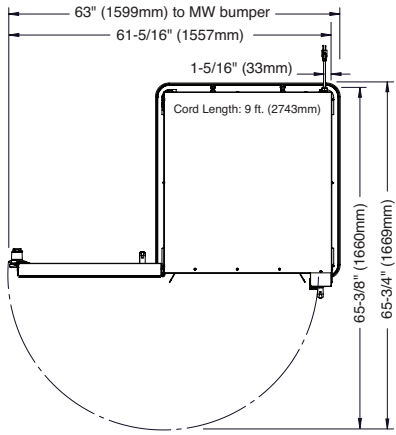

Model 20-20W - Stationary

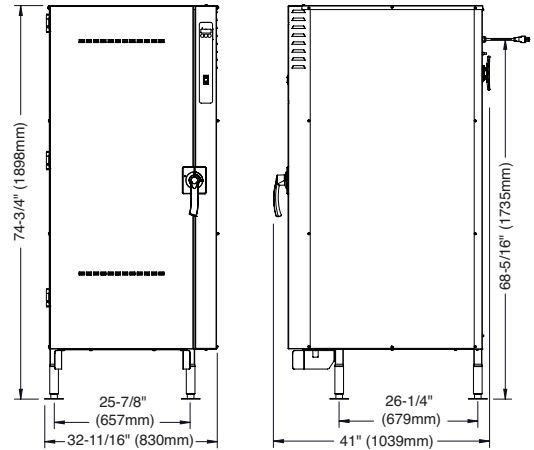
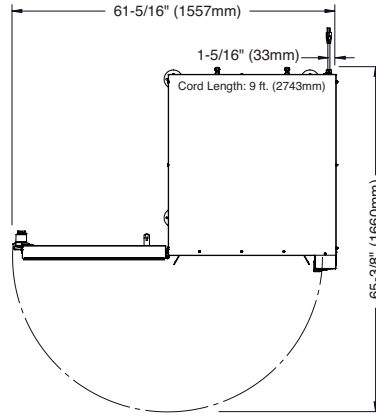

Optional Pan Cart

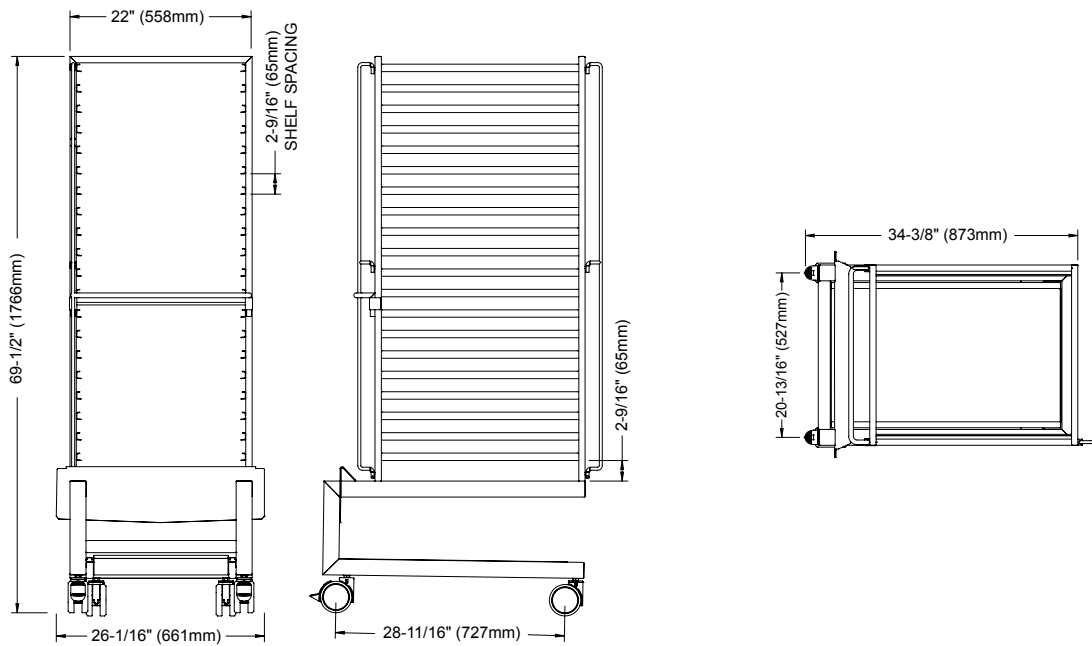

Accessories	
Preheat Sealing Strip	5016989
Roll-In Pan Carts (H x W x D)	
20 shelf pan trolley - Fits 20-20E, 20-20G, 20-20MW, and QC3-100 69-1/2" x 26-1/16" x 34-7/16" (1766 x 661 x 873mm) 2-9/16" (65mm) vertical spacing between shelves	5026385 5026431 (CI)
20 shelf pan trolley - Fits 20-10E, 20-10G, 20-20MW, and QC3-100 69-1/2" x 18" x 29-11/16" (1766 x 465 x 753mm) 2-9/16" (65mm) vertical spacing between shelves	5026388 5026434 (CI)
Roll-In Plate Carts (h x w x d)	
102 plate trolley - Fits 20-20E, 20-20G, 20-20MW, and QC3-100 69-5/8" x 26-7/8" x 42-1/2" (1769 x 683 x 1080mm) 3" (77mm) vertical spacing between shelves	5026387 5026433 (CI)
84 plate trolley - Fits 20-20E, 20-20G, 20-20MW, and QC3-100 69-5/8" x 26-7/8" x 42-1/2" (1769 x 683 x 1080mm) 3-11/16" (93mm) vertical spacing between shelves	5026386 5026432 (CI)
60 plate trolley - Fits 20-10E, 20-10G, 20-20MW, and QC3-100 69-13/16" x 18-3/4" x 37-1/8" (1773 x 475 x 943mm) 2-9/16" (66mm) vertical spacing between shelves	5026390 5026438 (CI)
51 plate trolley - Fits 20-10E, 20-10G, 20-20MW, and QC3-100 70" x 18-3/4" x 37-1/8" (1778 x 475 x 943mm) 3-1/16" (77mm) vertical spacing between shelves	5026389 5026435 (CI)
Shelf, Stainless Steel - 25-1/8" x 20-7/8" (638 x 529mm)	SH-22473

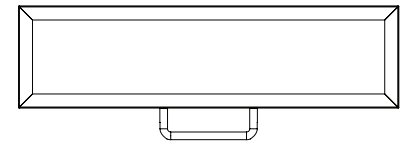

Preheat Sealing Strip

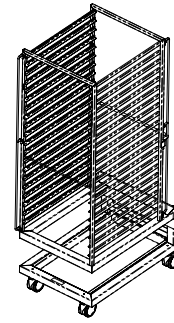

Optional Roll-In Pan Cart

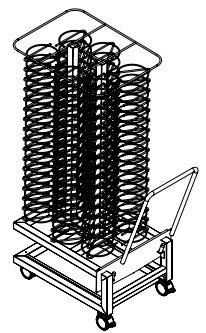

Optional Roll-In Plate Cart

CI - Correctional Institution

Roll-In Pan Cart Product\Pan Capacity	
480 lbs (218 kg) maximum	
Volume maximum: 300 quarts (284 liters)	
Full-Size Pans:	Forty (40) 20" x 12" x 2-1/2" maximum
	GN 1/1: Forty (40) (530mm x 325mm x 65mm)
	GN 2/1: Twenty (20) (650mm x 530mm x 65mm)
Full-Size Sheet Pans:	Ten (10) 18" x 26" x 1"
	Twenty (20) with added shelves

⚠ DANGER

To prevent serious injury, death, or property damage, **always** lock-out or post breaker panel until service work has been completed.

⚠ WARNING

To prevent serious injury, death, or property damage, **always** disconnect the appliance from the power source before cleaning or servicing.

Electrical Connection

WARNING



To prevent SERIOUS INJURY, DEATH or PROPERTY DAMAGE:

All electrical connections must be made by a qualified and trained service technician in accordance with applicable electrical codes.

1. An identification tag is permanently mounted on the cabinet.
2. Plug the unit into a properly grounded receptacle only. Arcing will occur when connecting or disconnecting the unit unless all controls are in the "Off" position.
3. Position the unit so the cord is easily accessible in case of any emergencies. If necessary, a proper receptacle or outlet configuration, as required for the unit, must be installed by a licensed electrician in accordance with applicable, local electrical codes.

NOTICE: Where local codes and CE regulatory requirements apply, appliances must be connected to an electrical circuit that is protected by an external GFCI outlet.

Hard wired models

Hard wired models must be equipped with a country certified external allpole disconnection switch with sufficient contact separation. Hard wired models that are mounted on casters must have a strain relief device (tether) to prevent strain on the power supply cord. If a power cord is used for the connection of the product an oil resistant cord like H05RN or H07RN or equivalent must be used.

! WARNING



To prevent serious injury, death, or property damage:

All electrical connections must be made by a qualified and trained service technician in accordance with applicable electrical codes.



This appliance must be adequately grounded in accordance with local electrical codes or, in the absence of local codes, with the current edition of the National Electrical Code ANSI/NFPA No. 70. In Canada, all electrical connections are to be made in accordance with CSA C22.1, Canadian Electrical Code Part 1 or local codes.



CE-approved appliances include an equipotential-bonding terminal marked with the symbol shown on the left. Provisions for earthing are to be made in accordance with IEC:2010 60335-1 section 27 or local codes.

! CAUTION



Power source must match voltage identified on appliance rating tag. The rating tag provides essential technical information required for any appliance installation, maintenance or repairs. Do not remove, damage or modify the rating tag.

Electrical							
V	Ph	Hz	A	kW			
208	1	50/60	10.8	2.2		NEMA 6-15P	
240	1	50/60	12.5	3.0		15A-250V Plug	
230	1	50/60	12.0	2.8		Plugs rated 250V	
	CEE 7/7		CH2-16P		BS 1363		AS/NZS 3112

Wire diagrams are located under the top cover of the appliance.

This appliance is intended for use in commercial establishments where all operators are familiar with the purpose, limitations, and associated hazards of this appliance. Operating instructions and warnings must be read and understood by all operators and users.

1. Ensure the unit is connected to the appropriate power source.
2. Use hand protection when handling hot items.
3. Preheat the appliance for 30 minutes before use.
4. Be certain only hot foods are placed into the appliance.
5. Do not operate this holding cabinet without the Roll-in Cart.

NOTICE

Do not operate this holding cabinet without its appropriate roll-in cart or preheat sealing strip.



CAUTION



To prevent **personal injury** or **property damage**:

Always use hand protection when operating this appliance to avoid burns. Metal parts of this equipment become extremely hot when in operation.



CAUTION

To prevent injury or property damage:
Always apply both caster brakes on mobile carts, appliances, or accessories when stationary. Appliances on casters can move or roll on uneven floors.

Heating Characteristics

The cabinet is equipped with a special, low-heat-density heating cable. Through the Halo Heat® concept, the heating cable is mounted against the walls of the warming compartment to provide an evenly applied heat source controlled by a thermostat. The design and operational characteristics of the cabinet eliminate the need for a moisture pan or a heat circulating fan. Through even heat application, the quality of a food product is maintained up to as much as several hours.

The primary purpose of the Model 20-20 Holding Cabinet is to operate as a functional extension of the Combitherm® Combination Oven/ Steamer. The combination oven is for high volume production – the Halo Heat companion holding cabinet preserves the quality and extends the longest possible holding life. The Roll-In Cart for the 20-20 are completely interchangeable between the Combitherm Oven and the Halo Heat Companion Holding Cabinet, along with compatible Alto-Shaam Quickchillers™.

The Combitherm Combination Oven/Steamer, along with the Halo Heat companion holding cabinet and Alto-Shaam Quickchiller give the food service operator the advantage of advance full-load preparation, better work-load scheduling, and the ability to hold the product for prolonged periods without major deterioration.

Before Initial Use:

Before operating the unit, clean both the interior and exterior with a clean, damp cloth and mild soap solution. Rinse carefully with a sponge and clean water. Clean and install the Roll-in Cart.

WARNING



To prevent **SERIOUS PERSONAL INJURY** or **PROPERTY DAMAGE**:

DO NOT handle pans containing liquid or semiliquid products positioned above the eye level of the operator. Such products may scald and cause serious injury.

Operation

1. Preheat at 200°F (93°C) for 30 minutes before loading food.

Push power switch to On position. The appliance will begin operating at the previous Set temperature.

- Press the **Up** or **Down Arrow** button to 200°F (93°C). Pressing and releasing the **Up** or **Down Arrow** buttons will increase the Set temperature by 1 degree. Pressing and holding the **Up** or **Down Arrow** button will increase Set temperature by 10 degrees. When the **Up** or **Down Arrow** button is released, a new temperature is Set. The Set temperature will appear in the **Digital Display** and the **Heat Indicator Light** will illuminate. Press the **Temperature Display** button for three seconds at any time to display the Actual air temperature inside of the cabinet.

To toggle between Set temperature and Actual inside air temperature:

Factory default is to display the Set temperature in the **Digital Display**.

To display the Actual air temperature inside of the cabinet:

Press and hold the **Temperature Display** button and the **Up Arrow** button for 5 seconds. The control will show ACT, then show the Actual temperature.

Repeat to toggle to the Set temperature.

Press the **Temperature Display** button at any time to display the alternate temperature.

- When the inside air temperature reaches the desired holding temperature, the **Heat Indicator Light** will go off.
- Load the cabinet with hot food only.**
The purpose of the holding cabinet is to maintain hot food at proper serving temperatures. Only hot food should be placed into the cabinet. Before loading the unit with food, use a food thermometer to make certain all food products are at an internal temperature range of 140°F to 160°F (60°C to 71°C). All food not within the proper temperature range should be heated before loading into the holding cabinet.
- Ensure the appliance door is securely closed, and using the **Up** or **Down Arrow** buttons, set the temperature to 160°F (71°C).

This will not necessarily be the final setting.

The proper temperature range for the food being held will depend on the type and quantity of product. Whether or not the vents should be open or closed will also depend on the type of food being held. When holding food for prolonged periods, it is advisable to periodically check the internal temperature of each item to assure maintenance of the proper temperature range. Reset the holding temperature accordingly.

To toggle between Fahrenheit/Celsius

Press the **Temperature Display** button at any time to display the alternate temperature.

The factory default is Fahrenheit. To change to Celsius:

- Press and hold the **Temperature Display** button and the **Down Arrow** for 5 seconds.
- The control will show °C for 3 seconds to verify selection and then show the temperature. (Set temperature or Actual temperature, whichever the user has selected) in °C.
- Repeat to toggle to Fahrenheit.

NOTE: With a power failure, factory test, etc., the control will retain the °C or °F setting selected by the user when power is restored.

Beeper Volume Settings

To adjust beeper volume settings, press and hold both the **Up** and **Down Arrow** buttons for 5 seconds. Display will show current setting, and beeper will emit the sound of that setting. Press the **Up** or **Down Arrow** buttons to cycle through the volume settings. Press the **Temperature Display** button to select the desired setting.

Display	Setting
bPr0	Off
bPr1	Low
bPr2	Medium
bPr3	High (factory default)

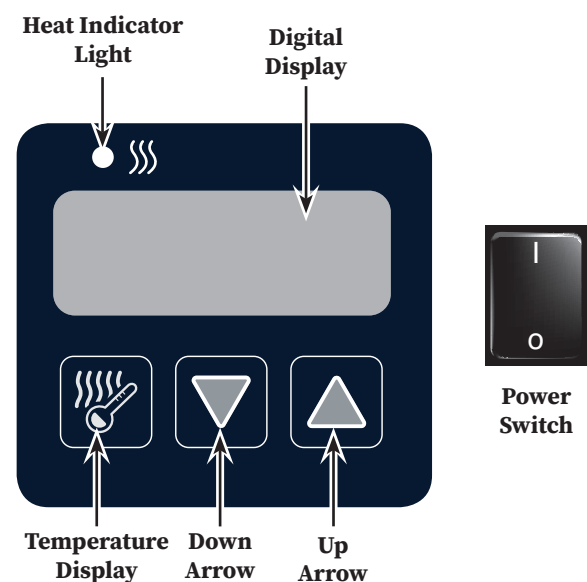

General Holding Guidelines

Chefs, cooks and other specialized food service personnel employ varied methods of cooking. Proper holding temperatures for a specific food product must be based on the moisture content of the product, product density, volume, and proper serving temperatures. Safe holding temperatures must also be correlated with palatability in determining the length of holding time for a specific product.

Halo Heat maintains the maximum amount of product moisture content without the addition of water, water vapor, or steam. Maintaining maximum natural product moisture preserves the natural flavor of the product and provides a more genuine taste. In addition to product moisture retention, the gentle properties of Halo Heat maintain a consistent temperature throughout the cabinet without the necessity of a heat distribution fan, thereby preventing further moisture loss due to evaporation or dehydration.

When product is removed from a high temperature cooking environment for immediate transfer into equipment with the lower temperature required for hot food holding, condensation can form on the outside of the product and on the inside of plastic containers used in self-service applications. Allowing the product to release the initial steam and heat produced by high temperature cooking can alleviate this condition. To preserve the safety and quality of freshly cooked foods however, a maximum of 1 to 2 minutes must be the only time period allowed for the initial heat to be released from the product.

This unit is equipped with a thermostat control between 60°F and 205°F (16°C and 96°C). If the unit is equipped with vents, close the vents for moist holding and open the vents for crisp holding. Use a metal-stemmed thermometer to measure the internal temperature of the product being held. Adjust the thermostat setting to achieve the best overall setting based on internal product temperature.

Holding Temperature Range		
Meat	Fahrenheit	Celsius
Beef Roast — Rare	130°F	54°C
Beef Roast — Med/Well Done	155°F	68°C
Beef Brisket	160°F-175°F	71°C-79°C
Corn Beef	160°F-175°F	71°C-79°C
Pastrami	160°F-175°F	71°C-79°C
Prime Rib — Rare	130°F	54°C
Steaks — Broiled/Fried	140°F-160°F	60°C-71°C
Ribs — Beef Or Pork	160°F	71°C
Veal	160°F-175°F	71°C-79°C
Ham	160°F-175°F	71°C-79°C
Pork	160°F-175°F	71°C-79°C
Lamb	160°F-175°F	71°C-79°C
Poultry		
Chicken — Fried/Baked	160°F-175°F	71°C-79°C
Duck	160°F-175°F	71°C-79°C
Turkey	160°F-175°F	71°C-79°C
General	160°F-175°F	71°C-79°C
Fish/Seafood		
Fish — Baked/Fried	160°F-175°F	71°C-79°C
Lobster	160°F-175°F	71°C-79°C
Shrimp — Fried	160°F-175°F	71°C-79°C
Baked Goods		
Breads/Rolls	120°F-140°F	49°C-60°C
Miscellaneous		
Casseroles	160°F-175°F	71°C-79°C
Dough — Proofing	80°F-100°F	27°C-38°C
Eggs — Fried	150°F-160°F	66°C-71°C
Frozen Entrees	160°F-175°F	71°C-79°C
Hors d'oeuvres	160°F-180°F	71°C-82°C
Pasta	160°F-180°F	71°C-82°C
Pizza	160°F-180°F	71°C-82°C
Potatoes	180°F	82°C
Plated Meals	140°F-165°F	60°C-74°C
Sauces	140°F-200°F	60°C-93°C
Soup	140°F-200°F	60°C-93°C
Vegetables	160°F-175°F	71°C-79°C
The holding temperatures listed are suggested guidelines only. All food holding should be based on internal product temperatures. Always follow local health (hygiene) regulations for all internal temperature requirements.		

Cleaning and Preventative Maintenance



It is important to guard against corrosion in the care of stainless steel surfaces. Harsh, corrosive, or inappropriate chemicals can completely destroy the protective surface layer of stainless steel. Abrasive pads, steel wool, or metal implements

will abrade surfaces causing damage to this protective coating and will eventually result in areas of corrosion. Even water, particularly hard water that contains high to moderate concentrations of chloride, will cause oxidation and pitting that result in rust and corrosion. In addition, many acidic foods spilled and left to remain on metal surfaces are contributing factors that will corrode surfaces.

Proper cleaning agents, materials, and methods are vital to maintaining the appearance and life of this appliance. Spilled foods should be removed and the area wiped as soon as possible but at the very least, a minimum of once per day. Always thoroughly rinse surfaces after using a cleaning agent and wipe standing water as quickly as possible after rinsing.

Use non-abrasive cleaning products designed for use on stainless steel surfaces. Cleaning agents must be chloride-free compounds and must not contain quaternary salts. Never use hydrochloric acid (muriatic acid) on stainless steel surfaces. Failure to observe this precaution will void the warranty. Always use the proper cleaning agent at the manufacturer's recommended strength. Contact your local cleaning supplier for product recommendations.

Cleaning Materials

Cleaning can usually be accomplished with the proper cleaning agent and a soft, clean cloth. When more aggressive methods are needed, use a non-abrasive scouring pad on difficult areas and make certain to scrub with the visible grain of surface metal to avoid surface scratches. Never use wire brushes, metal scouring pads, or scrapers to remove food residue. Failure to observe this precaution will void the warranty.

NOTICE



To protect stainless steel surfaces, completely avoid the use of abrasive cleaning compounds, chloride based cleaners, or cleaners containing quaternary salts. **Never** use hydrochloric acid (muriatic acid) on stainless steel. **Never** use wire brushes, metal scouring pads or scrapers.

! WARNING



To prevent **serious personal injury, death, or property damage:**

The appliance must be cleaned thoroughly to avoid deposits of grease and or food residue inside the appliance that may catch fire. If fat deposits and/or food waste inside the appliance ignite, shut down the appliance immediately and keep the appliance door closed to extinguish the fire. If further extinguishing is required, disconnect the appliance from the main power and call the fire department. Failure to clean the appliance properly voids the warranty and relieves Alto-Shaam of all liability.

Cleaning and Preventative Maintenance

WARNING



To prevent serious personal injury, death, or property damage:

Do not steam clean, hose down or flood the interior or exterior with water or liquid solution of any kind. **Do not** use water jet to clean. Failure to observe this precaution will void the warranty.

WARNING

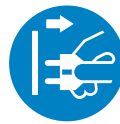

To prevent serious injury, death, or property damage, **always** disconnect the appliance from the power source before cleaning or servicing.

The cleanliness and appearance of this unit will contribute considerably to operating efficiency and savory, appetizing food. Good equipment that is kept clean works better and lasts longer.



Clean the unit thoroughly after each use

1. Disconnect appliance from power source, and let cool.
2. Remove, cover or wrap, and store unused products under refrigeration.
3. Remove all detachable items such as plate carriers, wire shelves, side racks, and any drip pans. Clean these items separately.
4. Clean interior with a damp cloth or sponge and any good commercial detergent at the recommended strength.
5. Spray heavily soiled areas with a water soluble degreaser and let stand for 10 minutes, then remove soil with a plastic scouring pad.



NOTICE: Avoid the use of abrasive cleaning compounds, chloride based cleaners, or cleaners containing quaternary salts. Never use hydrochloric acid (muriatic acid) on stainless steel.

6. Clean control panel, door vents, door handles, and door gaskets thoroughly since these areas harbor food debris.
7. Rinse surfaces by wiping with sponge and clean warm water.
8. Remove excess water with sponge and wipe dry with a clean cloth or air dry. Leave door open until interior is completely dry. Replace shelves.
9. Interior can be wiped with a sanitizing solution after cleaning and rinsing. This solution must be approved for use on stainless steel food contact surfaces.
10. To help maintain the protective film coating on polished stainless steel, clean the exterior of the cabinet with a cleaner recommended for stainless steel surfaces. Spray the cleaning agent on a clean cloth and wipe with the grain of the stainless steel.
11. Clean glass with a window cleaner.
12. Cart Cleaning --

Remove cart to a wash area and use any mild cleaning detergent and warm water. Handwipe all framing, slides, drip pan, and base. Thoroughly clean debris from the casters. A spray hose can be used for cart cleaning. Rinse detergent solution off with warm water. Wipe or spray with a sanitizing solution designed for use on metal and vinyl food contact surfaces. Allow cart to air dry.

Always follow appropriate state or local health (hygiene) regulations regarding all applicable cleaning and sanitation requirements for foodservice equipment.

Food Safety

Food flavor and aroma are usually so closely related that it is difficult, if not impossible, to separate them. There is also an important, inseparable relationship between cleanliness and food flavor. Cleanliness, operating efficiency, and appearance of equipment contribute considerably to savory, appetizing foods.

Most food imparts its own particular aroma and many foods also absorb existing odors. Unfortunately, during this absorption there is not a distinction between good and bad odors. The majority of objectionable flavors and odors troubling food service operations are caused by bacteria growth. Sourness, rancidity, mustiness, stale or other undesirable flavors are usually the result of germ activity.

The easiest way to ensure full, natural food flavor is through comprehensive cleanliness. This means good control of both visible soil (dirt) and invisible soil (germs). A thorough approach to sanitation will provide essential cleanliness. It will ensure an attractive appearance of equipment, along with maximum efficiency and utility. More importantly, a good sanitation program provides one of the key elements in the prevention of food-borne illnesses.

A comprehensive sanitation program should focus on the training of staff in basic sanitation procedures. This includes personal hygiene, proper handling of raw foods, cooking to a safe internal product temperature, and the routine monitoring of internal food temperatures from the time the food is received through the time the food is served.

A controlled holding environment for prepared foods is just one of the important factors involved in the prevention of food-borne illnesses. Temperature monitoring and control during receiving, storage, preparation, and the service of foods are of equal importance.

The most accurate method of measuring safe temperatures of both hot and cold foods is by internal product temperature. A thermometer is an effective tool for this purpose, and should be routinely used on all products that require holding at a specific temperature.

Internal Food Product Temperatures		
Hot Foods		
Danger Zone	40°F to 140°F	4°C to 60°C
Critical Zone	70°F to 120°F	21°C to 49°C
Safe Zone	140°F to 165°F	60°C to 74°C
Cold Foods		
Danger Zone	Above 40°F	Above 4°C
Safe Zone	36°F to 40°F	2°C to 4°C
Frozen Foods		
Danger Zone	Above 32°F	Above 0°C
Critical Zone	0°F to 32°F	-18°C to 0°C
Safe Zone	0°F or Below	-18°C or Below

Hazard Analysis (at) Critical Control Points (HACCP), is a quality control program of operating procedures to assure food integrity, quality, and safety. Taking steps necessary to augment food safety practices is both cost effective and relatively simple. Additional HACCP information is available by contacting:

Center for Food Safety and Applied Nutrition
 Food and Drug Administration
 Phone: 1-888-SAFEFOOD
www.foodsafety.gov

Electronic Control Accuracy

The electronic control is a precise instrument and is designed to offer trouble-free service. If you suspect the temperature inside the warming cabinet does not match the temperature indicated on the digital display, after stabilizing, follow the instructions listed below.

1. Check to make certain the unit voltage matches the power source. A power source less than that required to operate the unit will result in inaccurate temperatures.
2. Verify the temperature inside the holding compartment with a quality thermal indicator.
 - A. With the exception of the wire shelves, completely empty the holding compartment.
 - B. Make certain the holding cabinet sensor, located inside the holding compartment at the left side of the unit, is completely clean.
 - C. Suspend the thermal indicator in the center of the holding compartment.
 - D. Allow the temperature set on the electronic thermostat to stabilize for a minimum of one hour before comparing the digital display with the reading on the thermal indicator.

Do not open the cabinet door(s) during the temperature stabilization period.

If the reading on the thermal indicator does not match the digital display, there may be a problem with the air sensor. See troubleshooting guide in this manual, or call the factory service department for advice.

Special Features**Heat Recovery**

The patented SureTemp™ heat recovery system in this unit will immediately compensate for any loss of heat when the door is opened. In order to maintain a more consistent cavity temperature, the control will automatically apply heat to the unit's interior while the door is open and for a short time after the door is closed. If the door remains open for more than three minutes, the solid state electronic control will sound three rapid beeps every ten seconds until the door is closed.

NOTICE

If the appliance has been unplugged for an extended period of time, the Real Time Clock may require recharging. Turn main breaker to the unit off for 10 seconds and then restore power. For more information, see Error Code E-60 in the Troubleshooting section of this manual.

How to verify sensor integrity

Place the sensor in ice water. Test with an ohmmeter set to the ohm scale.

Air sensor	1000 ohms \pm 20
------------	--------------------

If the reading is more than \pm 20 ohms, replace sensor.

Always check the circuit breaker is turned "On" and your unit is receiving power before calling your Authorized Alto-Shaam Service Agent.

NOTICE

This section is provided for the assistance of qualified and trained service technicians only and is not intended for use by untrained or unauthorized service personnel. Do not attempt to repair or service the oven beyond this point. Contact Alto-Shaam for the nearest authorized service agent. Repairs made by any other service agents without prior authorization by Alto-Shaam will void the warranty.

**! DANGER**

To prevent serious injury, death, or property damage, **always** lock-out or post breaker panel until service work has been completed.

Troubleshooting

Code	Description	Possible Causes
E-10	Cavity air sensor shorted	Cavity air sensor reading < 5°F (-15°C). Verify sensor integrity.
E-11	Cavity air sensor open	Cavity air sensor reading > 517°F (269°C). Verify sensor integrity.
E-20	Product probe is shorted <i>Oven will cook in time only</i>	Product probe reading < 5°F (-15°C). Verify sensor integrity.
E-21	Product probe is open <i>Oven will cook in time only</i>	Product Probe reading > 517°F (269°C). Verify sensor integrity.
E-30	Under temperature	Unit has been more than 25°F (14°C) below set point for longer than 90 minutes.
E-31	Over temperature	Unit has been more than 60°F (33°C) above the maximum set-point for longer than 3 minutes. Holding Cabinets with this error code are more than 145°F (81°C) above the maximum set-point.
E-32	Safety switch open (Aux hi-limit switch)	Contact factory.
E-38	Internal software error	Contact factory.
E-39	Sensor error	Contact factory.
E-50	Temp. measurement error	Contact factory.
E-51	Temp. measurement error	Contact factory.
E-60	Real time clock error	Data set to factory default. Ensure that date and time are correct if applicable.
E-61	Real time clock error	Contact factory.
E-64	Clock is not oscillating	Contact factory.
E-70	Configuration connector error (DIP switch)	Refer to the electrical schematic and ensure dip switches on the control match the settings called out on the schematic. If the dip switch settings are correct, according to the schematic, replace the control.
E-78	Voltage low	Voltage below 90 VAC on a 125 VAC unit, or below 190 VAC on a 208-240 VAC unit. Adjust DC voltage. See "How to Adjust DC Voltage" in this manual.
E-79	Voltage high	Voltage over 135 VAC on a 125 VAC unit, or over 250 VAC on a 208-240 VAC unit. Adjust DC voltage. See "How to Adjust DC Voltage" in this manual.
E-80	EEPROM Error	Ensure that all temperatures and times are properly set. Contact factory if problem persists.
E-81	EEPROM Error	Contact factory.
E-82	EEPROM Error	Contact factory.
E-83	EEPROM Error	Contact factory.
E-85	EEPROM Error	All timers, if previously on, are now off. Possible bad EEPROM.
E-86	EEPROM Error	Stored HACCP memory corrupted. HACCP Address reset to 1. Possible bad EEPROM. Contact factory if problem persists.
E-87	EEPROM Error	Stored offsets corrupted. Offsets reset to 0. Control may need a recalibration. Possible bad EEPROM. Contact factory if problem persists.
E-88	EEPROM Error	All timer set-points are reset to 1 minute. Timers, if previously on, are now off. Possible bad EEPROM.
E-90	Button stuck	A button has been held down for > 60 seconds. Adjust control. Error will reset when the problem has been resolved.
E-91	Input failure	Contact factory.
E-dS	Datakey error	Datakey digital signature incompatible. Cycle power, and install compatible Datakey if error persists.
E-dT	Datakey error	Datakey incompatible with control. Install compatible Datakey.
E-dU	Datakey unplugged	Install Datakey and cycle power to control to clear error.
dLto	Datalogger has timed out	Cycle power. Contact factory if error persists.
dLSD	Micro SD card not plugged in	Plug in SD card and cycle power. Contact factory if error persists.

NOTE: If in doubt, always cycle the power to the control and contact factory if the problem persists.

Service View - 20-20MW

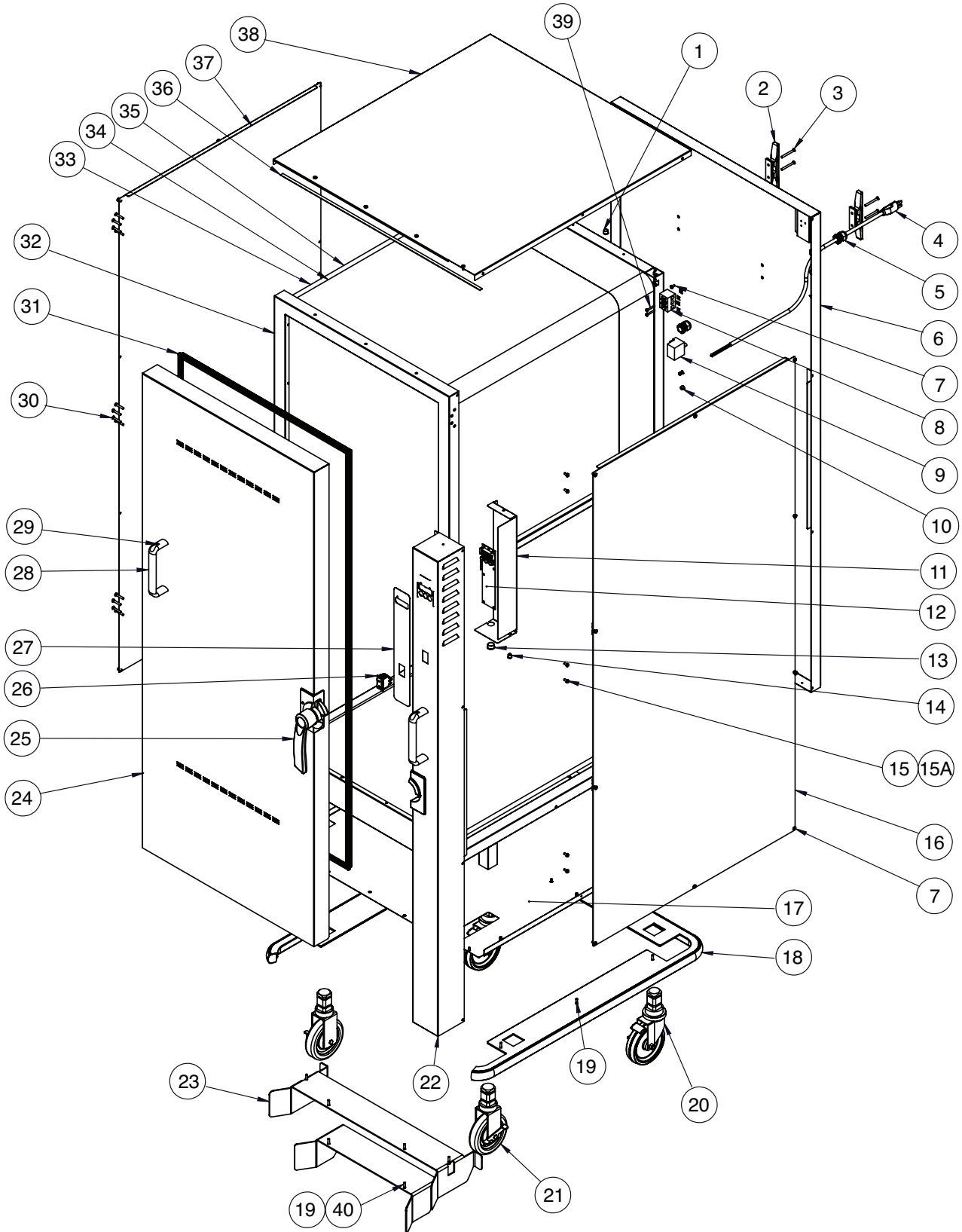

Part numbers and drawings are subject to change without notice.

Service

Service Parts List - 20-20MW

Item	Description	Part No.	Qty	Item	Description	Part No.	Qty
1	Bushing, 1/2" Hole	BU-3006	2	21	Caster, 5" Rigid	CS-35290	2
2	Hanger 6-1/2" Rope Cleat, 7/16 Blk	E2097HR	2	22	Control Panel Left Hand	5016977	1
3	Screw, M5 x 0.8 x 50mm Flat	SC-35259	4		Control Panel Right Hand	5017220	1
4	Cordset 208-240V, NEMA 6-15P	CD-3551	1	23	Bracket, Trolley Guide 20-20	1015573	1
	230V, CEE 7/7	CD-3922	1		Bracket, Trolley Guide 20-10	1015611	1
	230V, BS 1363	CD-33925	1	24	Door Assembly Left Hand	5016976	1
	230V, CH2-16P	CD-3623	1		Door Assembly Right Hand	5017221	1
	230V, AS/NZS 3112	CD-38149	1	25	Handle, Door Left Hand	HD-26967	1
5	Bushing, Straight, Strain Relief	BU-3964	1		Handle, Door Right Hand	HD-26966	1
6	Back Panel, Spot Left Hand	5016982	1	26	Switch, Rocker, 125-277V, 20A	SW-34769	1
	Back Panel, Spot Right Hand	5017219	1		Switch Cover (230V only)	CV-38297	1
7	Screw, M5 x 0.8 x 10mm Pan	SC-22766	29	27	Panel Overlay	PE-36464	1
8	T-Block	BK-3019	1	28	Transport Handle	HD-22257	2
9	Thermostat, Hi-Limit	TT-33417	1	29	Screw, M6 x 1.0 x 30mm Flat	SC-27284	5
10	Plug, 3/8" Hole	PG-25574	1	30	Screw, M6 x 1 x 25mm Flat	SC-27274	21
11	Baffle, Heat Control Left Hand	1015373	1	31	Door Gasket	GS-36417	1
	Baffle, Heat Control Right Hand	1015598	1	32	Trim, Front	1015354	1
12	Control	CC-36403	1	33	Tube Insulation	5016988	1
13	Bushing, 3/4" White Snap	BU-3008	1	34	Insulation, TRS-30, Fiberglass, 176	IN-22364	2
14	Bushing, 3/8" Black Hole	BU-3419	1	35	Element, 1500W, T-Shape Foil	EL-36365	2
15	Stud, M5 x 30mm, S/S	ST-38211	6	36	Gasket, Foam 31.5" Length	GS-23622	1
15A	Nut, M5, KEPS	NU-36234	6	37	Panel, Control Side Access	1015370	1
16	Panel, Control Side Access	5017222	1	38	Cover, Top Left Hand	1015356	1
17	Cover, Bottom Left Hand	1015357	1		Cover, Top Right Hand	1015600	1
	Cover, Bottom Right Hand	1015599	1	39	Screw M4 x 0.7 x 30 Pan PHH SST A2 MS	SC-29276	2
18	Bumper Base Assembly	5016986	1	40	Washer, M6, Flat	WS-22297	4
19	Screw, M5 x 0.8 x 20mm Hex	SC-24391	13	41	Sensor (Not shown)	SN-38111	1
20	Caster, 5" Swivel w/Brake	CS-24875	2				

WARNING

To prevent serious injury, death, or property damage, **always** disconnect the appliance from the power source before cleaning or servicing.

DANGER

To prevent serious injury, death, or property damage, **always** lock-out or post breaker panel until service work has been completed.

Service View - 20-20W

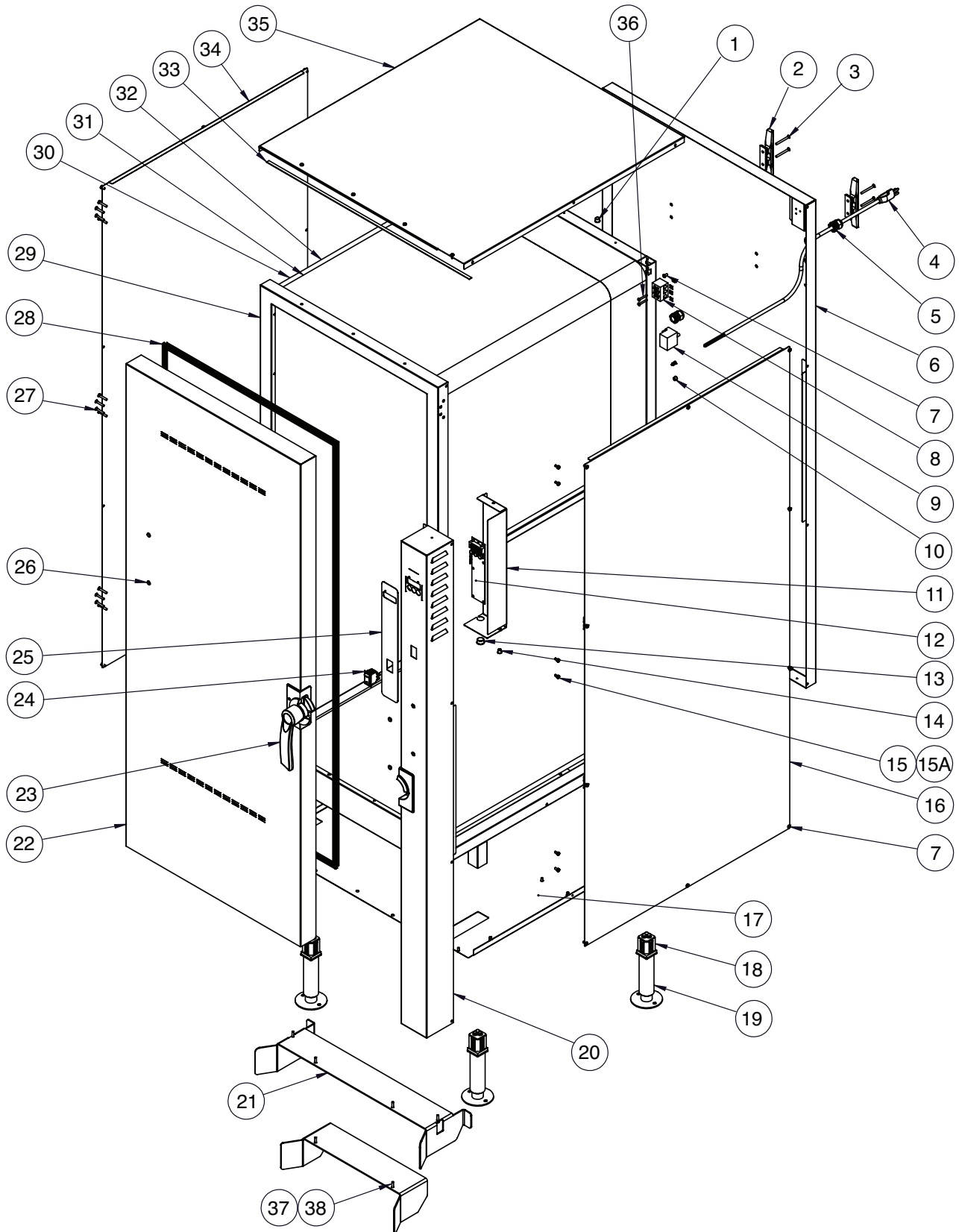

Part numbers and drawings are subject to change without notice.

Service

Service Parts List - 20-20W

Item	Description	Part No.	Qty	Item	Description	Part No.	Qty
1	Bushing, 1/2" Hole	BU-3006	2	20	Control Panel Left Hand	5016977	1
2	Hanger 6-1/2" Rope Cleat, 7/16 Blk Nylon	E2097HR	2		Right Hand	5017220	1
3	Screw, M5 x 0.8 x 50mm Flat	SC-35259	4	21	Bracket, Trolley Guide 20-20	1015573	1
4	Cordset 208-240V, Nema 6-15P	CD-3551	1		20-10	1015611	1
	230V, Cee 7/7	CD-3922	1	22	Door Assembly Left Hand	5016976	1
	230V, Bs 1363	CD-33925	1		Right Hand	5017221	1
	230V, Ch2-16P	CD-3623	1	23	Handle, Door Left Hand	HD-26967	1
	230V, As/Nzs 3112	CD-38149	1		Right Hand	HD-26966	1
5	Bushing, Straight, Strain Relief	BU-3964	1	24	Switch, Rocker, 125-277V, 20A	SW-34769	1
6	Back Panel, Spot Left Hand	5016982	1		Switch Cover (230V only)	CV-38297	1
	Right Hand	5017219	1	25	Panel Overlay	PE-36464	1
7	Screw, M5 x 0.8 x 10mm Pan	SC-22766	29	26	Plug, Sheet Metal, Finished Head	PG-38218	4
8	T-Block	BK-3019	1	27	Screw, M6 x 1 x 25mm Flat	SC-27274	21
9	Thermostat, Hi-Limit	TT-33417	1	28	Door Gasket	GS-36417	1
10	Plug, 3/8" Hole	PG-25574	1	29	Trim, Front	1015354	1
11	Baffle, Heat Control Left Hand	1015373	1	30	Tube Insulation	5016988	1
	Right Hand	1015598	1	31	Insulation, TRS-30, Fiberglass, 176	IN-22364	2
12	Control	CC-36403	1	32	Element, 1500W, T-Shape Foil	EL-36365	2
13	Bushing, 3/4" White Snap	BU-3008	1	33	Gasket, Foam 31.5" Length	GS-23622	1
14	Bushing, 3/8" Black Hole	BU-3419	1	34	Panel, Control Side Access	1015370	1
15	Stud, M5 x 30mm, S/S	ST-38211	6	35	Cover, Top Left Hand	1015356	1
15A	Nut, M5, KEPS	NU-36234	6		Right Hand	1015600	1
16	Panel, Control Side Access	5017222	1	36	Screw M4 x 0.7 x 30 Pan PHH SST A2 MS	SC-29276	2
17	Cover, Bottom Left Hand	1015357	1	37	Screw, M5 x 0.8 x 20mm Hex	SC-24391	13
	Right Hand	1015599	1	38	Washer, M6, Flat	WS-22297	4
18	Adapter, 1.5 Sq Tube	LG-37094	4	39	Sensor (Not Shown)	SN-38111	1
19	6" Leg W/ Adjustable Flanged Foot	LG-23067	4				

WARNING

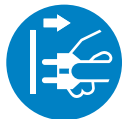

To prevent serious injury, death, or property damage, **always** disconnect the appliance from the power source before cleaning or servicing.

DANGER



To prevent serious injury, death, or property damage, **always** lock-out or post breaker panel until service work has been completed.

Pan Cart (optional)

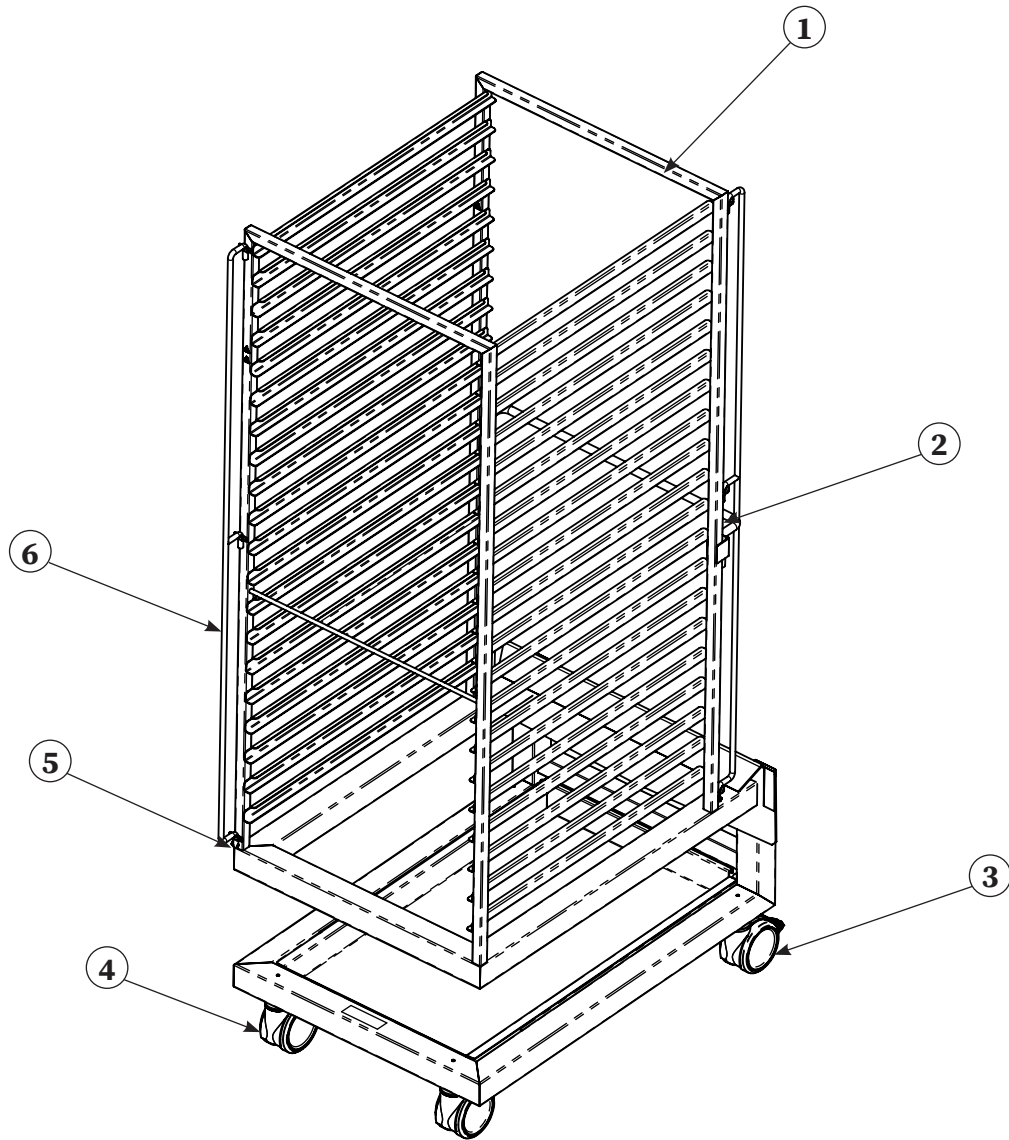

Item	Description	Part No.	Qty
1	Trolley Rack Assembly	5026385	2
2	Trolley Handle	5017961	1
3	Caster, Swivel, with Brake	CS-36219	2
4	Caster, Swivel, no Brake	CS-36218	2
5	Screw, M4 x 0.7 x 10mm Hex	SC-23664	2
6	Rod, Trolley Lock	1014124	2

Part numbers and drawings are subject to change without notice.

Wiring Diagram

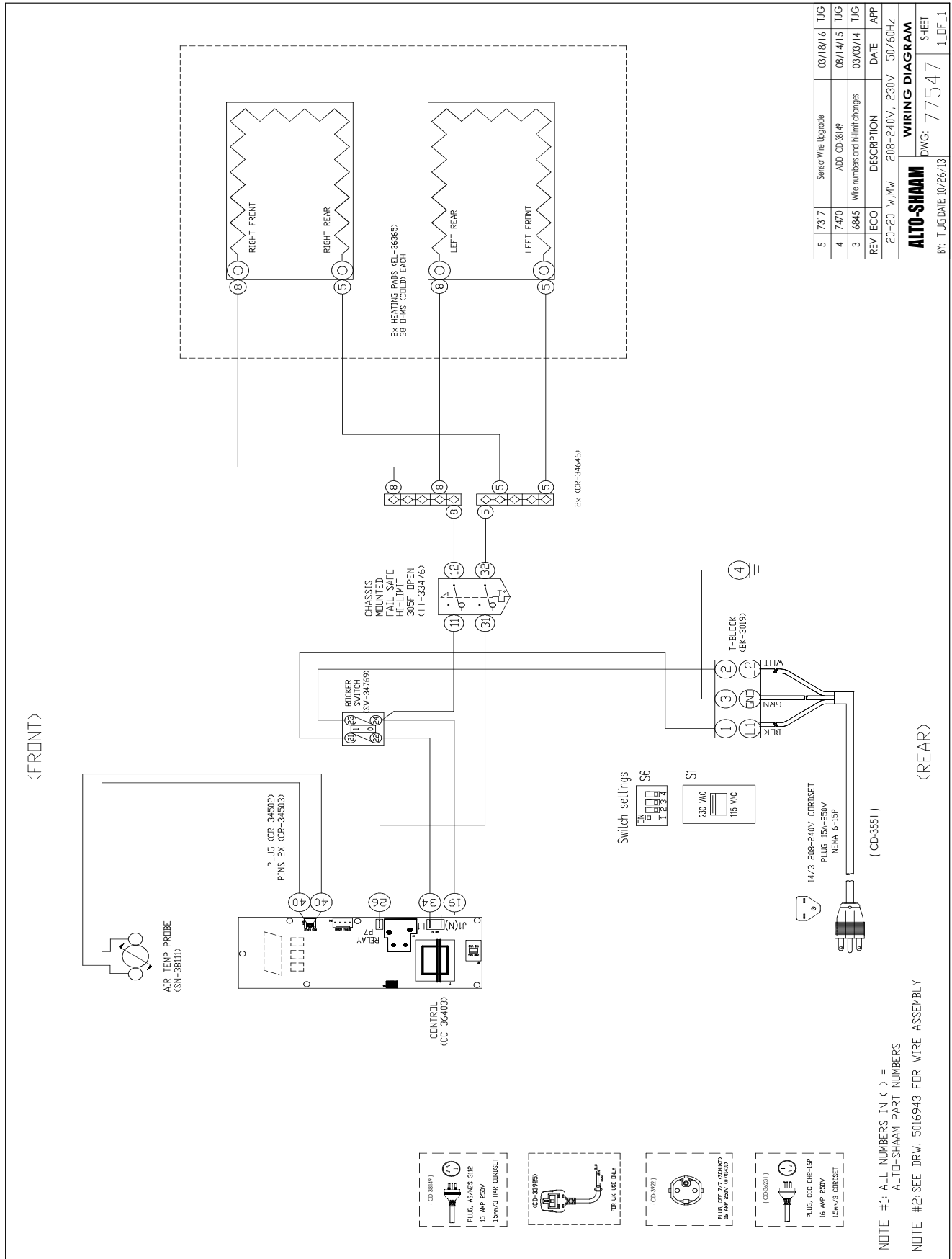

5	7317	Senior Wire Upgrade	03/18/16	TJG
4	7470	ADD CD-38149	08/14/15	TJG
3	6845	Wire numbers and hi-limit change	03/03/14	TJG
REV	ECO	DESCRIPTION	DATE	APP
	20-20	V, MW	208-240V, 230V	50/60HZ
ALTO-SHAAM			WIRING DIAGRAM	
DWG: 77547			SHEET	
BY: T.JG/DAE:10/26/13			1 OF 1	

NOTE #1: ALL NUMBERS IN () = ALTO-SHAAM PART NUMBERS
 NOTE #2: SEE DRW. 5016943 FOR WIRE ASSEMBLY

Alto-Shaam, Inc. warrants to the original purchaser only that any original part that is found to be defective in material or workmanship will, at Alto-Shaam's option, subject to provisions hereinafter stated, be replaced with a new or rebuilt part.

The original parts warranty period is as follows:

For the refrigeration compressor on Alto-Shaam Quickchillers™, five (5) years from the date of installation of appliance.

For the heating element on Halo Heat® cooking and holding ovens, as long as the original purchaser owns the oven. This excludes holding only equipment.

For all other original parts, one (1) year from the date of installation of appliance or fifteen (15) months from the shipping date, whichever occurs first.

The labor warranty period is one (1) year from the date of installation or fifteen (15) months from the shipping date, whichever occurs first.

Alto-Shaam will bear normal labor charges performed during standard business hours, excluding overtime, holiday rates or any additional fees.

To be valid, a warranty claim must be asserted during the applicable warranty period. This warranty is not transferable.

This warranty does not apply to:

1. Calibration.
2. Replacement of light bulbs, door gaskets, and/or the replacement of glass due to damage of any kind.
3. Equipment damage caused by accident, shipping, improper installation or alteration.
4. Equipment used under conditions of abuse, misuse, carelessness or abnormal conditions, including but not limited to, equipment subjected to harsh or inappropriate chemicals, including but not limited to, compounds containing chloride or quaternary salts, poor water quality, or equipment with missing or altered serial numbers.
5. Damage incurred as a direct result of poor water quality, inadequate maintenance of steam generators and/or surfaces affected by water quality. Water quality and required maintenance of steam generating equipment is the responsibility of the owner/operator.
6. Damage caused by use of any cleaning agent other than Alto-Shaam's Combitherm® Cleaner, including but not limited to damage due to chlorine or other harmful chemicals. **Use of Alto-Shaam's Combitherm® Cleaner on Combitherm® ovens is highly recommended.**
7. Any losses or damage resulting from malfunction, including loss of product, food product, revenue, or consequential or incidental damages of any kind.
8. Equipment modified in any manner from original model, substitution of parts other than factory authorized parts, removal of any parts including legs, or addition of any parts.

This warranty is exclusive and is in lieu of all other warranties, express or implied, including the implied warranties of merchantability and fitness for a particular purpose. In no event shall Alto-Shaam be liable for loss of use, loss of revenue or profit, or loss of product, or for any indirect, special, incidental, or consequential damages. No person except an officer of Alto-Shaam, Inc. is authorized to modify this warranty or to incur on behalf of Alto-Shaam any other obligation or liability in connection with Alto-Shaam equipment.

Effective November 1, 2012