

# Cook & Hold Oven

## Model 1750-TH

Original Cook & Hold Ovens produce better food quality and higher yields with built-in savings.

Gentle, radiant Halo Heat® technology evenly surrounds food without the use of extremely hot elements, added humidity or fans. This controlled, uniform heat maintains precise temperatures throughout the cooking and holding process—improving food quality and extending hold times.

Cook by time or probe with Simple or Deluxe controls. Probes sense internal product temperature and automatically convert the oven from cook mode to hold mode once set parameters have been reached.

Labor-free, overnight cooking and effortless operation reduces labor costs and increases productivity.

Place anywhere with a ventless, waterless design. Lower costs with energy efficient operation and no water hookups or traditional kitchen hood required. All Alto-Shaam Cook & Hold Ovens are EPA 202 Certified ventless.

Advanced controls – designed intentionally simple – feature an intuitive, user-friendly interface and programmable recipes to ensure consistency with each cook.

ChefLinc™, cloud-based remote oven management software, streamlines processes and maximizes profits with data-driven insights [Deluxe model only].

ISO 9001:2015-certified

### Standard Features

- Casters (two [2] rigid, two [2] swivel with brake)
- Single-point, straight removable probe
- Drip tray and drip pan with drain
- Programmable, touchscreen control on Deluxe model
- HACCP data collection on Deluxe model
- Programmable control on Simple model
- Easy recipe upload/download via USB port
- SureTemp™ heat recovery on Deluxe model
- Two [2] stainless steel side racks with ten [10] pan positions spaced 1-3/8" [35mm] on centers
- Removable exterior drip tray



**CAPACITY**  
per Cavity

**10** Full-size pans — 20" x 12" x 2-1/2" per cavity, on wire shelves only

GN 1/1 — 530mm x 325mm x 65mm

**20** Half-size pans — 10" x 12" x 2-1/2" per cavity, on wire shelves only

GN 1/2 — 265mm x 325mm x 65mm

Maximum weight per cavity: 100 lbs. [45 kg]

Maximum volume cavity: 75 quarts [71 liters]

Eight [8] shelves included [4 per cavity].



ALTO-SHAAM



Shown with Deluxe control



Shown with Simple control

**1750-TH**

### Configurations (select one each)

#### Models

- Simple
  - HACCP option
- Deluxe
  - Ethernet option [5032090]

#### Door Choice

- Right hinged, solid door, standard
- Right hinged, window door
- Left hinged, solid door
- Left hinged, window door

#### Electrical

- 208-240V, 1Ph

#### Casters and Legs

- 3-1/2" [89mm] casters, two [2] rigid two [2] swivel with brake, standard [5027133]
- 5" [127mm] casters, two [2] rigid two [2] swivel with brake, option, [5027112]
- 6" [152mm] legs, set of four [4] [5032092]
- 6" [152mm] seismic legs, set of four [4] [5032093]

### Optional Accessories (select all that apply)

#### Bumper and Handles

- Full perimeter bumper
- Push/Pull handle kit

#### Additional Probes

- Sous vide probe [PR-36576]
- T-handle probe, up to six [6] with Deluxe per cavity [PR-46998]
- Straight probe, up to six [6] with Deluxe per cavity [qty two [2] included with oven] [PR-46999]

#### Drip Pans, Shelves, Holders

- Drip pan with drain [5027713]
- Drip pan, without drain [1034370]
- Increased capacity exterior drip pan [5030664]
- Shelf, stainless steel [SH-2324]
- Carving holder, prime rib [HL-2635]
- Carving holder, steamship [cafeteria round] [4459]

#### Cleaners

- Alto-Shaam, non-caustic cleaner one [1] 32-ounce bottle [CE-46828]
- Alto-Shaam, non-caustic cleaner six [6] 32-ounce bottles [CE-46829]

#### Accessories, misc.

- Door lock with key [5028755]

# Cook & Hold Oven

## Model 1750-TH



**DIMENSIONS**

OVERALL HEIGHT: 750-TH		
Accessory	in	mm
5" caster	58-1/16"	1474
3-1/2" caster	57"	1448
6" leg (min)	55-15/16"	1420
6" leg (max)	58-3/16"	1477
6" seismic leg (min)	56-7/8"	1444
6" seismic leg (max)	59-5/16"	1506

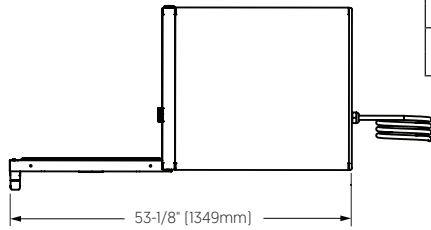

Shown with Simple control and 3-1/2" casters

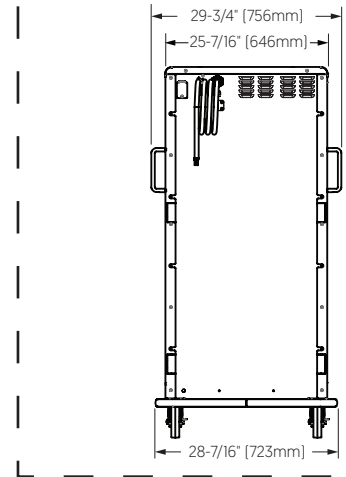
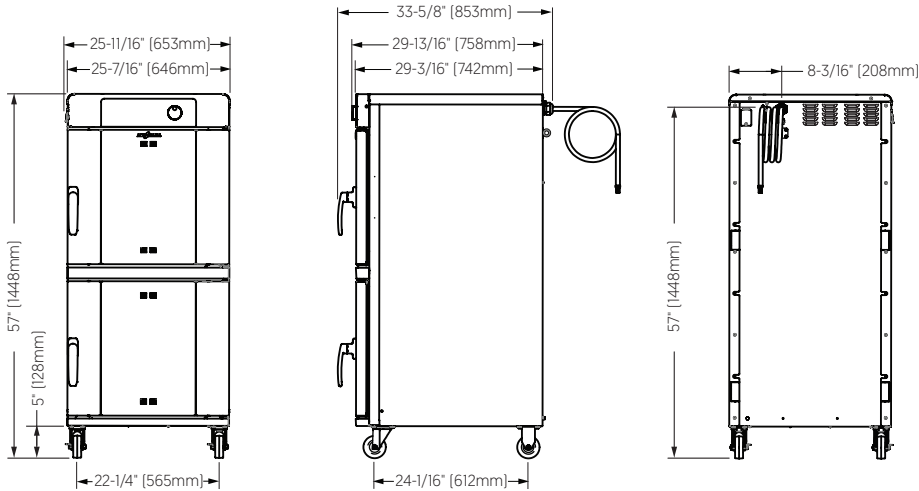
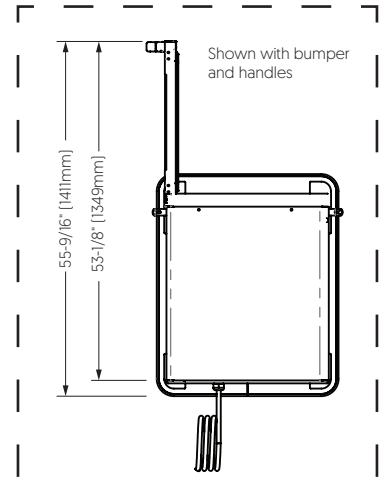

Interior (H x W x D) Per Cavity	Net Weight	Ship Dimensions (L x W x H)	Ship Weight
20-1/16" x 22" x 26-1/2" (510mm x 559mm x 673mm)	440 lbs. (200 kg)	39" x 39" x 79" (991mm x 991mm x 2007mm)	530 lbs. (240 kg)



**CLEARANCE**

- Top:..... 2" (51mm)
- Left:..... 2" (51mm)
- Right:..... 2" (51mm)
- Back:..... 3" (76mm)



**CHECK FIRST**

The oven must be installed level.  
The oven must not be installed in any area where it may be affected by steam, grease, dripping water, high temperatures, or any other severely adverse conditions.

# Cook & Hold Oven

## Model 1750-TH



### Heat of rejection

1750-TH	Heat Gain qs, BTU/hr	Heat Gain qs, kW
	1,825	0.53



### Cooking temperature range:

200°F–325°F [94°C–163°C]

### Holding temperature range:

85°F–205°F [29°C–96°C]



1750-TH	V	Ph	Hz	Awg	IEC	A	Breaker (A)	kW	Plug Configuration	Certification
208–240V**	208	1	50/60	8	—	29	30 UL   50 CSA	6.3	Alto-Shaam offers a number of readily available cord and plug configurations. Contact factory for options.	
	240	1	50/60	8	—	35	50	8.3		
230V	230	1	50/60	8	—	33	63	7.6		
	230	1	50/60	8	—	22	32	5.1*		
380–415V	380	3	50/60	10	2.5	18	32	7.0		
	415	3	50/60	10	2.5	20	32	8.2		

Electrical connections must meet all applicable federal, state, and local codes.

\*Reduced wattage configuration.

\*\*Dedicated circuit required.

## CONTACT US

W164 N9221 Water Street | Menomonee Falls, Wisconsin 53051 | U.S.A.  
 Phone: 262.251.3800 | 800.558.8744 U.S.A./Canada | Fax: 262.251.7067 | [alto-shaam.com](http://alto-shaam.com)